

Mechanical Services Shops Department



Abu Ali Water Injection Shipper Pump Failures

By: Adeeb AL-Safrani

March 8, 2007

Outline

- Process Overview
- Repair History
- Findings and Repairs
- Failure Analysis
- Recommendations

Process Overview

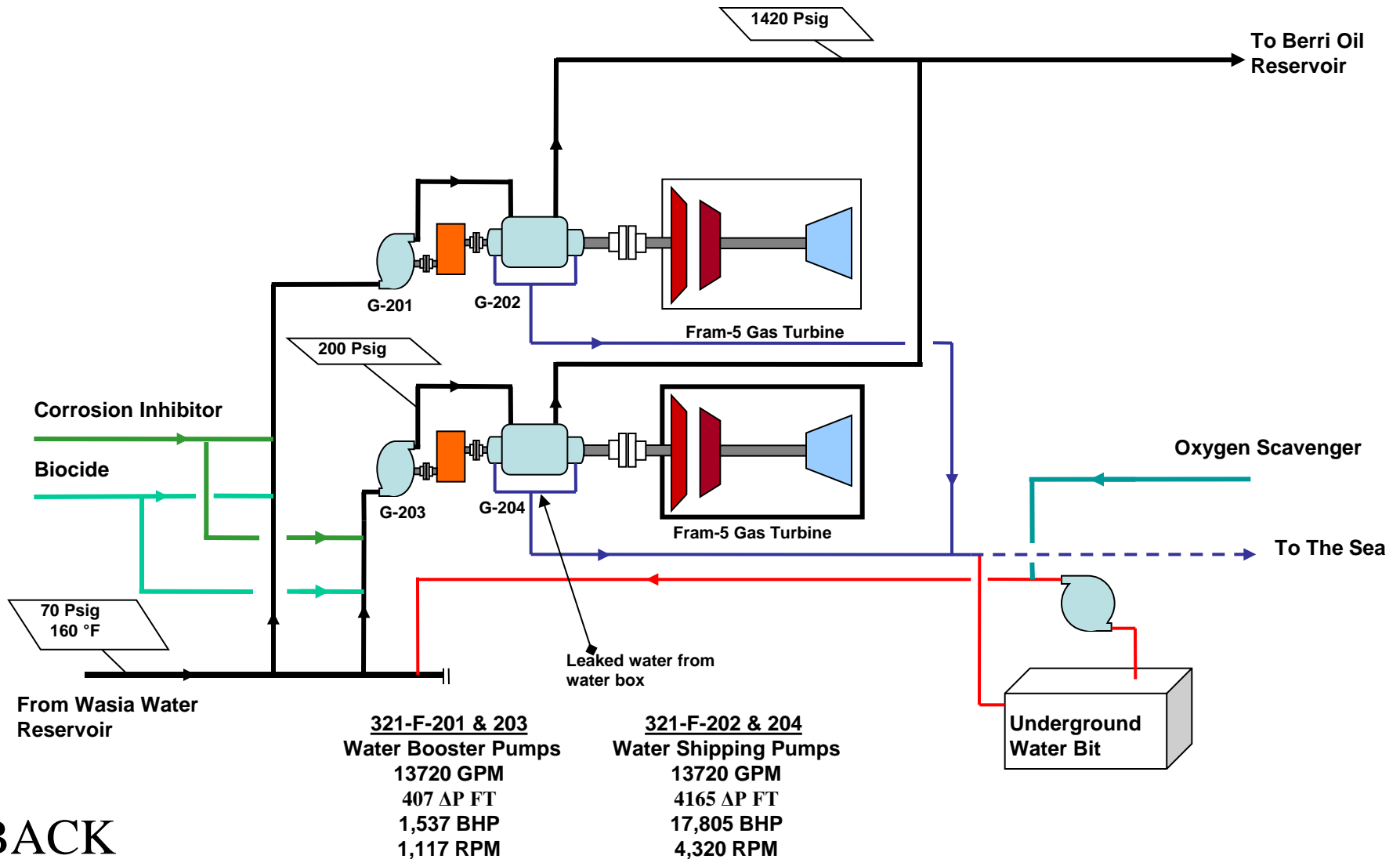

BACK

Historical Repair Background

- Three Shipper Pumps installed in Abu Ali WIP in 1973
- Three Pumps repaired in 1990, 1994 and 1997.
- One Pump was repaired in 1999
- Two Pumps were repaired in 2000 and 2003
- Two Pumps were returned back for repair in 2004 and 2005

Findings & Repairs

Problem: Pump Seized

Findings:

- Pitting Corrosion on the pump casing and pump shaft
- Cavitation and erosion on the 1st stage impeller
- Water boxes and shaft sleeves were completely damaged

Repairs:

- Pump casing was coated by Inconel 625 coating
- 1st stage impeller was replaced to 316 SS
- Pump shaft was fabricated out from CS 4340
- Water boxes and shaft sleeves were replaced

Failure Analysis

1- Cavitation

2- Pitting Corrosion

1- Cavitation

Definition:

It is the formation of vapor bubbles in the low pressure zones of the impeller blades if the local static pressure becomes lower than the fluid vapor pressure. Then the vapor bubbles move to higher pressure zones of the impeller and collapse producing high pressure pulses.

Result:

- > Pump head and capacity will be decreased
- > Pump efficiency will be dropped
- > Impeller metal damage
- > Pump noise and vibration will be increased

Cause:

- > $NPSH_{cavitation\ inception} < NPSH_{available}$

G-202 Rating Conditions:

- Pump Rating Speed: 4320 RPM
- Rating Capacity : 13720 GPM
- Normal Suction Pressure: 176 PSIA
- NPSHr: 170 FT
- Fluid : raw water at 155 deg F
- Vapor Pressure: 4.4 PSIA
- Specific Gravity: 0.98

Net Positive Suction Head

- It is a measure to prevent liquid vaporization
- It has several values:
 - > Net Positive Suction Head at Cavitation Inception (NPSHinc)
 - > Net Positive Suction Head for Impeller Life (e.g. NPSH-40,000 Hours)
 - > Net Positive Suction Head Required for 3% Head Drop (NPSHr)
 - > Net Positive Suction Head Available (NPSHa)
- $$\text{NPSHa} = 2.31 * (P_s - P_v) / SG$$
$$= 2.31 * (176 - 4.4) / 0.98 = 404 \text{ FT}$$
- $\text{NPSHr} = 170 \text{ FT}$

@ Rated Point (Pump shop test)
- $\text{NPSHa} / \text{NPSHr} = 404 / 170 = 2.38$

G-202 Pump Characteristics at Rated Conditions

- Speed: 4320 RPM
- Rated Capacity : 13720 GPM = 0.83 X Q_{bep} (D-duty)
- Capacity Q @ BEP based on Impeller duty diameter: 16500 GPM
- Impeller duty diameter (D-duty) : 19.44 “ (trimmed)
- Rated Head : 4165 FT (two stages)
- Head per stage @BEP (D-duty) : 1900 FT
- Specific Speed @BEP (D-duty) : 1930

G-202 Pump Design Conditions

- Rated Speed: 4320 RPM
- Impeller design diameter : 21.5 " Max
- Capacity Q @ BEP based on Design Impeller Diameter: 18800 GPM
- NPSHr @ BEP based on Max Impeller Diameter: 260 FT
- Impeller eye diameter : 12.625"

Suction Specific Speed

- It is considered in the normal practice as an index for determining whether a pump impeller will experience suction recirculation if operates at flow rate below the bep capacity .
- It is a conventional hydraulic parameter to compare different pump designs with reference to “ suction performance “ expressed with NPSHr (i.e. Head drop caused by cavitation).
- Pump impellers with high Nss values are in general prone to present the suction recirculation onset capacity close to the design capacity . Also these impellers have a large eye diameter and are more susceptible to high cavitation damage depending on : Q_{oper} / Q_{bep} , $NPSHA / NPSH_{inc}$, $NPSHA / NPSH_r$, and speed (peripheral velocity at impeller eye) .
- Nss values above 10000 are commonly considered “ critical “ , while values below 8000 are more “ safe “ for wide operating range .
- Impeller damage caused by suction recirculation – vortex cavitation is on the blade inlet pressure side (not visible side) near blade midspan .

Suction Specific Speed (Nss) (cont.d)

- $N_{ss} = [N * (Q/2) ^ { 1/2 }] / [(NPSHr) ^ { 3/4 }]$
($Q=Q/2$ For double suction impeller)
- $N_{ss} = [4320 * (18800/2) ^ { 1/2 }] / [(260) ^ { 3/4 }] = 6500$

The $N_{ss} = 6500$ is a low value even lower than 8000 . This suggests that the onset of suction recirculation and associated problems (high vibrations , possible damage on the impeller blade pressure side would occur at operating capacity significantly lower than the design capacity) .

Pump Selection and Key Operating Conditions

- Actual flow rate Q_a for Pump G-202 range between 10000 to 13000 GPM
- Rated (original) flow rate Q_r for Pump G-202 : 13720 GPM
- Flow rate @ BEP Q_{bep} for Pump G-202 : 18800 GPM
- Shockless flow rate Q_{si} for Pump G-202 : $Q_{si} = 1.05 * Q_{bep} = 19750$ GPM
- $Q_r = 0.69 Q_{si}$
- $Q_a = 0.51$ to $0.66 Q_{si}$
- $Q_r = 0.73 Q_{bep}$
- $Q_a = 0.53$ to $0.69 Q_{bep}$
- Impeller eye peripheral velocity : 238 FT/S

Pump Operational Problems : Impeller Damage

- Surface aspect in the damaged zone : typical cavitation pitting
- Location : blade suction side (visible side) . No damage observed on the blade pressure side (backside)
- Cavitation mode : “ Blade sheet cavitation “ attached to the vane .



NPSHR 40,000 hour Life - Vlaming's Method

ASME, Pumping Machinery Symposium, 1989

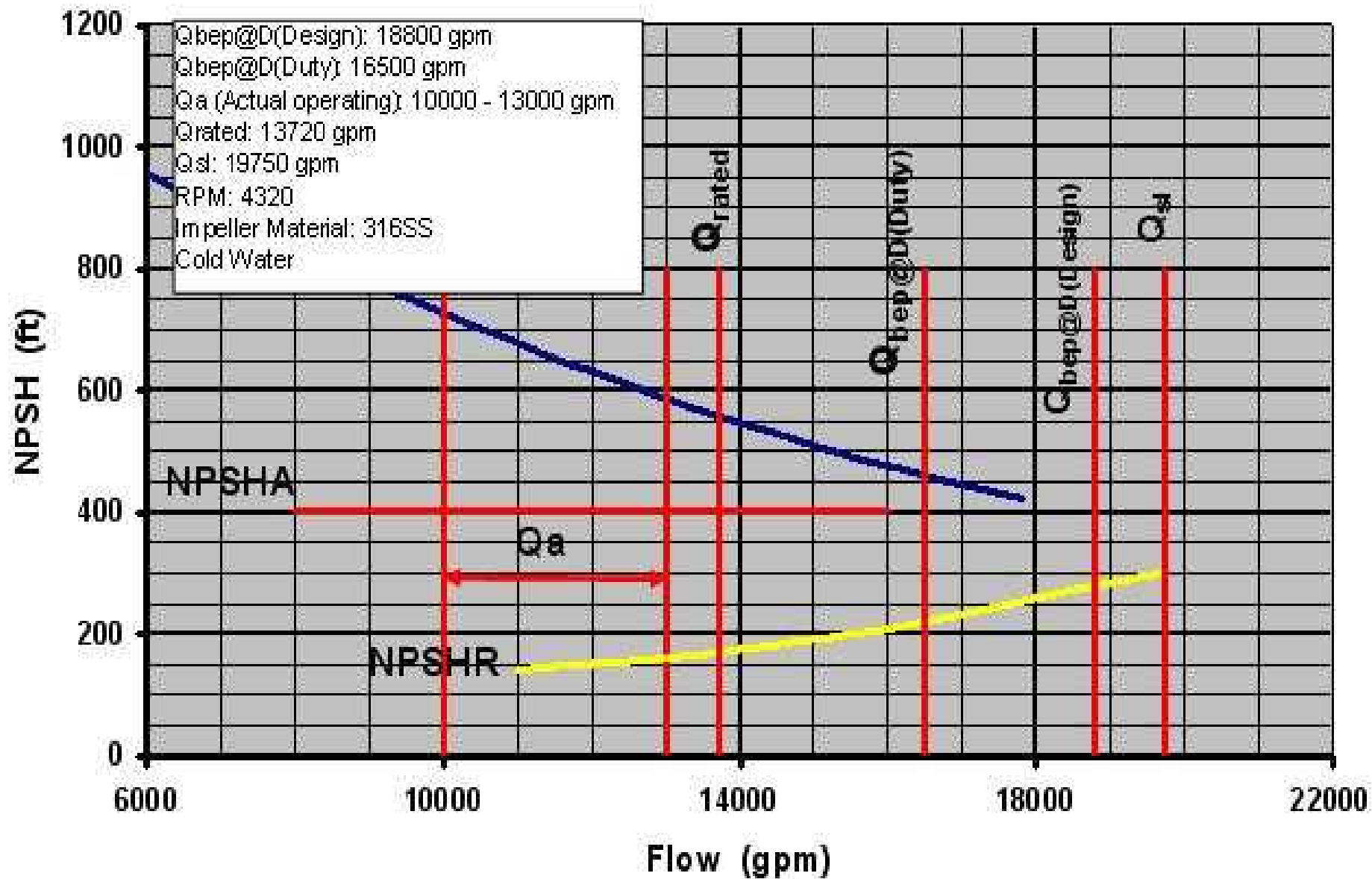

Cavitation Damage Root Cause

Cavitation damage on the vane suction side because :

- $Q_{oper} < Q_{shockless}$ and
- $NPSHA < NPSH_{40000} < NPSH_{inc}$

Cavitation damage rate is too high because :

- Impeller design is oversized for the rated capacity
- Actual operating capacity is even below the rated flow
- Pump speed is too high giving high $NPSH_{40000}$
- Booster head is undersized giving insufficient $NPSHA$ for achieving acceptable impeller life (40,000 hours = 5 years)
- High Oxygen content has been likely an aggravating factor

2- Pitting Corrosion

- High oxygen content in the process fluid.
- Aggressive Working Fluid (Raw Water from Hanifa Zone)

Chemical Analysis:

Ions	Field Sample Analysis (PPM)	Anticipated Sample Analysis (PPM)
Sodium (Na)	7322	4832
Calcium (Ca)	1472	496
Magnesium (Mg)	224	93
Sulphate (SO ₄)	907	1001
Chloride (Cl)	13746	7668
Bicarbonate (HCO ₃)	259	329
TDS	23930	14419
Specific Gravity	1.0210	0.98

Recommendations

- Review / confirm the expected operating range
- New pump design (impeller with smaller shockless capacity)
- New pump speed and configuration
- Review pump booster head
- Reevaluate the oxygen scavenger system
- Reduce Oxygen content
- Upgrade impeller material (higher resistance to cavitation damage)

Thank you

Pitting Corrosion on Pump Casing



Corrosion on Pump Shaft



Pump Impeller as Received



BACK

Cavitation On The First Stage Impeller Vanes



Water Box as Received

