

TOWARD REDUCED PUMP OPERATING COSTS, PART 3— MINIMIZING THE EFFECTS OF WEAR AND OPTIMIZING PUMP EFFICIENCY

by

James P. Netzel

Senior Staff Engineer

John Crane Inc.

Morton Grove, Illinois

and

Eugene P. Sabini

Director of Technology

ITT Industries

Fluid Sealing Technology Group

Seneca Falls, New York



James P. (Jim) Netzel is a Senior Staff Engineer at John Crane Inc., in Morton Grove, Illinois. He joined them in 1963 and has more than 38 years' experience in the science of sealing technology for improving equipment reliability. For 20 years he has served as Chief Engineer. Mr. Netzel's accomplishments include five patents and numerous technical papers and articles published through the International Pump Users Symposia, STLE, ASME, BHRA,

AISE, and various trade publications. He has contributed chapters to the Pump Handbook and the Centrifugal Pump Handbook.

Mr. Netzel received his B.S. degree (Mechanical Engineering, 1963) from the University of Illinois. He is a Society of Tribologists and Lubrication Engineers (STLE) Fellow and is on their Board of Directors. He is past Chairman of the ASME/STLE International Tribology Conference and the STLE Seals Technical Committee. He is an Associate Editor and Editorial Advisory Board member to three industrial trade publications.

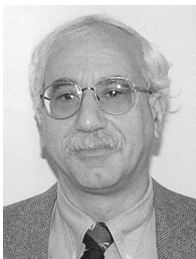

Eugene P. (Gene) Sabini is the Director of Technology for ITT Industries, Fluid Technology Group, in Seneca Falls, New York. He is responsible for applied research and hydraulic design of all new products and field rerates. Other responsibilities include testing, FEA, CFD, rotordynamics, rapid prototyping, and condition monitoring. Mr. Sabini was previously Manager of Energy Engineering Design with Goulds. He was responsible

for both the product engineering and the mechanical/hydraulic design and testing of the energy related double suction and multistage API pumps.

Mr. Sabini has 32 years of experience in the pumping industry including design and development of many centrifugal pumps for the chemical, API, power utilities, and municipal industries. He spent 25 years with Worthington Pump designing, engineering, and testing custom centrifugal pumps from both a mechanical and hydraulic standpoint.

Mr. Sabini received a BSME (1968) and M.S. (1975) degree from Stevens Institute of Technology.

ABSTRACT

This tutorial will help the user to distinguish between premature failure and failure due to the normal wear-out process. Once the normal wear-out process has been identified, then what technologies can be used to minimize the effects of wear to the pump and its component parts? Solving wear problems to component parts like seals, bearings, and couplings will have a beneficial effect on increasing pump efficiency. In the United States alone, the ANSI pump population is greater than 750,000 units. The average mean time between repair (MTBR) is 18 months and the average cost to repair is \$2500 per unit. For the ANSI class of pumps alone, billions of dollars will be spent throughout the life of the equipment that was purchased on the basis of a 20-year life. In controlling infant and premature failures as well as minimizing the effects of wear, what equipment life should the user expect? The information presented will help to identify system life based on classes of service found in the refining and chemical process industries.

INTRODUCTION

To make a major impact on plant operating cost, one must have a fundamental knowledge of tribology and reliability engineering.

Tribology

Tribology is a modern science used to combat wear of machinery and its component parts. It is the study of friction, wear, and lubrication. Tribology involves fluid and machine dynamics, material properties, physical and surface chemistry, heat transfer, and stress analysis. A large number of machine components have achieved exceptional levels of performance and service life with the application of tribological principles and techniques. Among these components are:

- Journal bearings
- Thrust bearings
- Rolling element bearings
- Ball bearings
- Face seals

Hydrodynamic Lubrication

This condition exists when the fluid film completely separates sliding surfaces of a machine element. Under these conditions, direct surface-to-surface contact does not occur and wear as well as frictional heat is eliminated. An example of this type of system is a noncontacting gas lubricated seal used on difficult pumping applications.

Elastohydrodynamic Lubrication

This system is also known as EHD. Elastohydrodynamic lubrication is more commonly found in rolling surfaces separated by an oil film. Here the moving parts elastically deform under contact pressure, creating larger lubricating films to carry even greater loads. This method of lubrication is typically used in rolling element bearings.

Boundary Lubrication

Slow moving surfaces under heavy load are dependent on absorbed films created by chemical interaction between the surfaces and the fluid used as a lubricant. Typically, boundary lubrication exists when equipment is started or shut down or when speeds are too slow to generate adequate lubricating films.

Mixed Film Lubrication

As the term implies, this is a combination of the other lubrication systems. Here the lubricating film at the sliding surfaces is part liquid and part gas. An example of mixed film lubrication can be found in a contacting mechanical seal face design used to seal a light hydrocarbon as a liquid. A portion of the fluid film at the seal face is liquid, while the remaining portion is gas. For long life, the fluid film must have a larger percentage of liquid than gas.

Reliability Engineering

In Parts 1 and 2 of this tutorial series, various terms in reliability engineering were presented. The purpose was to gain an understanding of terms used, mean time between failure (MTBF), and the types of failure that can occur. The most important definition given was that of mechanical reliability.

Mechanical reliability is the *probability* that a *component, device, or system* will perform its prescribed *duty* without *failure* for a given *time* when *operated correctly* in a specified environment.

This is a very strong definition that must be used as a guide to improving reliability and operating life. The failure of any piece of equipment to perform its function can be traced to a failure of a component part within the mechanical system. For example, an automobile can fail to perform its intended function when the engine water pump has failed.

The types of failure that can occur may be listed as:

- *Infant mortality failure*—In this case, the failure of a device or component occurs in less than one year. Failures that occur at startup or every three to four months are infant mortality failures.
- *Premature or chance failures*—A failure that occurs prior to the wear-out phase of the equipment.
- *Wear-out failure*—As the name implies, a component that has simply worn out and can no longer function in the intended environment.

In reliability engineering, the types of failures described can be illustrated on what is referred to as the bathtub curve (Figure 1). Infant mortality and premature failures must be eliminated. Then changes in design or operation must be made to reduce or eliminate wear-out failures (Figures 2 and 3).

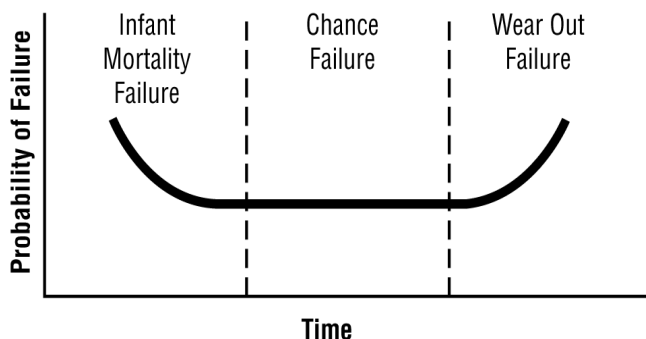

Figure 1. Concept of the Bathtub Curve.

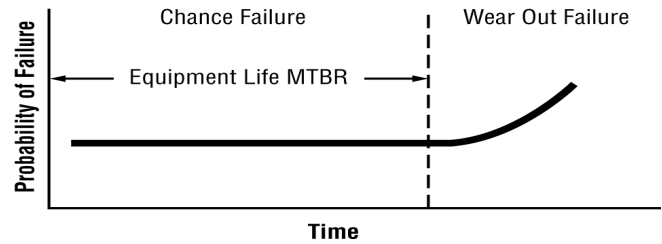

Figure 2. Modified Shape of the Bathtub Curve, Infant Mortality Phase Eliminated.

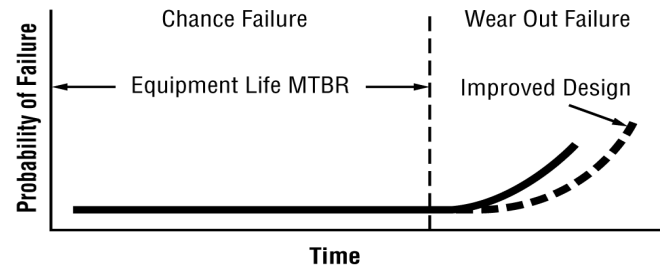

Figure 3. Modified Shape of the Bathtub Curve, Chance and Wear-Out Failures Approach Zero.

A strong plant reliability program must be capable of identifying classes of component failures and implementing the corrective measures to increase MTBF. This can be accomplished by working together with suppliers to continually monitor the equipment and identifying the cause for failure.

Mean Time Between Failure (MTBF)

Enough cannot be said about having a consistent approach to measuring MTBF. For it is with this measurement that priorities are set to improving reliability and life.

For pumps, in a process plant environment, the mean time between repair (MTBR) can be measured as:

$$\text{MTBF} = \frac{\text{Total Number of Pumps}}{\text{Total Number of Failures}} \times \text{Review Period} \quad (1)$$

Adjustments for spared pumps can be made (Wallace, et al., 2000).

For seals, a similar measurement is recommended:

$$\text{MTBF} = \frac{\text{Total Number of Seals}}{\text{Total Number of Failures}} \times \text{Review Period} \quad (2)$$

Adjustments can be made for between bearing pumps (two seals) (Wallace, et al., 2000).

A pump will fail when any one of its component parts fails. This is referred to as a series system. A series system is illustrated in Figure 4.

The component parts are the seal, bearing, coupling, and shaft. If any one of these parts fails, the pump can no longer function as intended and must be repaired. In our analysis, the mean time between failure can be determined with the following equation:

$$\frac{1}{M_5^2} = \frac{1}{M_1^2} + \frac{1}{M_2^2} + \frac{1}{M_3^2} + \frac{1}{M_4^2} \quad (3)$$

The calculated MTBF for a series system is limited to the shortest component life. Therefore, the major effort to improve equipment reliability must focus on improving the shortest component life.

Pumps are purchased on the basis of a 20-year life. Yet experience has shown that the majority of pumps are repaired every 18 months. If the average cost for repair is \$2500 per pump,

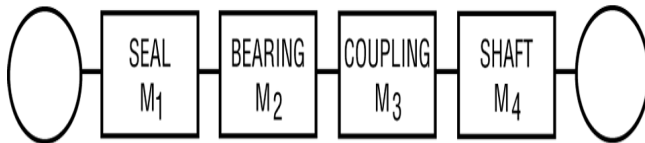

Figure 4. A Series System for an ANSI Pump.

then a total spend for 13 repairs over 20 years would be \$36,400 per pump. This value does not include inflation, which would result in a large cost over the life of the equipment. If the life of the equipment were increased by a factor of two, the cost of repair would be \$18,200 per pump. Opportunities exist for significant savings to the user by increasing equipment life. When the cost of process downtime is considered, then the savings are even greater.

TYPES OF WEAR

Wear is a familiar phenomenon in our daily lives. Most notably, the tires on the vehicles that we drive wear over a period of time and must be replaced. In industry, there are numerous examples where a small amount of wear destroys the usefulness of a critical mechanical component. The cost to industry is severe. In fact, billions of dollars per year can be saved by increasing the life of components within a machine. Pumps represent a major area for savings.

A key to controlling costs is to identify the type of wear that is occurring and applying the appropriate solution to eliminate wear or at least minimize its effects. There are several types of wear that can be found in pumping equipment. These have been identified as:

- Adhesive
- Abrasive
- Corrosive
- Fatigue, pitting, or blistering
- Impact
- Fretting
- Erosion

Suppliers of component parts are an excellent resource of information for plant maintenance and reliability teams. Working with suppliers, the results will be excellent in improving equipment life.

Adhesive wear is the dominant type of wear in component parts such as seals and bearings. Even when good lubricating fluid films exist at the contact surfaces, wear occurs during startup, shutdown, and during changes in equipment operating conditions.

For seals, the primary ring is usually made of carbon graphite and considered to be the wearing part in the seal assembly (Figure 5). The mating ring surface will also wear, but to a lesser extent. Face loads, by design, are sufficiently low enough that only mild adhesive wear occurs. This is necessary in the design to prevent the vaporization or carbonization of the fluid being sealed. If vaporization or carbonization occur, there is a substantial reduction in seal life.

For bearings, the rolling contact surfaces are made of alloy steel and have a hardness of R_C60 (Figure 6). These components are normally lubricated by oil, which generates the lubricating film at the bearing contact surfaces. Here the user has complete control in providing excellent environment to operate the bearing. Moisture must also be kept out of the bearing area to extend life and eliminate wear.

Abrasive wear frequently limits the life of seals, bearings, impeller, and pump casing. Abrasive wear problems for seals can result from:

- *Internal abrasives in the seal chamber*
 - Abrasives suspended in the fluid sealed
 - Abrasives in solution in the fluid sealed

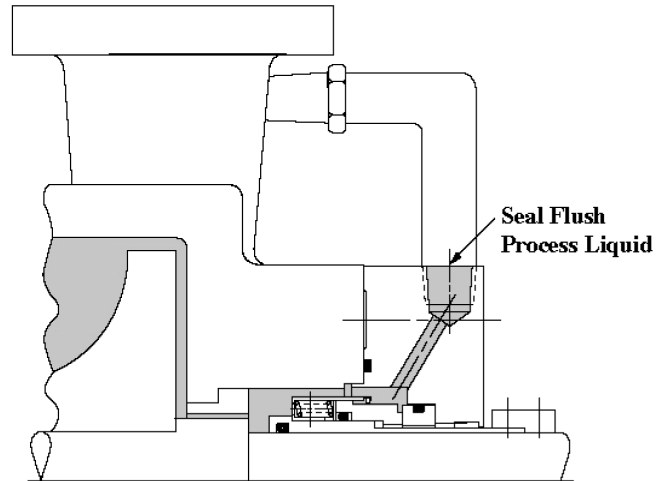

Figure 5. Typical Mechanical Seal Design.

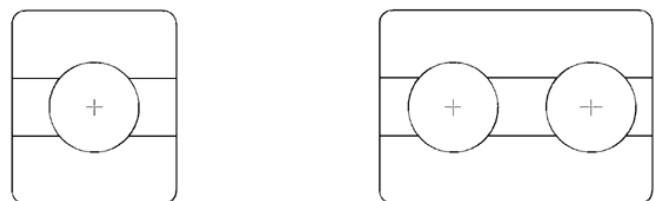

Figure 6. Common Types of Rolling Element Bearings Used in Pump Design.

- *External abrasives*
 - Abrasives from the environment such as sand and dirt

Abrasive wear particles that penetrate the sealing surfaces will cause accelerated wear and leakage.

Wear particles that are suspended in the product being pumped may be part of the fluid being pumped, products of corrosion within the system, machining burrs that have broken off in operation, sand, and other abrasives found in the system.

API Standard 610 (1995) identifies several piping plans to eliminate abrasives from the seal chamber. API Plan 31 covers the use of a cyclone separator. Here fluid is taken from the pump discharge through a separator. The clean flow from the separator is brought to the seal chamber for the purpose of flushing the seal chamber to cool the faces, but also to help keep the abrasives out of the seal area. Care must be taken so that the dirty discharge of the separator and the clean flow to the seal chamber are at equal pressures. If the pressure of the dirty discharge line is at a lower pressure than the seal chamber, then all the flow will be to the dirty discharge line, which will starve the seal chamber of clean liquid. The seal will run hot and fail.

API Plan 41 is used when a hot process fluid is pumped that contains suspended abrasive particles. Flow from the discharge of the pump enters the cyclone separator and delivers clean flow to the seal chamber through a heat exchanger. Solids are delivered from the separator to pump suction in the same manner as Plan 31. Again, care must be taken so that the clean discharge to the seal chamber and the dirty discharge to pump suction are at equal pressures.

To determine if a cyclone separator can be used on a given application, a small container with the fluid and abrasive is shaken. If in a few minutes the abrasive settles out, then a separator can be used.

Another method of keeping an abrasive from the seal chamber is with API Plan 32. In this case, a separate fluid from the pumpage is injected from an external source. Care must be taken in selecting the external fluid for injection. The injection fluid must provide good lubrication to the seal and eliminate the potential for vaporization,

thereby avoiding contamination of the pumpage with the injected fluid. These piping plans are shown in Figures 7, 8, and 9.

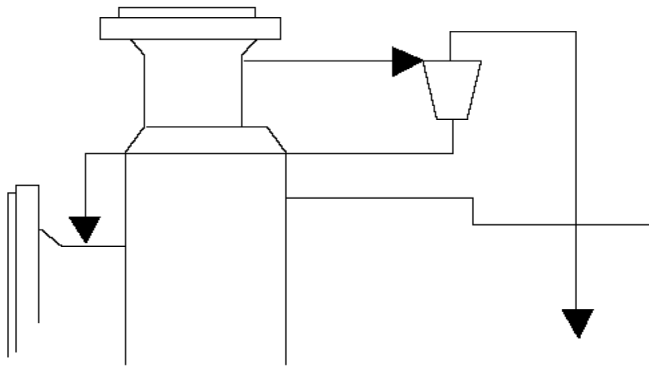

Figure 7. API Plan 31—Use of a Cyclone Separator.

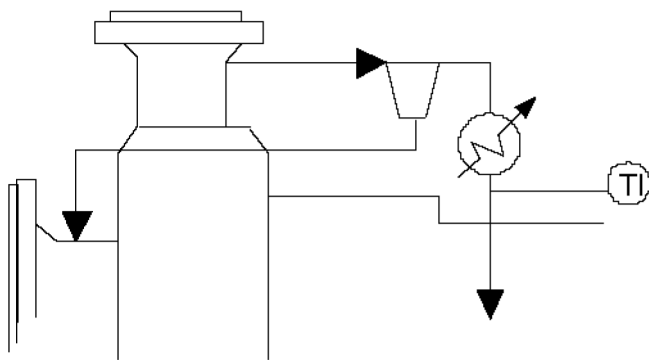

Figure 8. API Plan 41—Use of a Cyclone Separator on Hot Fluids.

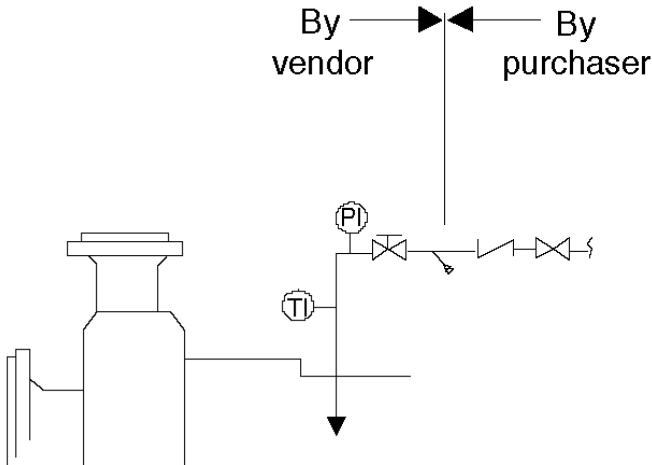

Figure 9. API Plan 32—Clean Fluid Injection from an External Source.

In some cases, the abrasive will already be in solution in the fluid being pumped. As the fluid evaporates on the atmospheric side of the seal, abrasive crystals will be left to wear away the inside diameter of the seal faces. Here a quench fluid should be considered to wash away the abrasive particles. The quench fluid is normally water.

On high temperature applications, steam will be considered as the quench fluid. API Plan 62 will be used. Typically, a close clearance bushing will be used to limit quench fluid escaping to atmosphere.

External abrasive wear particles will come from sand and dirt entering the seal area from the environment. External enclosures will help to limit abrasives getting into the seal area.

Abrasive particles will become partly embedded in the softer of the seal faces and will then act as a cutting tool, shearing material from the mating surface.

Corrosive wear is commonly found in an industrial environment where seals are exposed to a variety of chemically active process fluids. High temperatures at the seal faces from sliding contact will promote chemical activity and wear. This type of wear can be eliminated by the selection of the most chemically inert materials for the process.

Fatigue wear including pitting and blistering of material are considered as a group. Pitting of a seal or bearing surface is associated with fatigue. Blistering, usually occurring on carbon graphite materials, is attributed to subsurface porosity filling with the liquid being sealed and subsequently vaporized by the frictional heat at the seal faces. The resulting pressure lifts a portion of the surface to form a blister. Blisters will also be found on applications with high viscosity fluids. Blistering may be eliminated by considering a harder seal face combination of materials that have low coefficients of friction.

Impact wear occurs when components such as seals are subject to instability and/or high vibration. The rocking of one part against another is extremely destructive and results in edge chipping of one of the seal faces. This can result from liquid vaporizing at the seal faces or mechanical misalignment of the equipment.

Fretting wear normally occurs on the secondary sealing surfaces when the seal is subject to axial motions transmitted to the seal. Here motion transmitted to the seal must be eliminated.

Erosion of component parts such as a mating ring in a seal assembly is the result of abrasives in the fluid stream used as a flush to cool the seal. This may also be caused by the high velocity of fluid flow to the seal chamber. Control of abrasives and the velocity of flow in the seal chamber can eliminate erosion problems.

ANALYSIS OF COMPONENT FAILURES

Improving equipment reliability begins with a basic understanding of the function of each component part and its limits of operation. Overstressing the critical parts of a pump must be eliminated to achieve maximum life.

Seals

The major cause for pump repairs is due to a leaking seal. The problem of short life may be a symptom of another problem that is affecting the performance of the pump. Also, at least 20 percent of short life problems are the result of poor or incorrect seal installation. A successful seal installation not only depends on the correct installation of the pump, but also the correct installation of the seal to the pump. Motion transmitted to the seal must be kept to a minimum to achieve exceptional results. Motion can be transmitted to the seal faces from misalignment (angular or parallel), end play, or radial runout of the pump as shown in Figure 10.

Angular misalignment occurs when the mating ring in the seal assembly is not square with the shaft. As the shaft turns, the primary ring must follow the mating ring. If the surface of the seal is out by 0.005 inches total indicator reading (TIR) then at 3600 rpm, the seal face must move 0.005 inches 3600 times per minute. The resulting motion will overstress the seal materials as well as cause fretting wear on the shaft or seal hardware.

An example of damage to a seal face from angular misalignment is shown in Figure 11. The seal face or primary ring is from a 5.375 inch diameter seal operating at a surface speed of 5000 fpm in water at 180°F. The seal chamber pressure was 150 psig. Misalignment resulted in edge chipping at the seal faces. This damage occurred opposite the drive notch in the carbon ring. The highest axial force due to friction at the drive mechanism will occur at this point on the seal ring. Chipping occurs due to the constant impact of the seal faces for each revolution. This failure

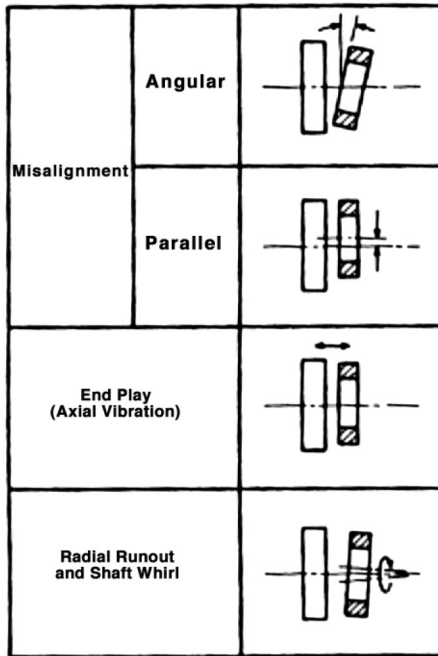

Figure 10. Common Types of Motion Transmitted to a Seal.

occurred after two months of operation. Surface waviness, a measure of flatness, was 2550 microinches of flatness through 360 degrees. A new seal face will measure 22 microinches of flatness. The surface profile, a measurement from face OD to ID, was irregular from convex to concave ranging from 200 to 350 microinches every 90 degrees. As noted in the figure, the O-ring seal is completely worn and broken. This damage is the result of motion transmitted to the seal from misalignment. This type of result in varying degrees is from angular misalignment. Correcting the cause has resulted in a significant improvement in life.

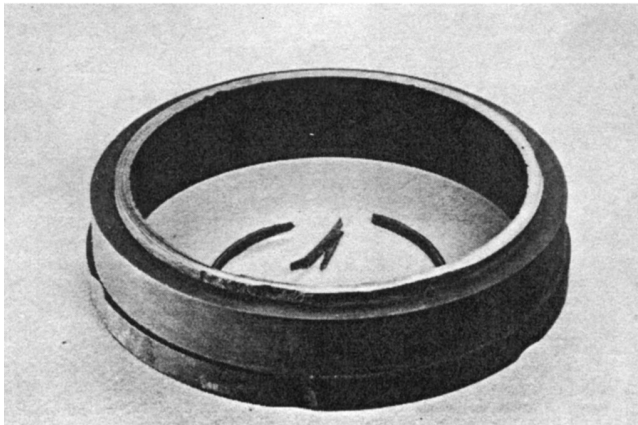

Figure 11. Damage to a Seal from Angular Misalignment.

Parallel misalignment results when the seal chamber is not properly aligned with the rest of the pump. No seal problems will occur unless the shaft strikes the inside diameter of the mating ring. This type of damage is shown in Figure 12. If damage has occurred, there will also be damage to the bushing at the bottom of the seal chamber at the same location as the mating ring.

Excessive axial end play can damage the seal faces and can cause fretting wear on the shaft or sleeve. If the seal is continually being loaded and unloaded, wear debris can penetrate the seal faces and cause premature wear of the seal faces. Damage can also be in the form of heat checking or cracking shown in Figure 13.

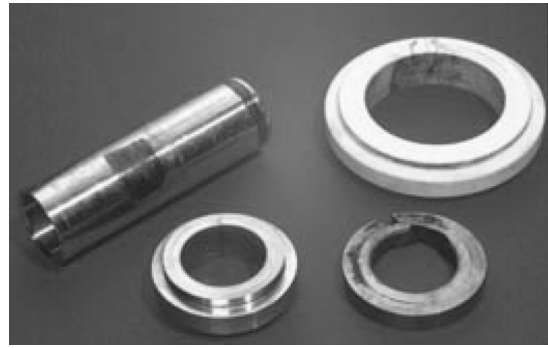

Figure 12. Damage to a Seal from Parallel Misalignment.

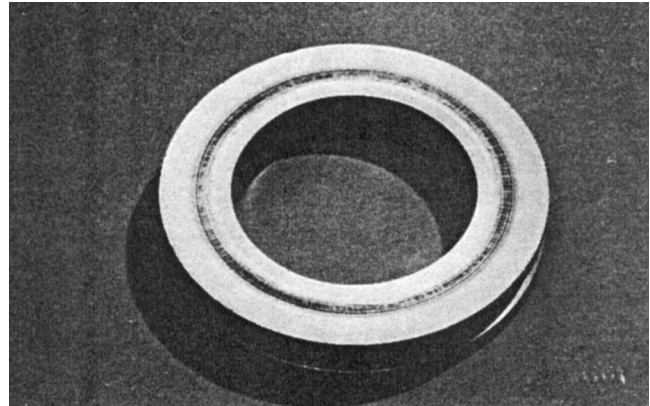

Figure 13. Heat Checking of a Seal Face.

Erosion of a seal face may take one of two forms. Shown in Figure 14 is erosion on the outside diameter of the carbon seal ring as well as on the seal face. On the outside diameter, the seal flush with abrasives present has worn away much of the carbon ring. This is easily solved by redirecting the flow to the seal and by removing the abrasive from the seal flush as previously discussed.



Figure 14. Damage to Outside Diameter of a Seal from Erosion.

The second form of erosion on the seal face is referred to as wire drawing. This occurs when the pump is idle and the mating seal surface is distorted. Eliminating the distortion will eliminate the erosion.

Another form of erosion to a seal face is shown in Figure 15. This condition of wear is referred to as wire brushing. This occurs when abrasives are present in the seal chamber and the seal is operated with a mechanically distorted mating ring. Again, the distortion must be eliminated to achieve long life.

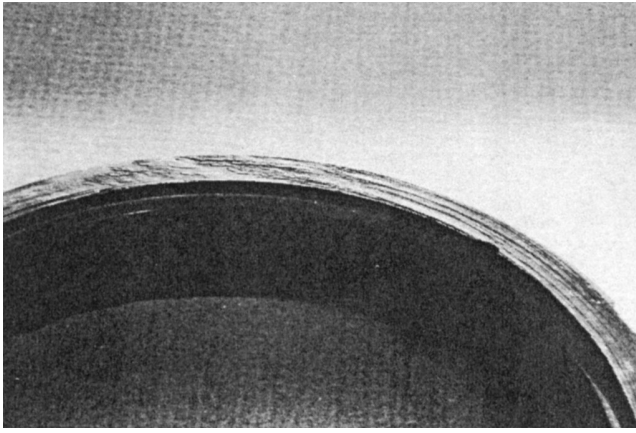

Figure 15. Erosion Damage of a Seal Face.

Corrosive wear is shown in Figure 16. Here corrosion is accelerated due to the higher temperature at the seal faces. Once the corrosion and wear cover the entire seal faces, leakage will occur. Material selections should be made carefully to avoid this problem.

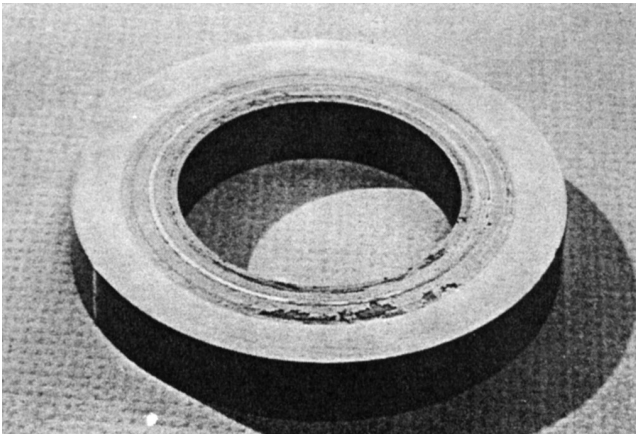

Figure 16. Damage to a Seal Face from Corrosive Wear.

Finally, when a seal has been properly selected, installed, and operated, the results will be years of trouble-free service. The seal shown in Figure 17 has been in service for over 25 years. This is over 200,000 hours of operation. This 3 inch seal was used to seal gasoline, fuel oil, and occasionally propane. Normal operating pressure and temperatures were 800 psig and 60°F. Shaft speed was 3560 rpm. The condition of the carbon ring exhibits virtually no adverse wear of the sealing face or at the drive notches, which represent the drive system on this seal. Wear at the carbon seal face is only 0.032 inches for this length of time in service. The mating ring is in good condition. This seal was not leaking even though some minor heat checking had occurred. It is believed this occurred as the O-ring aged in service increasing in hardness from 70 to 90 durometer. This increase in hardness would eventually lead to a loss of flexibility for the seal head.

This seal face was not subject to any excessive amount of angular and axial motion. Alignment of the equipment, both external and internal, was excellent. The amount of heat developed by the seal was easily removed by a seal flush. Also, all of the fluids handled, with the exception of propane, are good lubricants for the seal. During the service life of 25 years, no maintenance expenses on this pump were incurred by the plant operator. Paying attention to every detail in the design, installation, and operation of the equipment will result in exceptional life.

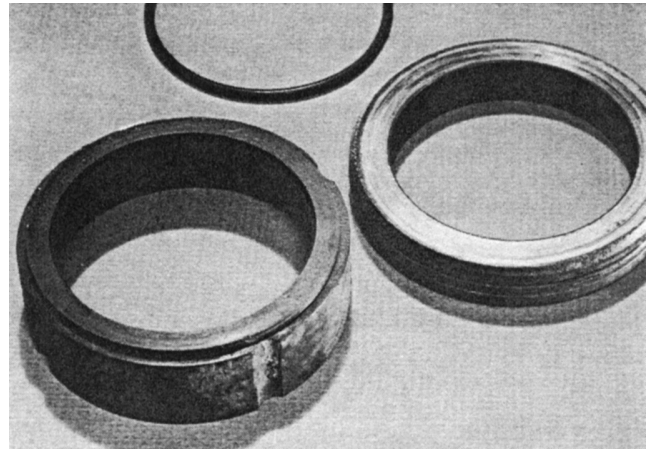

Figure 17. Seal Faces Operated Successfully for 25 Years.

Bearings

Bearings applied to pumps typically fall into two categories:

- Antifriction type (rolling element)
- Hydrodynamic type (fluid film)

For maximum reliability, bearings must be selected, applied, and maintained properly. If the supplier or user does not follow good practices, premature failure will occur.

The bearing type should be selected based on the pump type (end section, between bearing, and multistage, etc.), service temperature, speed, and loads (steady-state and dynamic). The following criterion has been established for the proper selection of bearings.

Rolling Element—Radial and Thrust

$N < N_{RE}$ both radial and thrust bearing (Figure 18)

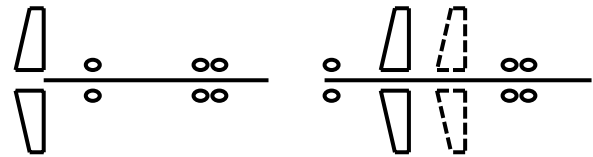

Figure 18. Rolling Element—Radial and Thrust.

$L_{10} > 25,000$ hr continuous rated (API)
 $> 17,500$ hr min to 110 percent rated capacity (ANSI)
 $> 16,000$ hr max loads (API)

$Nd_m < 50,0000$

kWN (hpN) $< 4,000,000$ (5,400,000)

Hydrodynamic Radial and Rolling Element—Thrust

$N < N_{RE}$ thrust bearing (Figure 19)

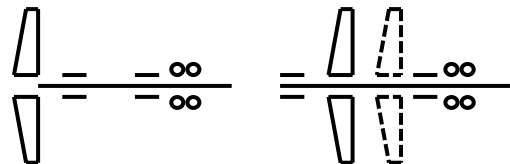

Figure 19. Hydrodynamic Radial and Rolling Element—Thrust.

$L_{10} > 25,000$ hr continuous rated (API) thrust bearing
 $> 17,500$ hr min to 110 percent rated capacity (ANSI) thrust bearing
 $> 16,000$ hr max loads (API) thrust bearing

$N_{d_m} < 500,000$ thrust bearing

kWN (hpN) < 4,000,000 (5,400,000) thrust bearing

Hydrodynamic—Radial and Thrust

Rating outside the above limits (Figure 20).

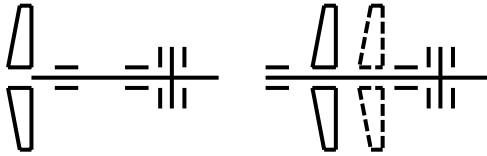

Figure 20. Hydrodynamic—Radial and Thrust.

where:

N = Pump speed, rpm

d_m = $(d + D)/2$, mm. Note, d is the bearing ID and D is the bearing OD.

N_{RE} = Rolling element speed (radial and/or thrust) limit, rpm

L_{10} = Basic rating (rolling element) life, hr, ISO 281 (ANSI/ABMA Standard 9)

kW (hp) = Pump power, kW (hp)

Bearing failure often occurs during pump startup because of problems with baseplate installation, piping installation/design, alignment, and using pumps as pipe anchors, which tend to distort the casing transmitting higher than expected loads to the bearings. Other problems encountered are that pumps typically operate at much lower than normal flows also causing higher than expected steady-state and dynamic loads. The dynamic portion of the load, particularly on high-energy pumps, can approach, or even exceed, the steady-state loads in value. These dynamic loads, caused by internal recirculation, have a very random high frequency content. These dynamic loads produce pounding at the bearing fits, which causes bearing surfaces to overheat leading and premature failure. Table 1 summarizes problems typically encountered at flows other than normal. Steady-state and dynamic loading on a centrifugal pump is illustrated in Figure 21.

Table 1. Problems Encountered at Abnormal Flow Conditions.

OPERATION	PROBLEM
Low Flow Region	Increased discharge pressure Increased axial loads Increased radial loads Increased dynamic loads Recirculation Increased vibrations
Run Out Region	Decreased discharge pressure High/steep NPSHr Curve Shape Increased radial loads Increased dynamic loads Increased vibrations

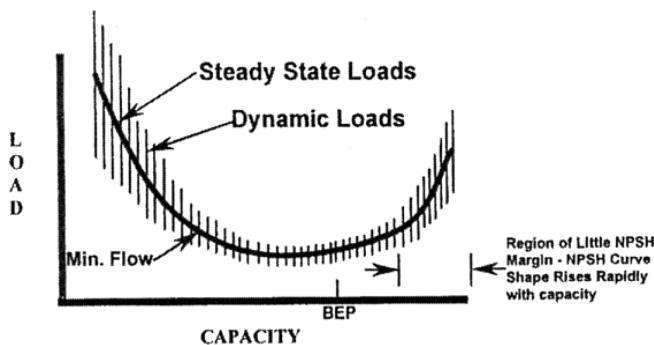

Figure 21. Pump Load-Capacity Curve.

All bearings require proper lubrication for optimal life. Proper lubrication means supplying clean lubricating fluid, of the correct

type, quantity, and viscosity for the loads and temperatures encountered by the bearings.

Rolling element bearings are typically lubricated by the following methods:

- Grease
 - Greased for life
 - Grease packed
- Sump
 - Flooded oil—Submerged approximately $1/4$ to $1/3$ the ball (roller) diameter
 - Ring oil—Submerged $1/8$ inch
 - Flinger—Submerged $1/8$ to $1/4$ inch
- Mist
 - Pure—Constantly supplies cool, clean lubricating oil
 - Purged—Sump plus pure mist

If the grease-lubricated bearings are over packed or oil sump lubricated bearings are submerged too greatly, the bearing will run hot, which in turn diminishes life.

Hydrodynamic bearings are typically lubricated by the following methods:

- Lube oil pressure systems—Constant supply of cool, clean lubricating oil
- Sump—Typically ring oil submerged $1/8$ inch
- Mist
 - Pure—Constantly supplies cool, clean lubricating oil
 - Purged—Sump plus pure mist
- Product lubrication typically flooded or pressurized

Rolling element bearings most often fail because of contamination and oil degradation occurring within the bearing housing. Contamination from particles causes rolling element bearing fatigue to occur by spalling the bearing surface. Spalling occurs when the contamination particles penetrate the lubrication film. These particles make contact with both bearing surfaces denting the bearing surfaces. The dents produce stress risers and through repeated contact produce cracks that propagate through the steel. Repeated contact produces a spalling pit.

Oil degradation leads to contamination-like problems as the oil film deteriorates. Contamination, organic acids, metallic catalysts, and free water accelerate oil degradation. Organic acids (measured by total acid number, TAN) increase both oil oxidation levels and oil residues (varnishes and gums) concentration. An increase in oil oxidation leads to the development of “free-radicals,” which breaks down oil into other products. This in turn leads to further oil degradation. Varnishes and gums restrict lubrication, which affects the oil thickness, which in turn accelerates the process.

Metallic catalysts also accelerate the formation of “free-radicals,” which breaks down oil into other products. This leads to further oil degradation, which also accelerates the process.

Water has been found to accelerate fatigue spalling. Free water corrodes steel surfaces, which penetrates deep into cracks and accelerates crack propagation, thereby reducing overall fatigue life.

Hydrodynamic bearings fail most often because of:

- Contamination particles embedded in the bearing surface causing wear, which leads to a breakdown of the hydrodynamic film required for rotor support.
- Lack of lubrication—particularly on product lubricated bearings, causing excessive heat buildup on the bearing surfaces, which usually leads to catastrophic failure.

During routine maintenance, care must be taken not to overlubricate (overgrease or increase oil level), introduce contaminants (grit, dirt, or moisture), and use the wrong lubricant or mix incompatible lubricants. Use procedures that will avoid damaging bearing, shaft, housing, and closure fits. Avoid excessive heating of bearings during installation. Use correct replacement bearings (cage materials, clearance, etc.)

Adams, et al. (1996), proposed the following life charts (Figures 22, 23, and 24), which can be used to adjust rolling element bearing L_{10} life for both contaminant size and water concentration.

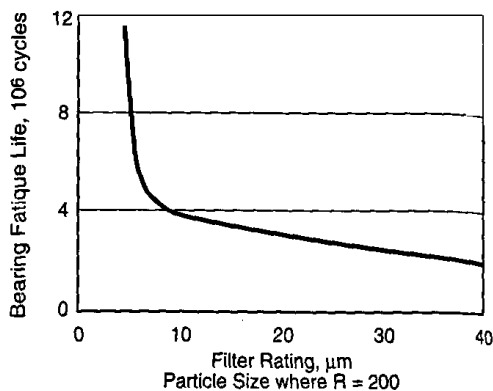

Figure 22. Bearing Life Versus Level of Friction.

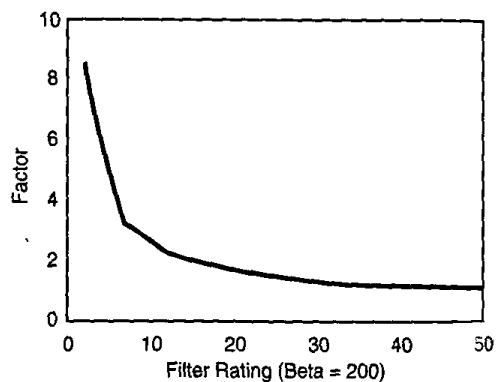

Figure 23. Bearing Life Factor Versus Filter Rating.

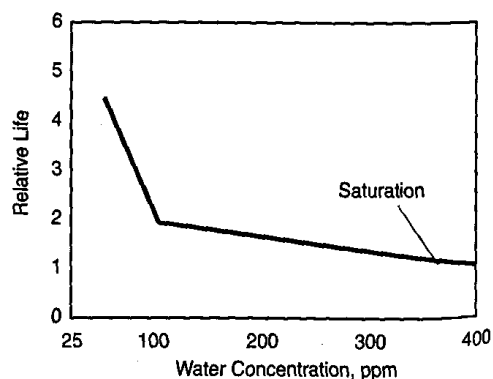

Figure 24. Relative Bearing Life Versus Water Concentration.

Couplings

Misalignment between the pump and motor can cause unacceptable pump/pumping system vibrations as well as effect mechanical seals, wear parts (rings, bushings, etc.), and bearing life. The vibration levels encountered are a function of both the amount of misalignment and the type of coupling used. The choice of the proper coupling type can help increase overall pumping life.

It should be noted that one could not expect the coupling to make up for any deficiencies in piping design or field in alignment, which transmits larger than required moments and forces to the pump. The pump must never be used as an anchor for the piping. Alignment of the motor to the pump should be done in accordance with best practices and at the very least should follow PIP REIE 686 (API Recommended Practice 686, 1996) "Recommended Practices for Machinery Installation and Installation Design."

Failure to have good alignment will result in the coupling being overstressed. Figure 25 illustrates a stress crack found in a misaligned coupling. Had this not been discovered, a catastrophic failure would have occurred. This failure did not set off the vibration alarm and was found by visual inspection.

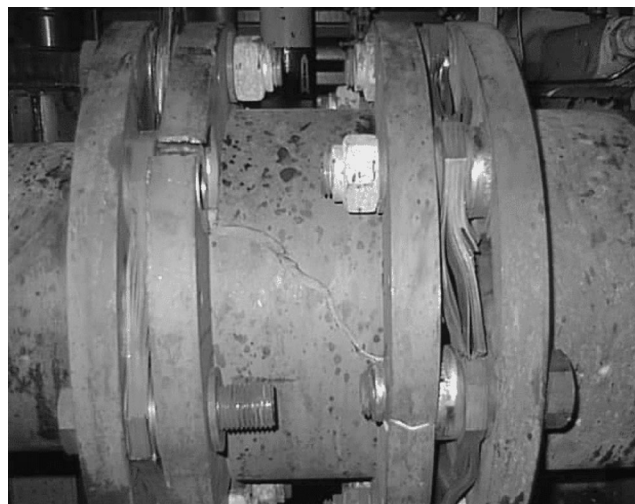

Figure 25. Stress Crack in a Coupling from Misalignment.

Lorenc (1991) tested various types of couplings for their ability to withstand misalignment. The types included:

- Steel—flexing beam
- Steel—gear
- Steel—grid
- Steel—disk
- Elastomer—shear
- Elastomer—compression
- Elastomer—flexing beam

The test indicated that the steel flexing beam type coupling withstood the most amount of misalignment without a significant increase in vibration.

Wear Surfaces

Maintaining wear surface gap (clearance, finish, hardness, etc.) is required for proper pump operation. As clearances open up, due to internal contact, erosion, corrosion, thermal expansion, etc., leakage increases, pumps lose efficiency and head, axial thrust increases, and hydrodynamic support decreases leading to failure.

Wear surfaces usually comprise the following types:

- Wear plate (open impellers)
 - Used to break down pressure and control leakage
 - Maintains pump efficiency and curve shape
- Wear rings (enclosed impellers)
 - Used to break down pressure and control leakage
 - Maintains pump efficiency and curve shape

- In the case of high-pressure multistage pumps, adds hydrodynamic support to rotors
 - Also used to maintain/control axial thrust
- Balancing disks/drums
 - Used to control axial thrust in high-pressure multistage pumps
 - Used to control leakage
- Throttle/break down bushings
 - Used to break down pressure and control leakage
 - Maintains pump efficiency and curve shape
 - In the case of high-pressure multistage pumps adds hydrodynamic support to rotors
- Bushings
 - Used to isolate mechanical seal chamber from pump suction

PUMP RELIABILITY FAILURE MATRIX

Table 2 can be used as a guide to determine likely component failure for problems encountered. From Table 2, it can be determined that an alignment problem will result in a failure at the seal, bearing, or coupling. Operating the pump dry will result in failure of a liquid lubricated seal. This failure matrix helps to bring visibility to areas that need attention to increase reliability.

Table 2. Pump Reliability Failure Matrix.

PROBLEM	FAILURE MATRIX				
	SEAL	BEARING	IMPELLER	CASING	COUPLING
Alignment	4	5	--	--	5
Forces and Moments	4	5	--	2	5
Balance	2	4	--	--	3
Structural Acoustical Resonance	4	4	--	--	--
Low Flow Operation	5	4	4	1	--
Cavitation	4	4	4	--	--
Dry Run	5	--	--	--	--
Bearing Lubrication	--	5	--	--	--
Seal Face Lubrication	5	--	--	--	--
Entrained Solids in Liquid	4	--	4	3	--
Entrained Gas in Liquid	4	--	--	--	--

Severity rating – 5 being most severe

UNDERSTANDING THE CONCEPT OF WEAR ON PUMPING EQUIPMENT

In the normal course of maintenance activities, a certain level of wear becomes acceptable when no attempt is made to improve the performance of equipment. This then becomes an unnecessary cost burden to operating a plant. If a pump requires repair work every two years, is this satisfactory performance? Of course, this is unacceptable if the mean time between maintenance can be extended to eight years with known technology. Therefore, every effort must be made to develop and implement a plan to increase reliability regardless of the current life that is being achieved. Improvements can always be made. Risk or hazard factors that shorten life must be identified and eliminated.

Ultimate Pump

Each of us is involved with the ultimate pump, our heart, Figure 26. The risk factors that affect performance are cholesterol levels, blood pressure, smoking, lifestyle, and levels of protein constituent homocysteine. The hazard of heart failure is:

$$\text{Hazard or Risk} = f(\text{Age}) + f(\text{Risk Factors}) \quad (4)$$

If we want to reduce the risk of heart failure, the risk factors must be reduced or totally eliminated. The same analogy can be applied to an equipment failure. The risk factors to be eliminated for a pump are improper operation of the pump, process upsets,

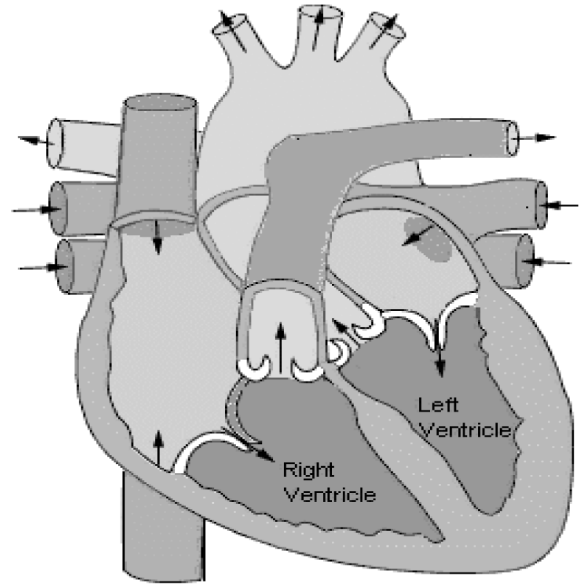

Figure 26. Ultimate Pump—The Human Heart. (Courtesy of Professor Andrew K.S. Jardine, University of Toronto)

cavitation, low net positive suction head (NPSH), loss of cooling, operating too close to the vapor pressure of the fluid sealed, and high levels of vibration. In each case, care must be taken if life is to be extended.

TECHNOLOGIES TO MINIMIZE WEAR

Evolving technologies have been developed to minimize or eliminate the effects of wear while reducing power losses and increasing equipment efficiencies.

Pump Seal Chamber Design

Early ANSI pump designs had a seal chamber referred to as a small cross-section stuffing box bore. This stuffing box design allowed both packing and mechanical seals to be used interchangeably. However, as operating conditions increased, the small bore seal chamber became very restrictive. This resulted in the development of both the large bore and taper bore seal chambers. Figures 27, 28, and 29 illustrate the concept of these chambers.

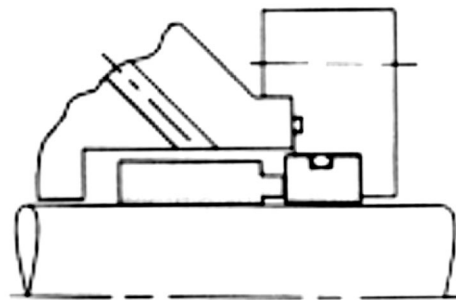

Figure 27. Small Cross-Section ANSI Seal Chamber.

The large bore seal chamber is more than two times larger than the original small cross-section seal chamber. These dimensions allow for a standard ANSI seal to run for 25°F cooler than the original seal chamber. By opening up the back of the seal chamber and providing a slight taper to the bore, the seal chamber will run 40°F cooler than the original seal chamber design. The taper bore seal chamber allowed for easy removal of gas or vapor from building up in the seal area. Abrasives suspended in the fluid represented another problem. Any abrasives in the fluid being pumped would collect in the space at the outside diameter of the seal faces.

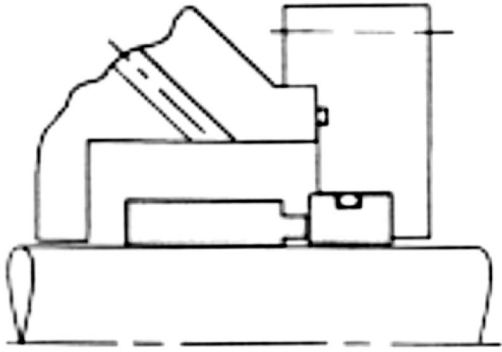

Figure 28. Large Bore ANSI Seal Chamber.

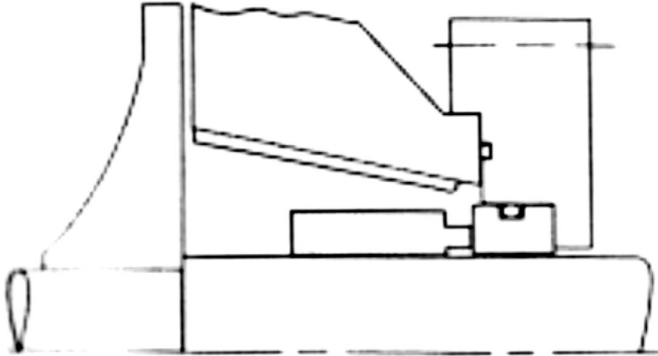

Figure 29. Taper Bore ANSI Seal Chamber.

Allowed to remain in the area, the coarseness and hardness of the abrasive particles began to wear away the bore of the seal chamber in this area. To eliminate this wear problem, axial ridges or vortex modifiers are added to the inside diameter of the seal chamber. This design feature effectively dispersed abrasive particles and eliminated wear to the seal housing.

Variable Speed Pumps

The prime reason to use a variable speed is energy savings. The most common technique used to control flow, pressure, level, etc., is by a control valve. Control valves control by adding friction to the system. The cost of the energy lost is not only the pressure drop across the valve but also includes all the cost of the energy used to create the excess pressure lost across the valve. These costs can be quite substantial. For example, the typical 75 hp pumps waste approximately \$9100 per year (at \$0.045 per kWh) in energy lost across the control valve. Variable speed drives eliminate the need to generate excess pressure because they control by altering the operating speed of the pump, not by inducing friction into the system.

An added benefit is much increased reliability. A properly sized variable speed pump will:

- Generally operate near its best efficiency point (BEP) where loads and forces are the least. Eliminates problems (bearing and seal) caused by low flow or runout operation.
- Operate at speeds much lower than the maximum design speed. Reduces wear and loading, thereby increasing seal and bearing life.
- Control the pump with an optimum diameter impeller. Reduces vibrations caused by the interaction of the impeller and casing cut water. Reduces shaft deflection caused by nonuniform pressure distributions within the casing.

Bloch and Geitner (1994) quantified the above by defining a reliability index (RI), which is the product of the speed reliability factor (F_R), the impeller diameter reliability factor (F_p), and the flow rate capacity factor (F_Q). Figures 30, 31, and 32 are used to determine the individual reliability factors.

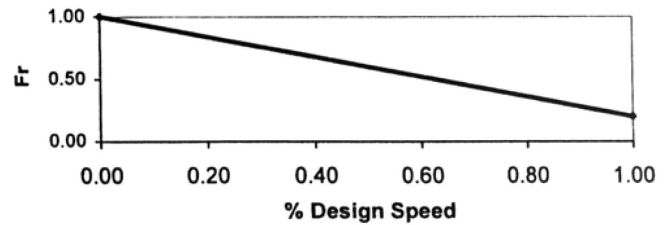

Figure 30. Speed Reliability Factor.

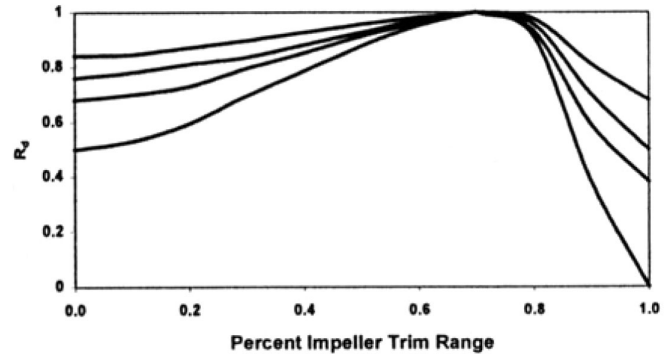

Figure 31. Impeller Diameter Factor.

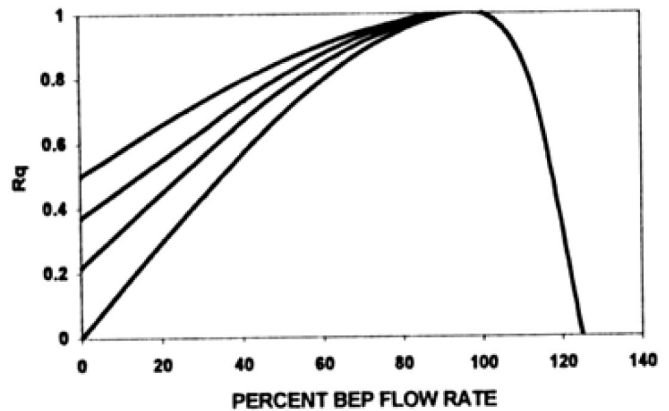

Figure 32. Flow Rate Reliability Factor.

$$RI = F_R \times F_D \times F_Q \quad (5)$$

A way to determine increased reliability is to calculate RI for a pump controlling with a valve in the system and repeat the calculation for a pump sized with a variable speed drive. The ratio of the RI for variable speed over RI for control valve will approximate the expected increase in mean time between preventive maintenance (MTBPM). Fourfold increases in MTBPM have been experienced.

Seals

As relative motion occurs between the seal faces, frictional heat will develop. If this heat is not controlled or removed, seal failure will occur. Seals continue to receive attention in equipment design since it is the most common component listed for equipment failure. Substantial improvements have been made in increasing reliability and life. The key to success is reducing the power losses at the seal faces. This may be accomplished in one of three ways depending on the service conditions for the pump. These methods are:

- New materials of construction for the seal faces,
- New design features for seal faces, and
- Seal face lubrication.

New Materials of Construction

A new family of silicon carbide has made major improvements in seal performance. This is a grouping of graphite loaded silicon carbide materials. The percentage of what is termed free graphite improves lubrication at the seal faces while also improving thermal shock resistance. This would allow a seal to run dry for short periods of time. When run against itself, the pressure velocity, a measure of performance, can be increased by a factor of two. This is possible because of the presence of graphite. This class of materials is providing lower coefficients of friction resulting in reduced temperatures at the seal faces.

This reduction in temperature and the somewhat porous surface allows the liquid being sealed to form good lubricating film at the seal faces to minimize wear.

Seal Design

Seal face designs have been developed to promote seal lubrication to reduce wear. One such design is referred to as laser face. A typical laser face design is shown in Figure 33.

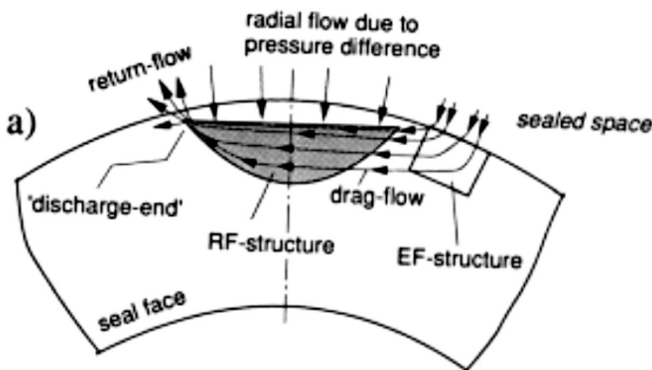

Figure 33. Laser Face Seal Geometry.

In this design, a series of rectangular slots and recesses allow for the fluid sealed to enter the seal face and flow across a portion of the seal face for cooling, and then is pumped back into the seal chamber. The surface features are only microinches deep. The friction at the seal faces can be reduced by as much as 50 percent. The benefits to the user are reduced wear, friction losses, and improved reliability.

Seal Lubrication

Improvements such as laser face technology have made an impact on seal installations where liquid is used to lubricate the seal faces. However, the most significant change in seal technology has been in the area of noncontacting gas lubricated seals for pumps. This design is shown in Figure 34. This concept provides a user with a seal designed to eliminate wear. By using a nitrogen gas barrier, hazardous emissions to the environment are also eliminated. Noncontacting gas lubricated seals operate 92 to 96 percent less power loss than a contacting liquid lubricated seal depending on seal size and operating conditions. Since no frictional heat is generated, a portion of the liquid being pumped does not have to be circulated for cooling. The only heat developed is that of shearing of the barrier gas at the seal faces. This heat is removed by the small amount of gas flow across the seal faces. This results in increased equipment efficiency. Noncontacting gas lubricated seals have become the most efficient sealing systems for users.

For high-pressure applications, a tandem seal may be used provided that the space between the seals is vented to a vapor disposal or recovery system.

For those applications where the fluid being pumped is not hazardous to the environment, a single noncontacting seal may be used. These involved liquid cryogenic gases like nitrogen, oxygen, and argon.

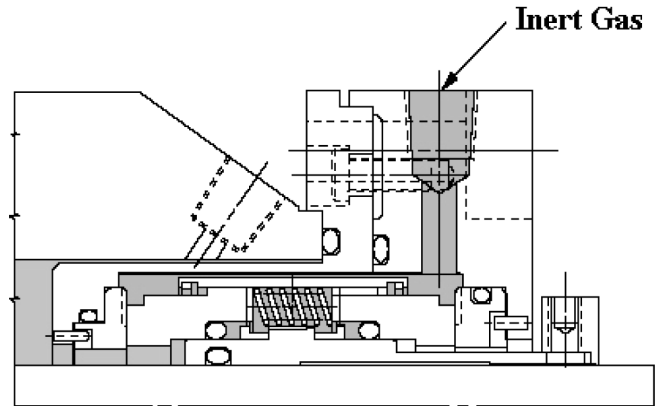

Figure 34. Noncontacting Gas Lubricated Seal Design.

RESULTS ACHIEVED

After the causes for infant and premature failures have been identified and removed, life can then be based on the fluids to be pumped. These types of services may be grouped into the following classes:

- Lubricating fluids
- Aqueous solutions
- Vaporizing fluids
- Cryogenic fluids

Each group or class of fluid has a life for the system that can be extended as new technologies are developed and implemented.

Cryogenic Service

Sealing of liquid oxygen, nitrogen, and argon on over-the-road tanks was identified as a serious problem. Seal life ranged from as short as six weeks to as long as 25 weeks. This involved a fleet of 25 tank trucks in which, during one period when 100 seal failures were removed from service, the face seals were heat checked and discolored. The solution was to provide a design that would eliminate frictional heat. This in turn would eliminate the flashing of the cryogenic gas. The design developed for this application is shown in Figure 35.

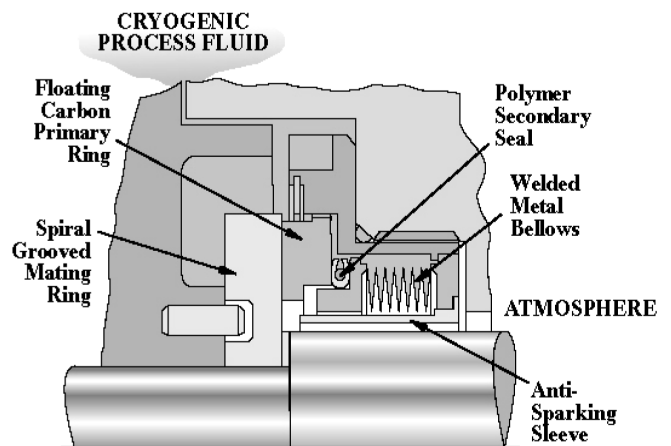

Figure 35. Noncontacting Gas Lubricated Seal for Nonfigure Hazardous Liquefied Gases.

Seal life has now been extended to over six years of service. The resultant savings for the fleet is \$900,000. This exceptional service was achieved through the application of existing technology redesigned for low temperature service.

CONCLUSION

In today's business environment, it is necessary to know how to specify equipment and its component parts for optimum performance. In addition, knowing how to repair equipment is no longer enough. What is required is the knowledge of how to repair equipment for exceptional life. Identifying the cause for short life and the application of existing technology can have a dramatic effect on increasing equipment reliability. This is a team effort that must include plant personnel, the equipment, and component suppliers.

REFERENCES

- Adams, W. V., Erickson, R. B., Needelman, W., and Smith, M. D., 1996, "Field Investigation of Bearing Housing Oil Cleanliness," *Proceedings of the Thirteenth International Pump Users Symposium*, Turbomachinery Laboratory, Texas A&M University, College Station, Texas, pp. 71-79.
- API Standard 610, 1995, "Centrifugal Pumps for Petroleum, Heavy Duty Chemical and Gas Industry Services," Eighth Edition, American Petroleum Institute, Washington, D.C.
- API Standard 682, 1994, "Shaft Sealing Systems for Centrifugal and Rotary Pumps," American Petroleum Institute, Washington, D.C.
- API RP 686, 1996, "Machinery Installation and Installation Design," American Petroleum Institute, Washington, D.C.
- Bloch, H. P. and Geitner, F. K., 1994, *Introduction to Machinery Reliability and Assessment*, Houston, Texas: Gulf Publishing, pp. 99-103.
- Lorenc, J. A., 1991, "Changes in Pump Vibration Levels Caused by the Misalignment of Different Style Couplings," *Proceedings of the Eighth International Pump Users Symposium*, Turbomachinery Laboratory, Texas A&M University, College Station, Texas, pp. 63-70.
- Wallace, N. M., Redpath, D., and Netzel, J. P., 2000, "Toward Reduced Pump Operating Costs," *Proceedings of the Seventeenth International Pump Users Symposium*, Turbomachinery Laboratory, Texas A&M University, College Station, Texas, pp. 171-186.

BIBLIOGRAPHY

- Netzel, J. P. and Voigt, J., 2001, "Reducing Life-Cycle Costs for Pumps Handling Cryogenic Fluids," *Proceedings of the Eighteenth International Pump Users Symposium*, Turbomachinery Laboratory, Texas A&M University, College Station, Texas, pp. 1-4.
- Netzel, J. P., Redpath, D., and Wallace, N. M., 2001, "Toward Reduced Pump Operating Costs, Part Two—Avoiding Premature Failures," *Proceedings of the Eighteenth International Pump Users Symposium*, Turbomachinery Laboratory, Texas A&M University, College Station, Texas, pp. 135-146.
- Wallace, N. M. and Miller, H. K., 1994, "The Development of Low Friction, Low Leakage Mechanical Seals Using Laser Technology," *Proceedings of the Eleventh International Pump Users Symposium*, Turbomachinery Laboratory, Texas A&M University, College Station, Texas, pp. 19-27.
- Wasser, J. R., Sailor, R., and Warner, G., 1994, "Design and Development of Gas Lubricated Seals for Pumps," *Proceedings of the Eleventh International Pump Users Symposium*, Turbomachinery Laboratory, Texas A&M University, College Station, Texas, pp. 63-67.