

# THE EFFECTS OF VALVE DYNAMICS ON RECIPROCATING PUMP RELIABILITY

by

**Stephen M. Price**

Senior Project Engineer

**Donald R. Smith**

Senior Project Leader

**James D. Tison**

Senior Staff Engineer

Engineering Dynamics Incorporated

San Antonio, Texas



*Stephen M. Price is a Senior Project Engineer for Engineering Dynamics Incorporated. He is actively involved in solving a variety of problems in systems that have experienced failures due to dynamic phenomenon. He has had field and analytical experience solving problems with reciprocating and rotating machinery, along with structural and acoustical problems. Additionally, Mr. Price has been involved in development of multiple channel data acquisition and monitoring hardware and software for critical environments. He has presented and published several papers in the areas of signal processing, finite element analysis, acoustics, and reciprocating pumps. Mr. Price, a registered Professional Engineer and a member of ASME, has a B.S. (Mechanical Engineering) degree from Mississippi State University and an M.S. (Mechanical Engineering) degree from Purdue University.*

*ing hardware and software for critical environments. He has presented and published several papers in the areas of signal processing, finite element analysis, acoustics, and reciprocating pumps. Mr. Price, a registered Professional Engineer and a member of ASME, has a B.S. (Mechanical Engineering) degree from Mississippi State University and an M.S. (Mechanical Engineering) degree from Purdue University.*



*Donald R. Smith is a Senior Project Leader at Engineering Dynamics Incorporated (EDI). For the past 25 years, he has been active in the field engineering services, specializing in the analysis of vibration, pulsation, and noise problems with rotating and reciprocating equipment. He has authored and presented several technical papers. Prior to joining EDI, he worked at Southwest Research Institute for 15 years as a Senior Research Scientist where he was also involved in troubleshooting and failure analysis of piping and machinery. Mr. Smith received his B.S. (Physics) from Trinity University (1969). He is a member of ASME and the Vibration Institute.*

*involved in troubleshooting and failure analysis of piping and machinery. Mr. Smith received his B.S. (Physics) from Trinity University (1969). He is a member of ASME and the Vibration Institute.*



*James D. (Jim) Tison is a Senior Staff Engineer at Engineering Dynamics Incorporated. He has been extensively involved in field measurements and computer modelling of rotating and reciprocating equipment of over 17 years. For the past 12 years, his work has been primarily related to development and improvement of software for the simulation of pulsation in compressor and pump piping systems, and overall responsibility*

*for acoustic and mechanical design studies of reciprocating compressor and pump piping systems. He is a member of ASME and holds B.S. and M.S. degrees (Mechanical Engineering) from the University of Florida.*

## ABSTRACT

Compared to leading edge technologies such as high speed turbomachinery, reciprocating pumps may appear to be a simple technology: A reciprocating plunger causes liquid to be drawn from a low pressure manifold through the suction check valves, and expelled into a high pressure manifold through the discharge check valves. However, the interaction of flow, valve dynamics, and the acoustics of the pump and piping system can generate high amplitude pressure pulsation, causing severe vibration and reliability problems in some systems. The effects of improperly operating valves, and the successful resolution of such problems with valve design modifications are examined.

Since the pump valves are operated by the action of the fluid, valve components (including the springs, valve body, valve disc shape, and sealing surfaces, etc.) must be carefully selected to ensure that the valves open and close at the appropriate times. Problems associated with valve dynamics include over pressure spikes at the opening of discharge valves, under pressure spikes at the opening of the suction valves, high noise levels, and excessive wear of valve components.

Severe over pressure spikes have been known to cause fatigue failures of pump working barrels, connecting rods, bearings, and even drive-train components. Under pressure spikes can cause cavitation that can also lead to plunger and valve failures, due to pitting damage. High level valve noise is usually indicative of severe impacts associated with the opening and closing of the valves. Impacts at the valve closing are sometimes referred to as valve hammer and can result in damage to the sealing surfaces. Impacts at the valve opening, which may be identified by damage to the back side of the valve disc, are due to the over pressure and under pressure spikes which can result in fatigue failures of the components. Excessive valve wear can also be experienced when the valve disc material is not suitable for the pumping conditions.

The use of field data coupled with a computer model to analyze the valve dynamics will be presented. Using this tool, the effect of various valve modifications such as changes in sealing surfaces, valve lift, spring preload, and spring stiffness can be observed. Instrumentation and data analysis techniques to evaluate these problems will also be discussed. The effects of

modifications to valves (including changes in lift, spring preload, spring construction and stiffness, valve disc geometries, etc.) will be examined using data from actual systems.

## OVERVIEW OF PUMP VALVE RELATED PROBLEMS

Many problems with reciprocating pumps have been shown to be due to improper valve operation. In an optimum system, the suction and discharge valves would open and close at the precise instant to facilitate the suction or discharge stroke. However, the plunger can change velocity faster than the valves can respond, resulting in "valve lag." If a discharge valve lags on opening, higher than normal pressures are created in the pump cylinder (working barrel) since the plunger continues to compress the liquid in the cylinder until the valve opens. When the valve finally opens, the pressure in the cylinder is higher than the discharge line pressure. The rapid buildup and release of this pressure at the beginning of the discharge stroke is called an over pressure spike. Similarly, if the suction valve lags on opening, the pressure in the cylinder will be rapidly reduced until the suction valve opens. This rapid reduction and return of pressure at the beginning of the suction stroke is called an under pressure spike. If the pressure falls below the vapor pressure, cavitation can result. As the suction pressure returns to normal, vapor bubbles formed during cavitation will collapse, creating high amplitude "cavitation spikes." Even with properly operating valves, lag of a few degrees is inevitable. However, factors such as spring preload, stiffness, valve disc mass, valve lift, and pump speed can significantly increase the valve lag.

Pressure time data taken in the working barrel from a triplex pump that had an over pressure spike problem are shown in Figure 1. The over pressure spikes act on the plungers and the resulting forces are transmitted to the rods, crankshaft, bearings and frame. This additional dynamic pressure therefore increases the load induced stresses on the power end and the liquid end components and can contribute to fatigue failure of these parts.

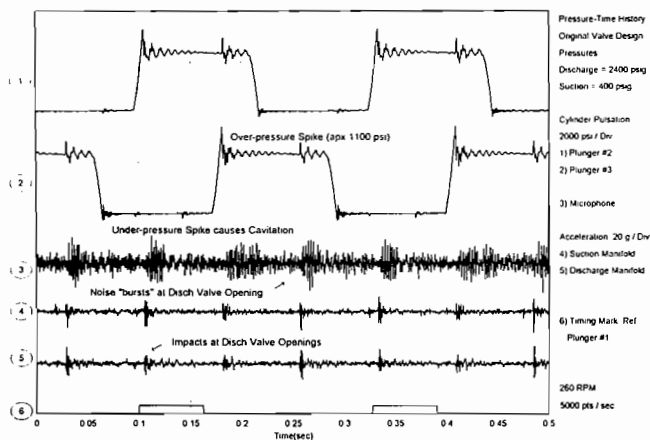

Figure 1. Pressure Time Histories—Triplex Pump With Over Pressure Spike.

The over pressure spike is the resultant of several combined effects including:

- Viscous adhesion (sticktion) of the valves to the seat (which depends upon sealing area, surface finish, disc flexibility, and fluid properties)
- Plunger side/line side dynamic pressures
- Differential area (unbalanced valve area)

- Acceleration of valve disc (due to changes in running speed)
- Spring preload and stiffness
- Valve mass

Data obtained from numerous field measurements by EDI have indicated that, when significant over pressure spikes occur, they are most often due primarily to the sticktion effect. In addition to potentially causing damaging forces and cavitation, the sticktion effect creates a reduced pressure area near the center of the sealing surface. At the reduced pressure location, cavitation may result on both the suction and discharge valves. The resulting cavitation pits on the discs and seats are usually concentrated near the center of the sealing surface. These pits are often mistaken for foreign object damage (Figure 2).

Typical Valve Damage Due to Sticktion  
Induced Cavitation

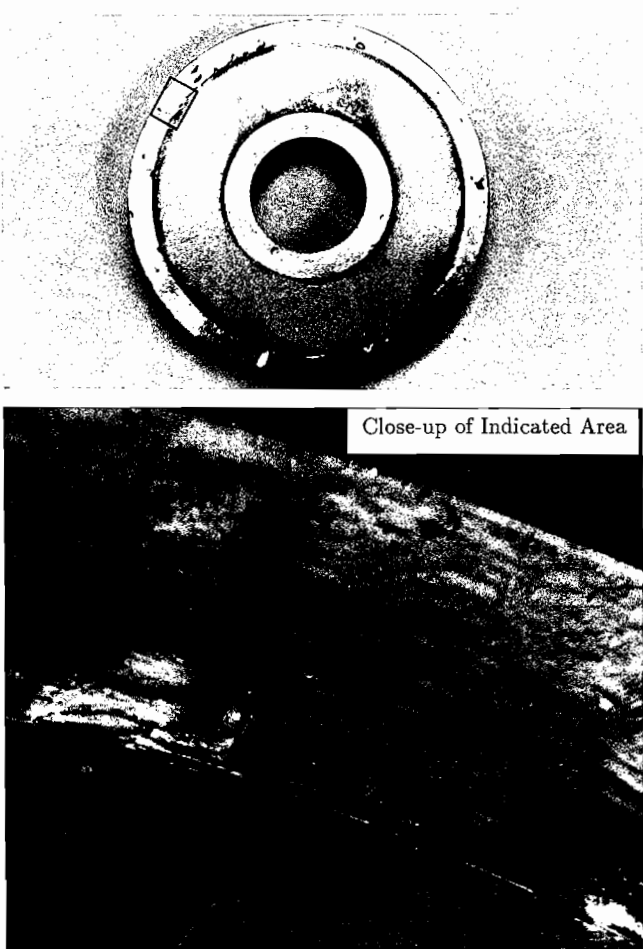

Figure 2. Typical Stricktion Induced Valve Disc Damage.

## FIELD TESTING OF RECIPROCATING PUMPS

Field data are the primary diagnostic tools for analysis of pump valve behavior. The data can ultimately be used to provide the basis upon which analytical calculations depend. However, the data must be of a high quality to be useful.

A general technique of field data acquisition has been developed that has been used extensively to obtain the required data for use in analyzing valve problems. Instrumentation, acquisition software, and data analysis techniques have been combined

to deliver the desired characteristics. Each of these aspects are discussed in the following sections.

### Instrumentation

Several different types of instruments are needed to quantify pump behavior. A typical installation on a vertical triplex pump is illustrated in Figure 3.

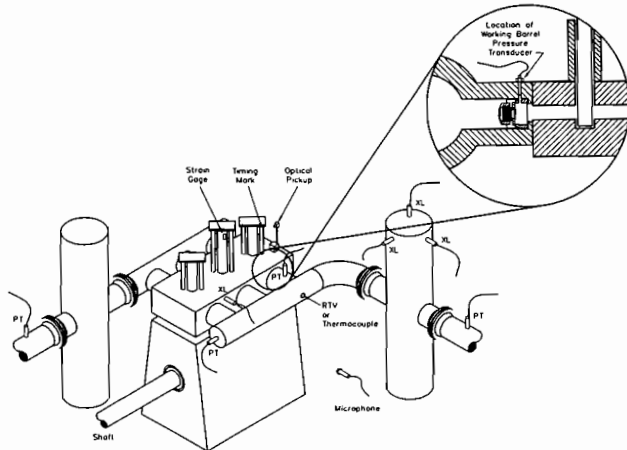

Figure 3. Typical Reciprocating Pump Instrumentation.

**Pressure Transducers (PT).** Pressure time data should be obtained in one or more pump cylinders (working barrels), in the suction and discharge manifolds, and at locations in the piping where high vibration levels occur. These data are usually obtained with dynamic pressure transducers. Sensitivities of 5.0 to 10 mV/psi are usually the best choices for pulsation measurements in the piping and manifolds. Since the change in cylinder pressure from suction to discharge pressure fluctuates over a wide range (typically 3000 psi), low sensitivity (1.0 mV/psi) transducers should be used for measurements in the cylinders. Static pressure measurements are sometimes needed to evaluate the system with regard to cavitation, or to quantify certain process conditions that may be important to pump operation. Strain-gage type transducers are most often used for this purpose. These transducers require more elaborate signal conditioning and calibration than piezo-electric transducers. The static transducers can also be used for dynamic measurements, if the conditioning amplifiers have sufficient frequency response.

**Accelerometers (XL).** With appropriate signal conditioning, accelerometers can be used to measure low-frequency piping vibration. However, it is important to measure high-frequency energy, too. Cavitation, over pressure spikes, and other "impact" energies often result in high-frequency vibration in the pump. Accelerometers mounted on the pump manifolds are useful for measuring this energy. These acceleration data can be used to identify problems with specific cylinders or valves. To obtain the required high frequency response, the accelerometers should be rigidly mounted (i.e., not attached with magnets).

**Strain Gages.** Where failures have occurred, it is sometimes useful to install strain gages to measure the strain levels at the location of the failures. Although these instruments require a good deal of effort to install, the resulting data are usually worth the additional effort. Acquiring strain data on reciprocating or rotating components may require that the data be telemetered (although some success has been achieved with direct wiring of gages to reciprocating parts).

Strain gages attached to the plunger can also be used to infer cylinder pressures when it is not possible to install cylinder

pressure transducers. It should be noted, however, that the data can be distorted due to excitation of plunger lateral natural frequencies, friction, and inertial effects.

**Microphones.** Some problems are discovered because operations personnel hear atypical noises emanating from the pump. Microphones installed in the near-field can be useful in correlating perceived noise with other phenomenon that might be occurring.

**Thermocouples/RTDs.** For problems involving cavitation, it is often important to measure the fluid temperature at the pump. Thermocouples and RTDs can be easily installed to provide this information.

**Timing Mark.** Much of the data acquired will be analyzed in the time domain. A timing mark is required to help identify specific portions of the pumping cycle and to identify improperly operating valves. Magnetic pickups, optical pickups, or proximity probes can be used to provide a once per revolution pulse. The pickups can be installed to sense a keyway or reflective tape on an exposed shaft. An optical sensor is often used to sense the passage of a reflective tape on the side rods (Figure 3).

**Tape Recorder.** A multichannel FM or digital recorder should be used to ensure that data can be recorded for later playback. This capability is invaluable for capturing data from a startup, a shutdown, and "trip" situations. The recorder should be adjusted to provide at least a 5.0 kHz bandwidth.

### Data Acquisition

The data acquisition system should be capable of acquiring data in both the time and frequency domains. Time domain data are used to evaluate the operation of the pump (i.e., valve lag, pressure buildup, etc.). Frequency domain data are usually used to evaluate system resonances. Given the ability of portable computers to manipulate and store information, time domain data are most efficiently acquired using analog-to-digital (A/D) conversion hardware coupled with a computer.

Most reciprocating pumps operate at speeds below 300 rpm, which would seem to indicate that only low-frequency data are required. However, the rapid pressure buildup and reactant flow "bursts" from each cylinder can generate energy to frequencies of 3000 Hz or more. Therefore, sampling rates as high as 6000 Hz per channel may be required. A typical test will usually involve 10 to 15 channels of data that should all be acquired simultaneously for comparison of data. Since most A/D boards multiplex their inputs, the sampling rate requirements for 15 channels of data could be as high as 90,000 Hz. (Multiplexing is a technique whereby a single A/D converter can be used for many channels. This technique reduces the expense and complexity of the A/D hardware with only minor tradeoffs in acquisition speed and quality.) Typically, data will be acquired for periods of one sec up to one minute. The acquisition system could be required to manipulate as much as 10 Mbytes of data (15 channels at 6000 Hz sampling rate per channel, one minute of acquisition) per captured event.

### Data Analysis

Analysis of the acquired data can be a time consuming task. Acquisition software capabilities can lessen the burden of manipulating the large amounts of data that result. A system has been developed at EDI that has been shown to be effective at acquiring the necessary data. System capabilities are outlined below.

**Channel Management.** A facility is provided to manage and display transducer sensitivities, descriptive text, and channel numbers.

**Acquisition Control.** Parameters such as sampling rates, and acquisition time are easily controlled.

**Acquisition Triggers.** Acquisition of data are sometimes desired only when specific events occur. Typical events include a pulse from the timing mark, a peak—peak dynamic signal level or a certain static pressure. A pretrigger (beginning acquisition *before* the trigger occurs) is provided to add flexibility to the triggering.

**Filtering.** Sometimes, the signals include unwanted “noise.” Digital filter algorithms are used to remove the unwanted noise. Low-pass, high-pass, band-pass, and band-stop filtering have all been required.

**Data Display.** Some or all traces may be presented simultaneously on the “page.” The orientation and placement of each trace is easily adjustable. Capabilities for detailed documentation and annotation of data (to note specific test conditions, time and date, etc.) are also provided. Hard copy may be obtained by a variety of devices, including both raster and vector devices.

**Data Storage/Retrieval.** Acquired data may be stored for later recall. Facilities are available to import/export data from/to other software packages. This capability allows further manipulation of data (e.g., to compute a single channel of principal strain data from a rosette of three strain gages).

### SOLVING PUMP-VALVE RELATED PROBLEMS

Using the previously described field data acquisition techniques, many different types of pump and system problems have been addressed. In some cases, it is necessary to utilize analytical capabilities to fully understand a problem. Case histories of actual pump installation are described in the following sections.

#### *Pump Component Failures Due to Over pressure Spikes*

Several triplex pumps experienced drive train and fluid-end component failures that, when the pumps were inspected, appeared to be the result of excessive loads. When operating, high amplitude impact noises could be heard, as if internal components were “knocking.” Ground-borne vibration could be felt by personnel standing near to the pump. Typically, valve life was short. After only a few hours of operation, the valve discs and/or seats became pitted as if foreign object damage had occurred (Figure 2). Often times, the valve disc or seat developed a series of pits at the center of the sealing surface that joined together to form a ring that appeared to have been machined into the surface.

One of the triplex pumps was instrumented as described earlier with pressure transducers in the pump cylinders and manifolds, and with accelerometers mounted on the pump manifold. A near-field microphone was also installed. Initial data (Figure 1) showed that high amplitude (40 percent to 50 percent) over pressure spikes were occurring at the beginning of the discharge stroke.

Cavitation due to under pressure spikes was also observed at the instant the suction valves opened. Sound measurements showed noise bursts at the instant of discharge valves opening (Figure 1). Accelerometers mounted on the pump manifold also showed impact energy which correlated with the opening of the discharge valves, and sometimes with the opening of a suction valve.

The over pressure spikes generated impact forces. Knocking noises occurred as the impact force traveled through the power end. These impact forces were apparently responsible for the damage that had been experienced. In the suction side, cavitation resulted when the under pressure spike caused the suction pressure to fall below the vapor pressure. It was thought that the delay in opening of the suction and discharge valves could be due to sticktion.

As discussed earlier, sticktion is a phenomenon that produces a force that holds the valve disc onto the seat and retards the opening of the valves. The magnitude of the sticktion force is a

function of the width of the sealing surface of the valve disc. A wide seal will produce a much higher force than a narrow seal. Therefore, to reduce the sticktion force, the valve *sealing* surface area must be reduced (considering only the potential for sticktion, the ideal seal surface would be a knife edge). However, if the valve *seating* surface area is too small, impact stresses in the valve disc and seat will be too high, resulting in valve damage. The authors have determined that a groove pattern cut into the valve disc or seat may be used to reduce the sealing area, which can sometimes reduce the sticktion force without significantly affecting the seating area. A typical groove pattern for a disc is shown in Figure 4.

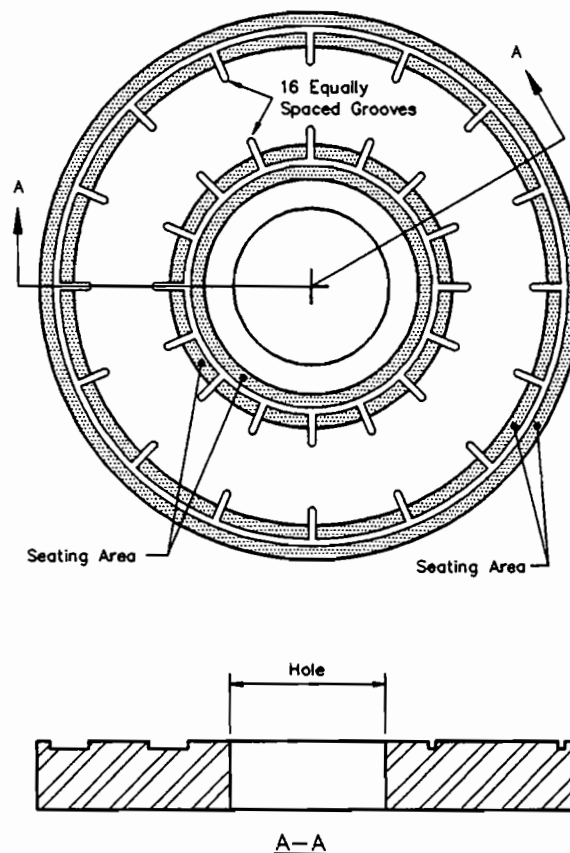

Figure 4. Groove Pattern to Reduce Sticktion.

A set of valve seats were machined with the groove pattern shown in Figure 4 and were installed in a pump. It was decided to machine the grooves into the valve seat rather than the disc, because it was felt that the modification would be more permanent. When the pump was started, knocking noises were no longer present and personnel standing near the pump also indicated that the ground-borne vibration could no longer be felt. Data acquired in the pump cylinder showed that the over pressure spike had been nearly eliminated (Figure 5). Cavitation spikes in the suction side were reduced. Impact energy (acceleration) measured at the pump manifolds was also significantly reduced.

Flowrates with the modified valve seats were 6.5 percent higher than with the original valve seats. This initially surprising result was found to be due to a decrease in valve lag from 16.4 to 11.7 degrees. Discharge valve lag causes “backflow” from the discharge into the working barrel at the beginning of the suction stroke. Similarly, suction valve lag causes backflow from the

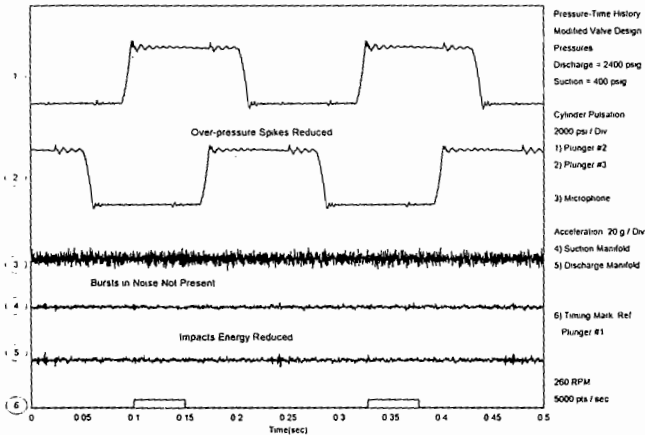

Figure 5. Pressure Time Histories—Over Pressure Spike Reduced.

cylinder back into the suction as the discharge stroke begins. The suction and discharge valve lag reduce volumetric efficiency—i.e., a decrease in flow.

The pumps were operated for approximately one year with the valve seat modification. No additional failures were reported. However, when the valves were inspected, the valve discs appeared to be “forging” themselves into the valve seat. Although the valves were operating satisfactorily, it was felt that the effective groove pattern was reduced. Therefore, the discs were replaced with new valve discs. Even though the one year valve life was much improved over the original design, alternative valve disc materials are currently being investigated to extend their lives.

Use of Valve Dynamics Analysis

It has been shown to be possible to reduce the over/under pressure spikes by cutting grooves in the valve. It is also possible to alter other valve design parameters (i.e., fluid viscosity, valve disc mass, spring rates, etc.) to affect over/under pressure spikes. While the specific modifications may be arrived at by trial and error, it can be more effective to use an analytical tool (valve dynamics analysis) to evaluate the effects of different designs before installing them. As will be demonstrated, field data, combined with analytical analysis, can be used to achieve better results in actual operation.

Valve Dynamics Simulation Techniques

A computer based dynamic simulation technique has been used to determine the sensitivity of the valve displacement time history and the cylinder pressure time history to the various pump and valve parameters. The valve motion and cylinder pressure are determined by numerical integration of the governing differential equation of motion. The discontinuities due to valve impact on the seat or stop are handled by integrating between “smooth” portions of the solution using restarts with new initial conditions to switch to the next piece-wise smooth portion of the solution.

A sketch showing pertinent parameters of the pump cylinder-valve model is given in Figure 6. A plunger (piston) of diameter  $D$  is driven by a crankshaft of radius,  $r$ , and a connecting rod of length  $l$ . The clearance volume of liquid changes with time, as does its pressure. The valve discs are assumed to be rigid bodies, and the impacts are assumed to be perfectly plastic (no rebound). The valve disc mass is acted upon by the forces of the spring  $K$ , and by two damping components,  $C^1$  and  $C^2$ , which are coefficients for damping force proportional to the first and

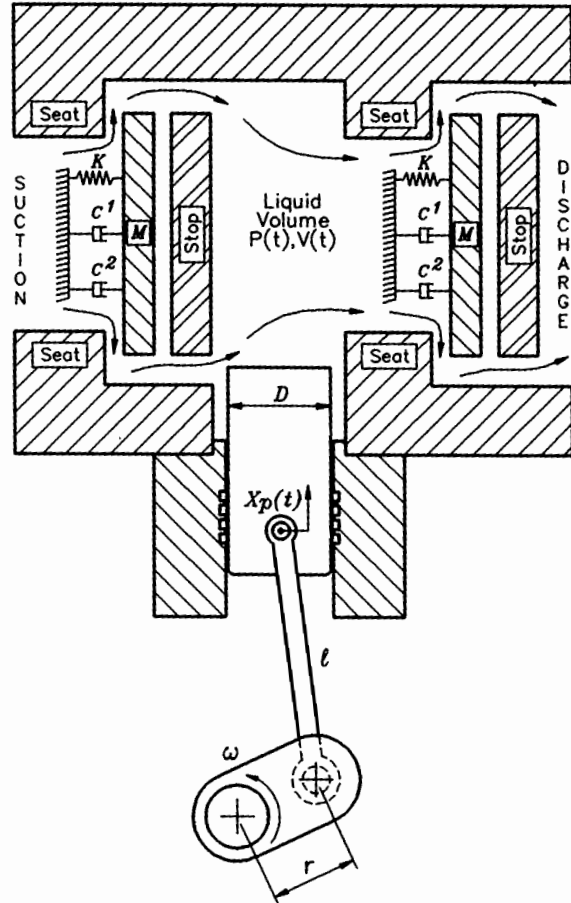

Figure 6. Pump Cylinder Valve Model Parameters.

second powers of the velocity of the valve disc. A pressure loss factor for the valve is determined based on empirical data, with the volumetric flow through the valve.

$$Q = A \sqrt{\frac{2\Delta P}{K\rho}} \tag{1}$$

where:

- Q = volumetric flow through valve
- A = time variable area
- $\Delta P$  = pressure drop across valve
- K = valve loss coefficient
- $\rho$  = fluid mass density

The governing differential equations for the system are:

$$\frac{dP_{cyl}}{dt} = \left( Q_{sv} - Q_{dv} + \left( \dot{x}_p \cdot \frac{\pi D^2}{4} \right) \right) / C_v \tag{2}$$

$$M_{sv}\ddot{x}_{sv} + C_{sv}^1\dot{x}_{sv} + C_{sv}^2|\dot{x}_{sv}|\dot{x}_{sv} + K_{sv}x_{sv} = \Sigma F_{sv} \tag{3}$$

$$M_{dv}\ddot{x}_{dv} + C_{dv}^1\dot{x}_{dv} + C_{dv}^2|\dot{x}_{dv}|\dot{x}_{dv} + K_{dv}x_{dv} = \Sigma F_{dv} \tag{4}$$

where:



- $C_v$  = volume compliance  
 $B$  = liquid effective bulk modulus  
 $\dot{x}_p$  = velocity of plunger  
 $D$  = diameter of plunger  
 $Q_{SV}$  = volumetric flow rate — suction  
 $Q_{DV}$  = volumetric flow rate — discharge  
 $P_{cyl}$  = (uniform) pressure in clearance volume  
 $M_{SV}$  = disc mass—suction valve  
 $M_{DV}$  = disc mass—discharge valve  
 $K_{SV}$  = spring rate—suction valve  
 $K_{DV}$  = spring rate—discharge valve  
 $C_{SV}^1$  = damping coefficient 1—suction valve  
 $C_{DV}^1$  = damping coefficient 1—discharge valve  
 $C_{SV}^2$  = damping coefficient 2—suction valve  
 $C_{DV}^2$  = damping coefficient 2—discharge valve  
 $x_{SV}$  = displacement of suction valve from seat  
 $x_{DV}$  = displacement of discharge valve from seat  
 with subscript SV specifying the suction valve,  
 and subscript DV specifying the discharge valve.

The right-hand side terms  $\Sigma F_{SV}$  and  $\Sigma F_{DV}$  represent forces acting on the suction and discharge valve discs due to fluid pressure, and include:

- Viscous adhesive (sticktion) force acting on valve due to velocity of separation of disc from the seat.
- Differential pressure across valve acting on effective area of valve

The time domain solution proceeds with assumed initial conditions at time  $t = 0$ . The initial plunger position corresponds to the maximum chamber volume, so that the plunger begins compressing the liquid in the clearance volume. The differential equations are integrated numerically in time with all of the pertinent pressure, displacements, flows and forces calculated at each time step. Cylinder pressure and valve displacement and velocity values as a function of crank angle are written to disk files for post-processing.

Sticktion effects can be modeled by considering the case of two parallel surfaces immersed in a liquid (Figure 7). The viscous adhesive force is [1]:

$$F_s = - \frac{\mu b^3}{(y + e_0)^3} \cdot \frac{de}{dt} \cdot L, \quad (5)$$

where:

- $F_s$  = sticktion force acting on seat  
 $\mu$  = liquid absolute viscosity  
 $b$  = width of seat  
 $e$  = film thickness  
 $e_0$  = initial film thickness  
 $y$  = displacement of valve disc from seat  
 $L$  = circumferential length of seat.

This effective sticktion force is due to the pressure profile created over the width of the seat as the fluid fills the void created by the separation velocity. This effect is also referred to as the Bernoulli effect.

From this equation, it can be seen that the valve seat width  $b$  has a strong influence on the sticktion force. Therefore, this dimension is an extremely important design parameter of the valve assembly. The sticktion force is also proportional to the fluid viscosity, and the force is strongly dependent on the initial effective film thickness,  $e_0$ , which is influenced by the surface

finish of the disc and seat, and the degree to which the surfaces are in intimate contact. The,  $e_0$ , parameter can change as the valve wears and with pressure differential. Different valve disc materials may conform more or less to the seat, changing the effective  $e_0$  even though the design may be dimensionally identical. Therefore, it is extremely difficult in practice to evaluate  $e_0$  accurately, making model normalization using measured data a prerequisite to obtaining valid simulation results. Note also that since the separation velocity appears in the equation, it would be expected that higher pump speeds would result in higher sticktion induced pressure overspikes. Field data have indeed shown this to be the case.

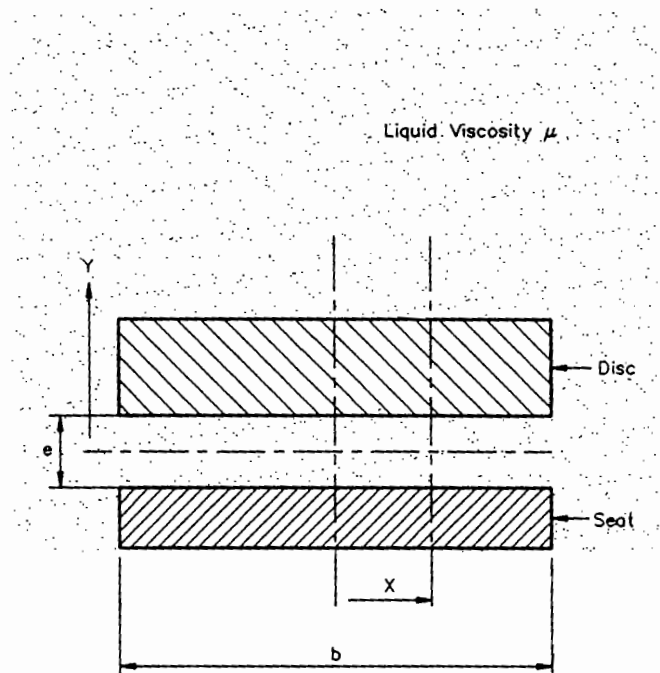

Figure 7. Model for Sticktion for Immersed Surfaces.

#### Coupling Analysis with Field Data

A crude oil pump system in operation for a short period of time experienced fatigue failures of small bore piping (vents and drains) attached to the main pipe. Due to the critical service of the pump, a field study was done to determine the cause(s) of the piping failures. Instrumentation was installed similar to that shown in Figure 3. After the piping was repaired, strain gages were attached at the locations of the failures and the pump was operated. The data indicated that the failures were the result of excessive vibration of the piping "stubs" at their structural natural frequencies (which were in excess of 200 Hz). This fact seemed unusual, since there is normally little energy generated by the pump at these frequencies. Further data acquisition and analysis showed that the energy exciting the resonant vibration was not from pulsation, but was an impact energy which was being mechanically transmitted from the pumps through the piping and support structures.

The source of the high frequency energy was determined to be impact forces generated by high amplitude over pressure spikes in the cylinders (Figure 8). One obvious solution to eliminate the piping failures was to add braces to reduce the differential vibration between the vent/drain and the main piping; however, there were many similar fittings in the piping system which made it impractical to brace all of the fittings. Therefore, it was

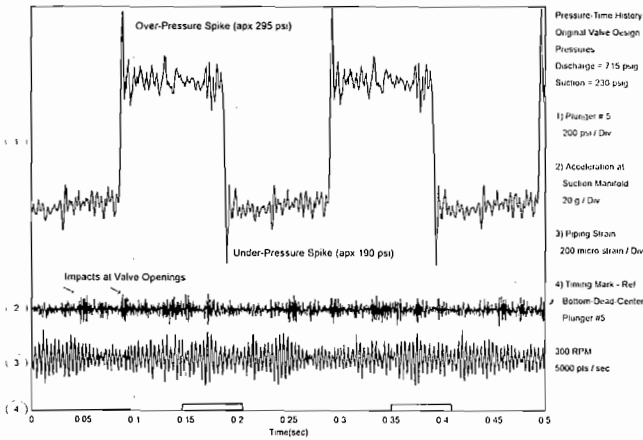

Figure 8. Comparisons of Over Pressure Spike, Impact Acceleration, and Piping Strain.

decided to reduce the over pressure spikes by modifying the valves, which, it was hoped, would also reduce the high-frequency vibration of the stub piping.

Initially, the groove pattern shown in Figure 4 was cut into the valve discs. When the pump was operated, reductions in over/under pressure spike amplitudes were not significant. Rather than proceed on a “trial and error” basis, it was decided to utilize the valve dynamic analysis tools to predict a groove pattern that would be effective.

Numerous valve designs were analyzed. A sketch of the valve disc is shown in Figure 9. The pump characteristics are outlined in the table below.

Parameter	Value
Operating Speed	150 & 300 rpm
Liquid Density	61 lb/ft <sup>3</sup>
Liquid Viscosity	30 µreyns
Stroke	7.0 in
Bore	4.75 in
Suction Pressure	230 psia
Discharge Pressure	715 psia
Suction and Discharge Valve Disc Weights	1.7 lbs
Suction and Discharge Spring Constant	112 lb/in
Suction and Discharge Valve Lift	0.46 in
Valve Spring Preload	54 lbs
Valve Disc Material	Delrin

The results of the computer analysis are presented in time domain graphs of the plunger pressure, suction valve displacement and velocity, and discharge valve displacement and velocity (Figure 10). The simulation results at 300 rpm predict an over pressure spike of approximately 285 psi (1000 psi spike minus 715 psi static discharge pressure). Under pressure spikes of 175 psi caused the pressure in the cylinder to fall to the vapor pressure, initiating cavitation spikes. The valve displacement graphs indicate that the valve discs would impact the valve stops during opening. This agreed with the damage that had been experienced on the back side of the valve discs and the broken springs which occurred after a short operating time.

For reduced speed operation of 150 rpm, the peak pressure was reduced to approximately 825 psia which is equivalent to an over pressure of 175 psi. The under pressure spike was computed to be 70 psi above vapor pressure. Field data obtained for these two cases correlated well with the simulation results (the 300 rpm case is shown in Figure 8).

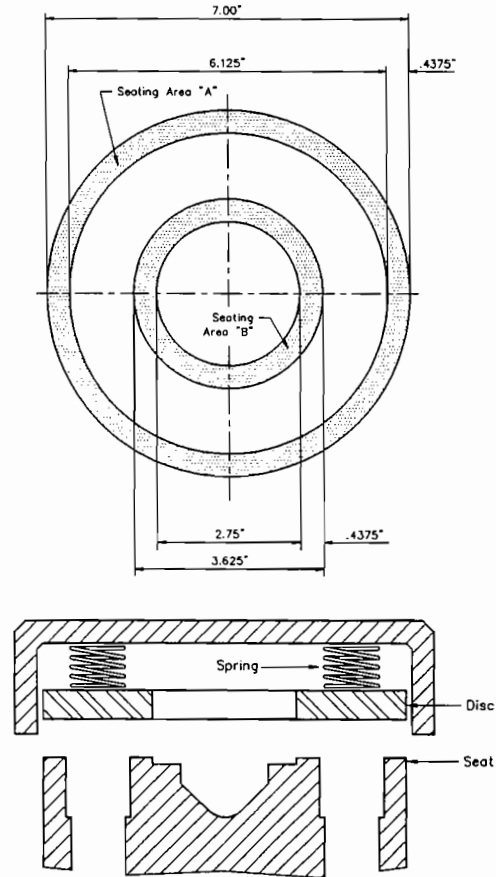

Figure 9. Typical Pump Valve Disc and Seat.

To reduce the over pressure spike, it was proposed that the discharge valve discs be modified, as shown in Figure 11. To reduce the under pressure spike, the suction valves were similarly modified. The concept of the modification was to reduce the width *b* of the sealing surface which, as shown in Equation (5), directly influences the sticktion force by its value cubed. The results of the computer simulation of these modification are shown in Figure 12. Both the over pressure and under pressure spikes were significantly reduced at 300 rpm. In addition, the valve vertical displacement (lift) was no longer hard against the stop. This would reduce the impact force against the valve stop and would reduce the damage to the springs. Similar improvements were obtained at 150 rpm.

Field data acquired after the valves were installed are shown in Figure 13. As shown in the pressure time histories, the amplitudes of the over pressure and under pressure spikes were significantly reduced. Strain gage data also showed a significant decrease in strain amplitudes at the stub piping. A summary of the measured and computed over/under pressure spike amplitudes at 300 rpm is shown in the table below.

Data	Original Design		Modified Design	
	Over-pressure	Under-pressure	Over-pressure	Under-pressure
Field	295 psi	190 psi	120 psi	100 psi
Analytical	285 psi	175 psi	96 psi	88 psi

Other designs (Figure 14) were analyzed that showed a further reduction in over pressure spike amplitude. Although the computer analyses indicated that additional improvement could be

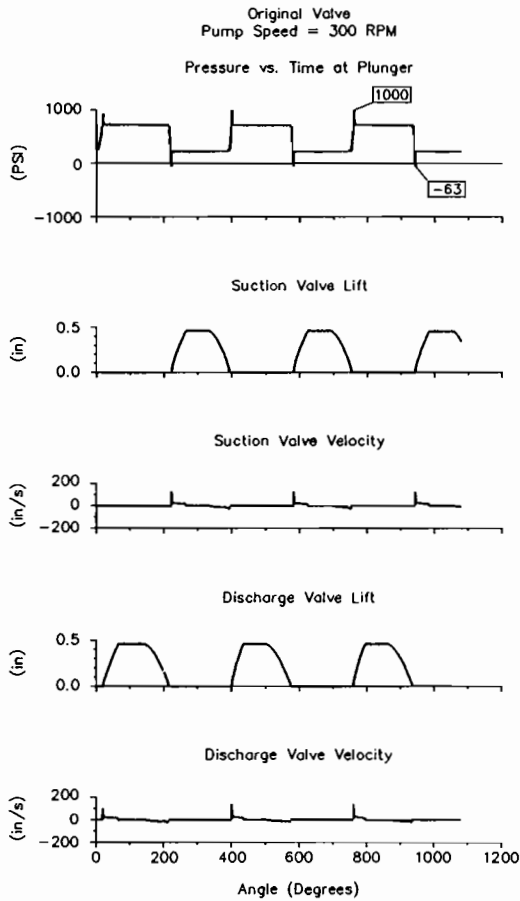

Figure 10. Computed Valve Dynamic Time Histories—Original Design.

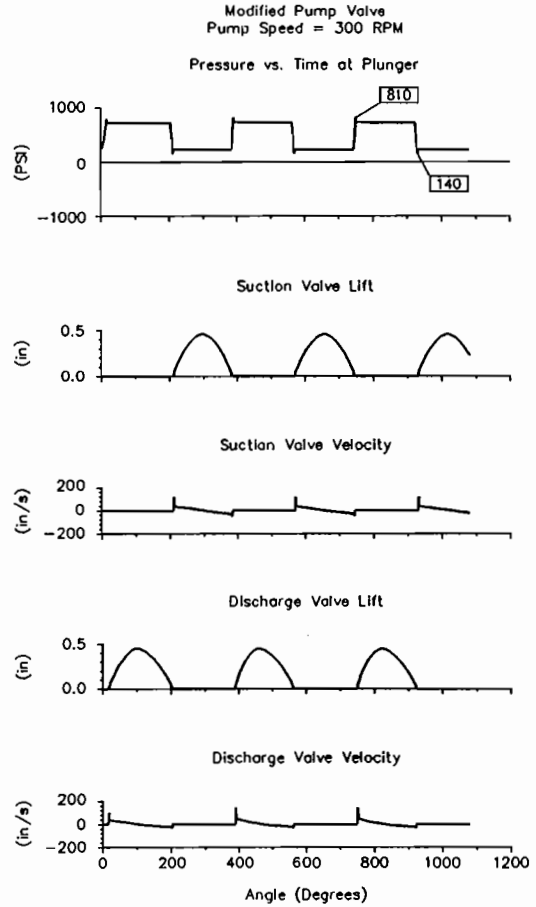

Figure 12. Computed Valve Dynamic Time Histories—Modified Design.

obtained with the other groove patterns, these designs were not tested, because there was concern that the remaining seat area was insufficient to provide adequate load bearing for the pressures experienced. Additionally, the analytical and field data showed that at some point, further reductions in seat area did not

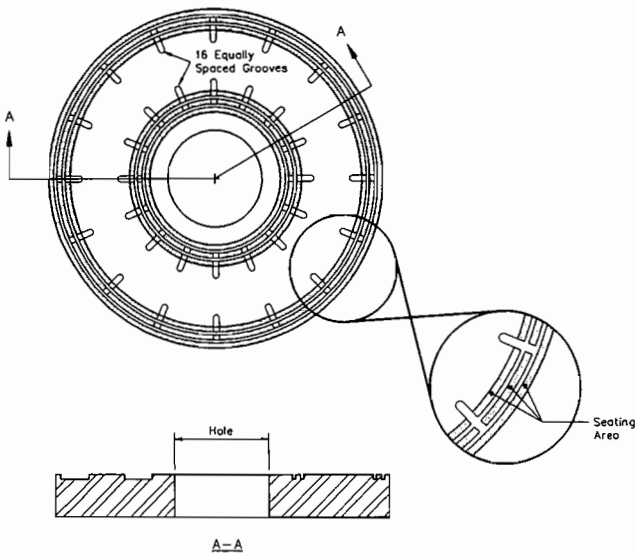

Figure 11. Double-Row Groove Pattern.

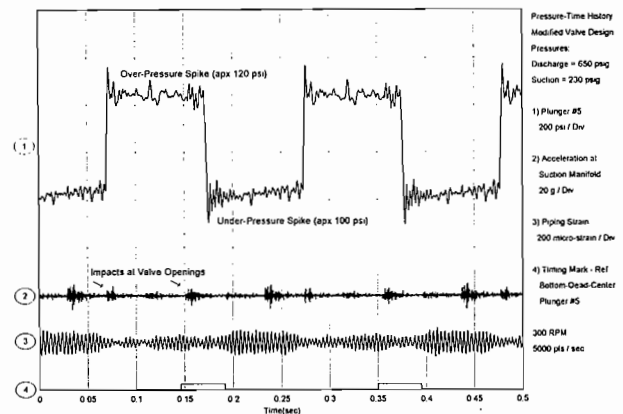

Figure 13. Over Pressure Spike, Impact Acceleration, and Piping Strain after Valve Modification.

cause further reductions in over pressure spike amplitudes, indicating that other effects were predominating the over pressure spike generation. Therefore, another type of valve would probably need to be considered to provide further improvements.

*Operational and Design Parameters Affecting Sticktion*

Other pumps were tested that had similar over/under pressure spike problems due to sticktion forces. As has been shown,



TUTORIAL ON THE EFFECTS OF VALVE DYNAMICS ON RECIPROCATING PUMP RELIABILITY

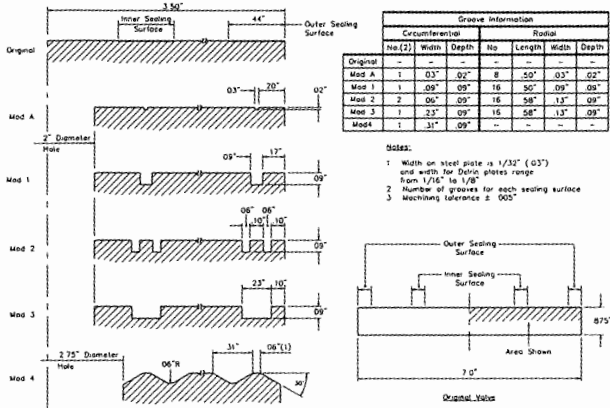

Figure 14. Other Valve Disc/Seat Groove Patterns.

cutting grooves into the valve disc or seat will not always eliminate the spikes. Several tests were conducted which showed that pump operational parameters and valve design parameters other than seat width could also affect the sticktion forces.

Valve Disc Material

A pump with flat, dual-ported steel valve discs was experiencing over pressure spikes of approximately 50 percent of discharge pressure. It was decided by the user to change valve disc material (for reasons unrelated to the over pressure spike) to PEEK plastic. No changes were made in the valve disc or seat designs. With the PEEK valve discs, over pressure spikes were reduced to 16 per cent of developed pressure.

Cutting grooves into the valve disc further reduced over pressure spike amplitudes to 11 percent, which was not as dramatic a reduction as had been previously experienced at some other installations.

Computer analysis showed that the reduction in mass of the PEEK valve disc could cause a reduction in over pressure spikes, but by an amount smaller than what was actually experienced. One possibility for the discrepancy is that the valve disc was probably not in complete contact with the seat, due to the increased flexibility of the PEEK material (Figure 15). The imperfect contact would have effectively reduced the sealing

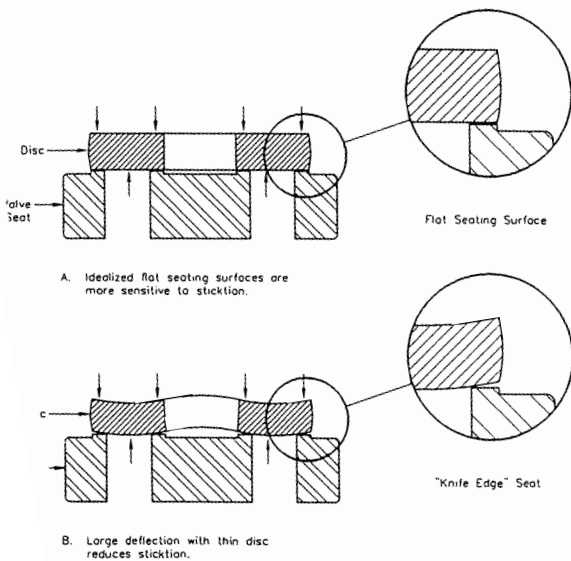

Imperfect Valve Seating Due to Disc Flexibility.

area, which in turn reduced the sticktion effect. This phenomenon would also account for the grooves being less effective.

Pump Speed

Theory predicts that the valve disc velocity also affects the magnitude of the sticktion force. Since velocity of the disc is directly related to pump speed, the sticktion forces and resulting over/under pressure spikes should be higher. When data were acquired on variable speed pumps, this was indeed what was found. For example, the over pressure spike amplitudes were increased from 20 percent to 45 percent of discharge pressure when the pump speed was increased from 150 to 300 rpm.

Fluid Differences

It was found that virtually identical pump valve designs operating with similar pressures and speeds, but different fluids, could have dramatically different sticktion characteristics. Field data has shown that sticktion forces are greater for fluids having higher viscosity and molecular cohesion. (Molecular cohesion is the phenomenon that gives rise to viscosity. For Newtonian liquids, viscosity is essentially the resistance to shear caused by a velocity gradient. The amount of resistance depends both on the molecular cohesion and the shear. Without the presence of a velocity gradient, the molecular cohesion alone results in a "stickiness" [2].) For instance, a pump that operated with water experienced much less over pressure than a similar design operating with amine (a substance somewhat like automotive antifreeze).

CONCLUSIONS

Extensive field testing of reciprocating pumps that have experienced failures in the working barrels, valve and piping have shown that the valve behavior strongly influences the vibration and failures. Over pressure spikes have previously been attributed to area ratio, valve disc mass, and preload. Perhaps a more important factor is sticktion (Bernoulli effect), which is primarily related to seat area. Fluid effects such as viscosity and molecular cohesion, pump speed, valve disc and seat surface finish, and valve disc stiffness also affect sticktion, but to a lesser degree.

Sticktion delays the valve opening which results in over pressure spikes, valve disc impacts at valve opening, and local damage (cavitation pits) to valve seats. High amplitude impact noises are often an identifying characteristic of over pressure spike problems. These over pressure spikes can also cause excessive loads to be transmitted to pump components, which can result in drive train component failures and working barrel failures. In some cases, the high frequency mechanical impact energy was shown to be structurally transmitted throughout the pump and piping system exciting structural resonances that ultimately caused piping failures.

In the design phase, it is useful to perform detailed valve dynamic analyses to assist with valve geometry selection. When problems occur, use of instrumentation and data analysis hardware/software will lead to an understanding of pump problems. This information can be used alone, or combined with valve dynamical analyses to produce solutions to the pump problems. The groove pattern on the valve discs and seats has been shown to be effective in reducing the sticktion effects and associated problems.

REFERENCES

1. Streeter, V. L., and Wylie, E. B., *Fluid Mechanics*, Seventh Edition, New York, New York: McGraw-Hill Book Company (1979).

2. Bauer, F., "The Influence of Liquids on Compressor Valves," International Compressor Engineering Conference at Purdue University, West Lafayette, Indiana (1990).

#### ACKNOWLEDGEMENTS

The authors wish to thank the staff of EDI and especially Mark Broom for his assistance in producing many of the figures.