

The Effect of Foundation Piers on the Natural Frequencies of a Vertically Mounted Sewage Pump in Resonance with Vane Pass Excitations

Paul A. Boyadjis:

- *Mechanical Solutions, Inc. – Principal Engineer and Manager of Turbomachinery Analysis*
- *He has over 29 years of diverse experience in pump analysis/design/test. Specialized in complex 3D FEA modeling of pump casings & rotors.*
- *Lead analytical engineer for major compressor and pump manufacturers such as Ingersoll-Rand, Ingersoll-Dresser Pump, and Flowserve Corporation.*
- *BS and MS in Mechanical Engineering from Lehigh University.*
- *Member of the API Machinery Standards Committee and a Standards Partner of the Hydraulic Institute.*
- *Co-Author Pump Vibration Chapter, McGraw-Hill Pump Handbook*

The Effect of Foundation Piers on the Natural Frequencies of a Vertically Mounted Sewage Pump in Resonance with Vane Pass Excitations

27th International Pump Users Symposium

George R. Brown Convention Center

Houston, TX

September 24 - 27, 2012

By:

Paul A. Boyadjis

Manager of Engineering Analysis

Mechanical Solutions, Inc.

Whippany, NJ 07981 USA

Tel: (973) 326-9920

www.mechsol.com

Background Information

- ◆ A VFD driven sewage pump with a long drive-shaft mounted on large vertical concrete piers was originally analyzed for natural frequency prediction using FEA techniques as required by the specification.

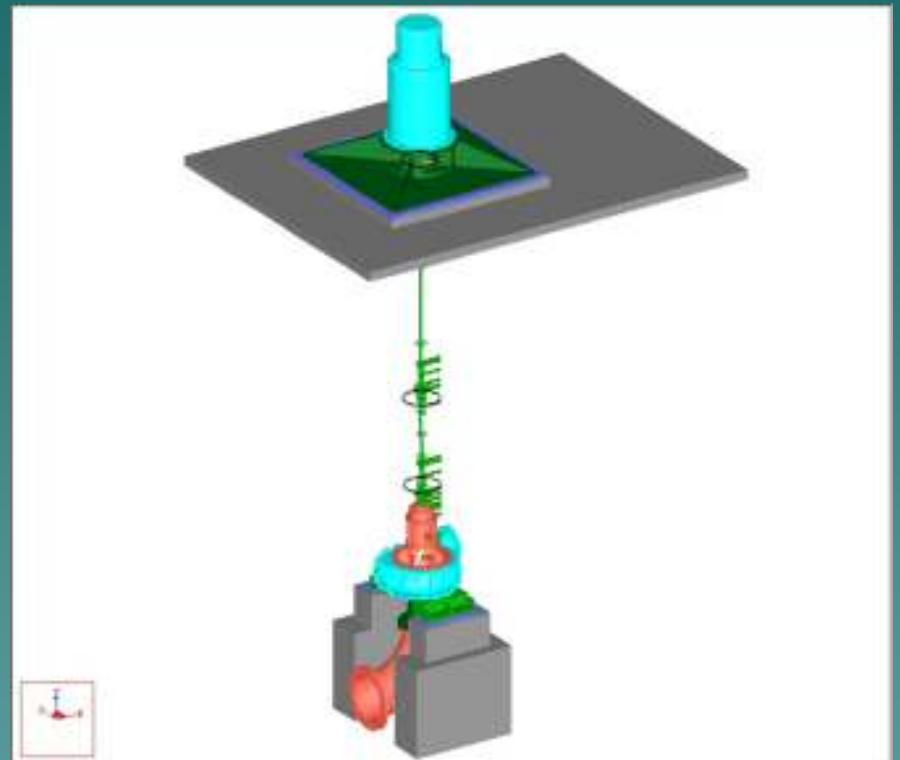

Pump Operating Conditions

- ◆ The operating speed range of the pump is 552 rpm to 595 rpm (9.20 Hz to 9.92 Hz) and is controlled by a VFD.
- ◆ The pump flow rate is 35 MGD (24300 GPM) and develops 193 Ft TDH at 1500 HP.
- ◆ The pump impeller has four (4) vanes and is made from cast steel. The OD is approximately 44 inches. Vane pass excitation range is from 36.8 Hz to 39.7 Hz.

Background Information

- ◆ Preliminary analysis found that the entire pump volute casing mounted on two 10 ft. high vertical concrete piers predicted rocking modes that fell within 4x running speed of the pump (36.8 Hz-39.7 Hz) and the $\pm 20\%$ separation margin range of 29.4 Hz to 47.6 Hz

Background Information

Original FEA Results

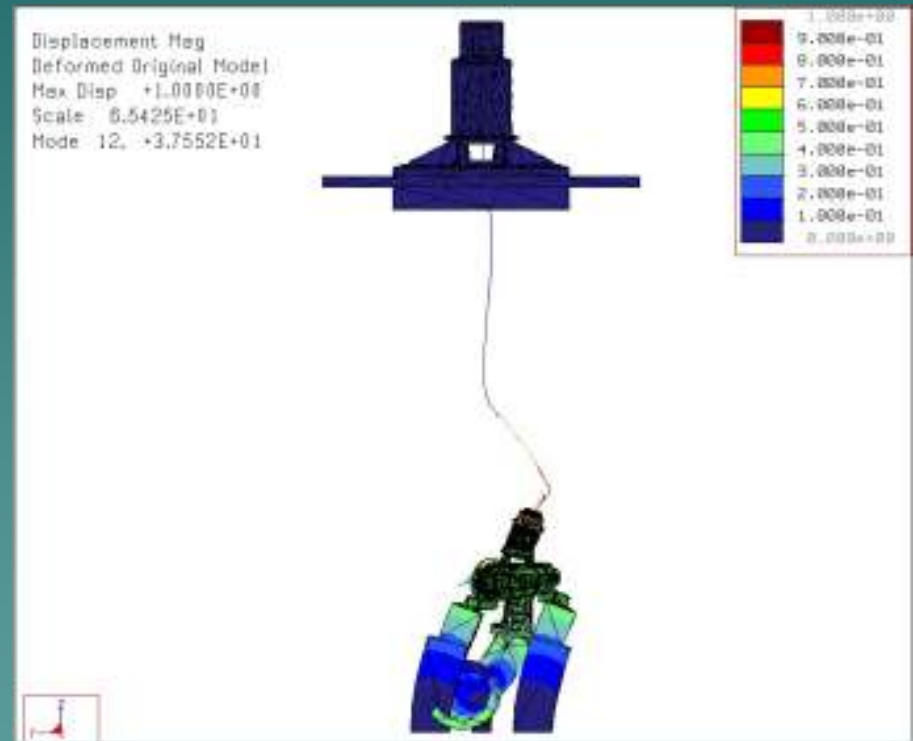
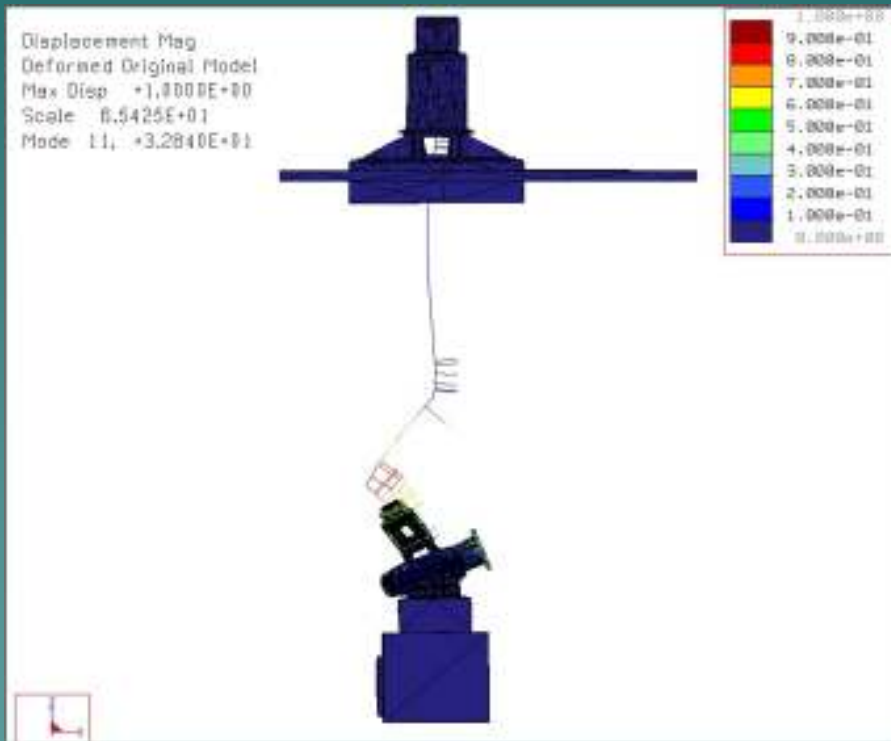

Casing Rocking Modes @ 32.8 Hz and 37.6 Hz

Figure 1

Background Information

- ◆ Modifications to the model were made prior to the pump's installation which consisted of supports for the suction and discharge nozzles as well as joining the two vertical piers on the discharge side to form a horseshoe support. These modifications were predicted to raise the offending casing rocking mode natural frequencies to 20% above 4x running speed (vane pass) to ~ 48 Hz.

Background Information

Original Modified FEA Results

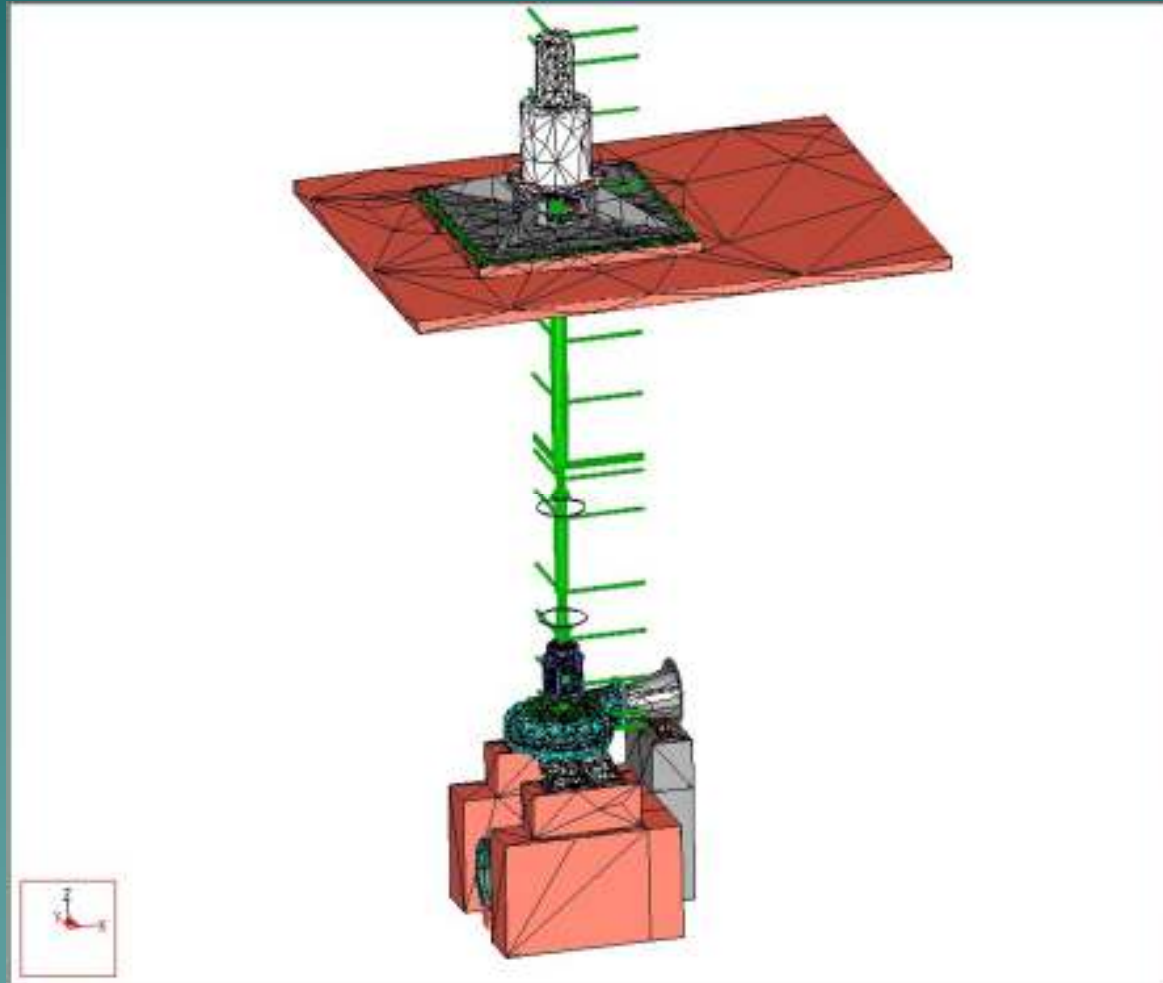

Figure 2

Background Information

Original Modified FEA Results

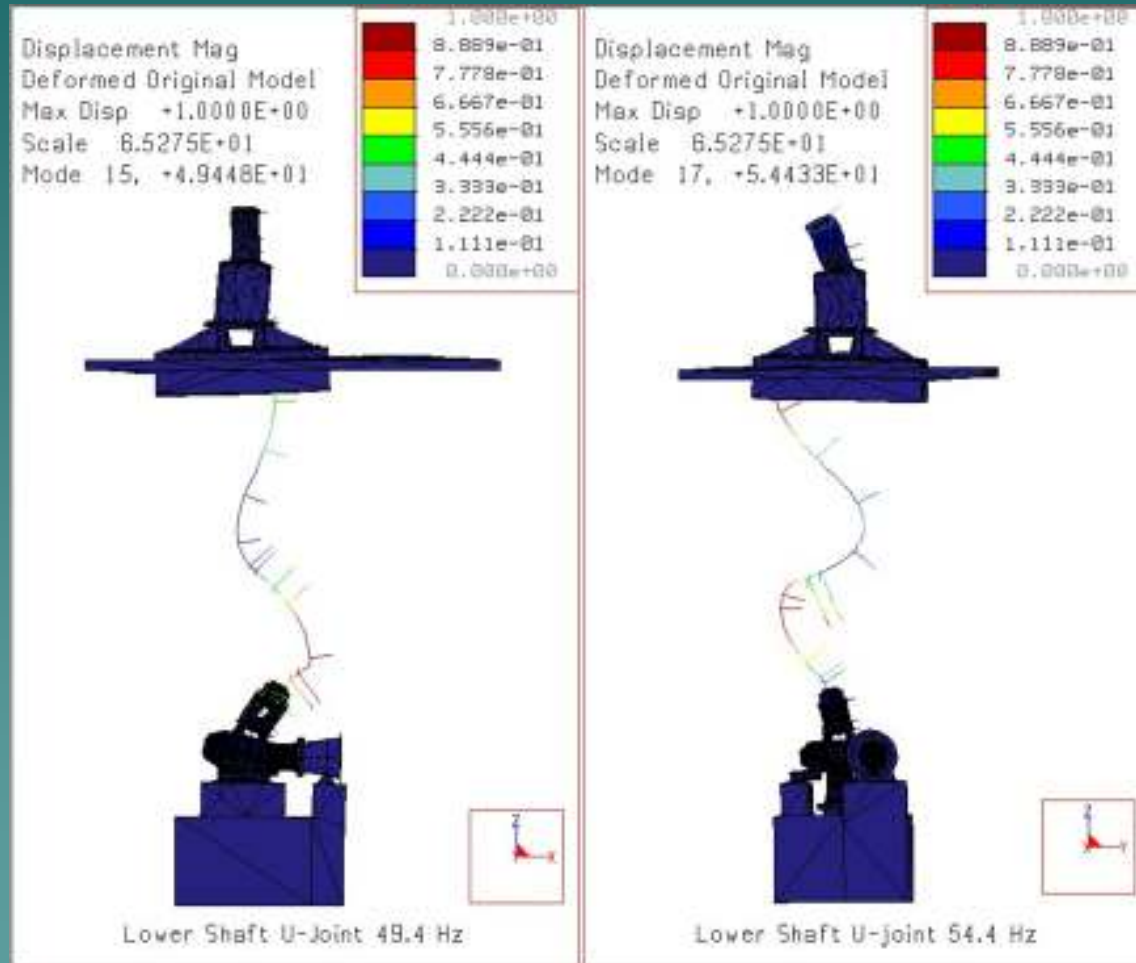

Figure 3

Problem Statement

- ◆ When the pump was finally installed, high vibrations were being measured on the pump bearing tower of 0.6 in/s RMS at 4x running speed (vane pass). ***But Why? Hadn't the analysis provided guidance to avoid this???***
- ◆ The task now was to determine the source of the vibration via field trouble shooting methods and propose a suitable solution without costly trial and error field fixes using the existing FEA model.

Analysis Methods

- ◆ Perform detailed modal and operating deflection shape (ODS) with multi-channel data acquisition equipment.
- ◆ Hammer impact modal testing as well as using an accelerometer attached to a shaft rider stick on the pump shaft during operation were used to determine the natural frequencies of the pump.

Initial Observations

- ◆ The installed pump was mounted on two vertical piers that were not connected together as recommended.
- ◆ The suction inlet was not supported as recommended.
- ◆ The discharge was supported but its pier was mostly imbedded in one of the vertical piers.
- ◆ The pump discharge was rotated approximately 5 degrees.

Field Testing Measurement Points

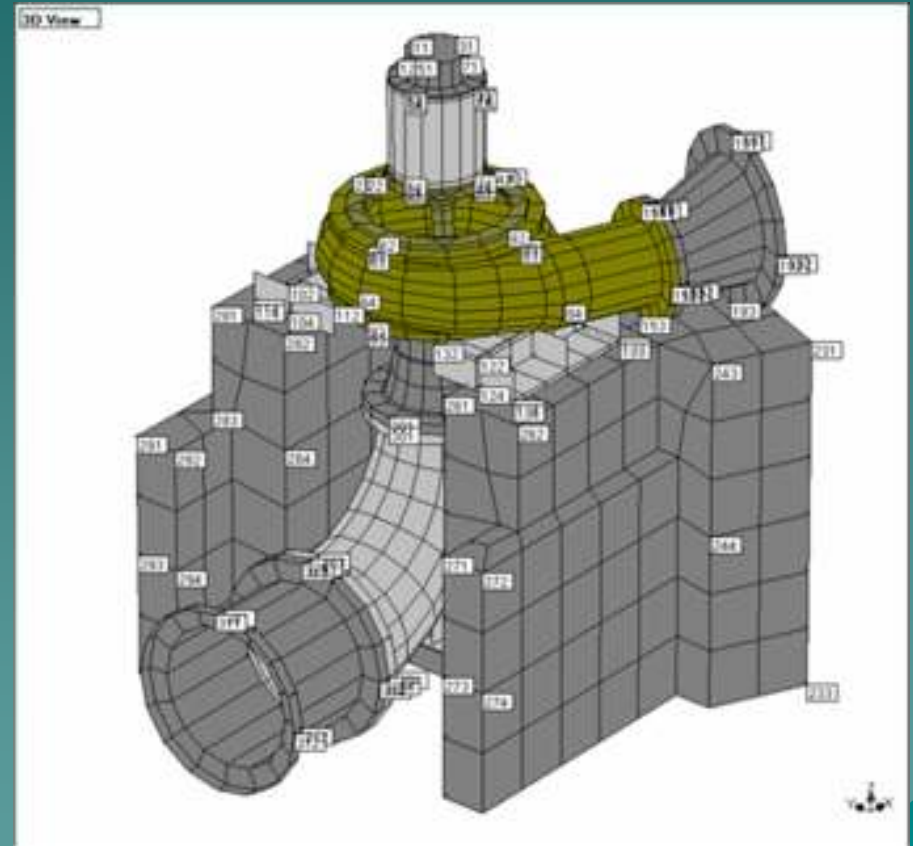
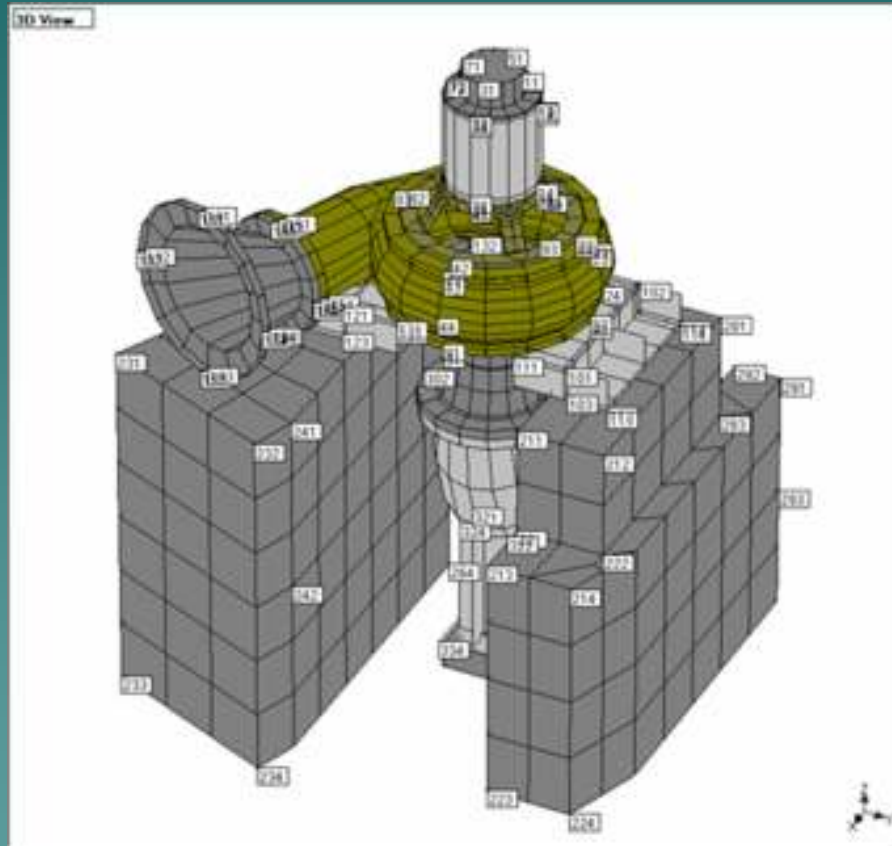

Over 500 vibration measurement/ direction using tri-axial accelerometers

Figure 4

Hammer Impact Modal Response at Bearing Tower

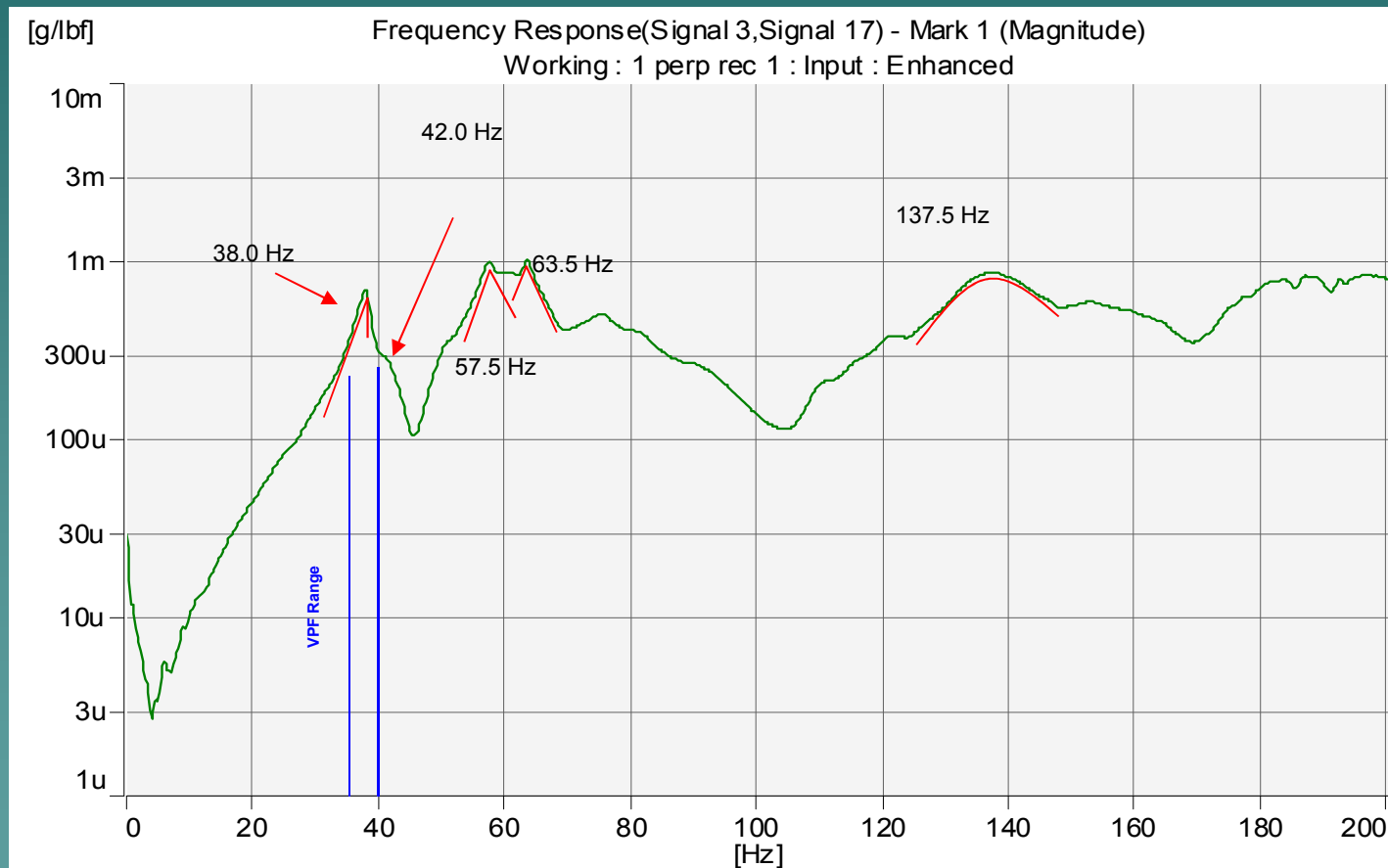

Figure 5

Modal Test Animation at 38 Hz

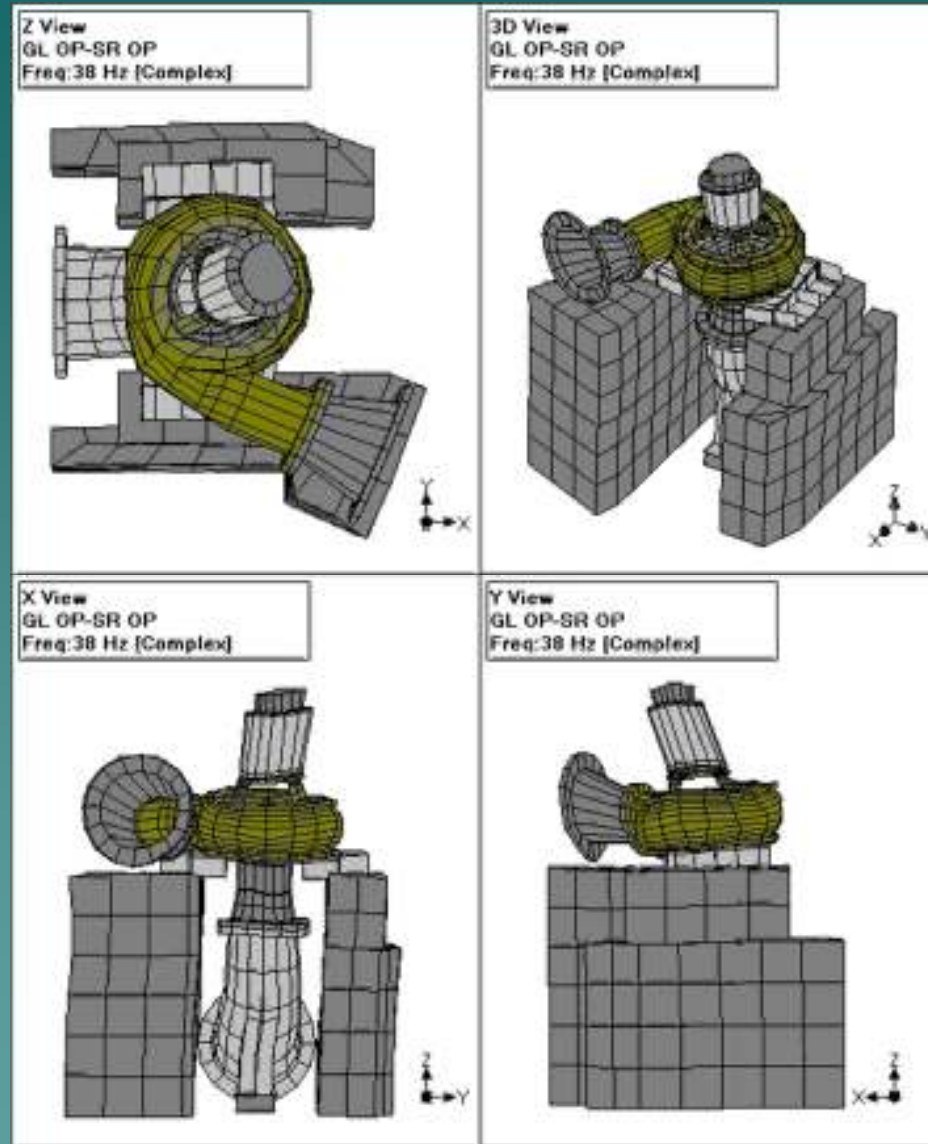

Figure 6

Modal Test Animation at 42 Hz

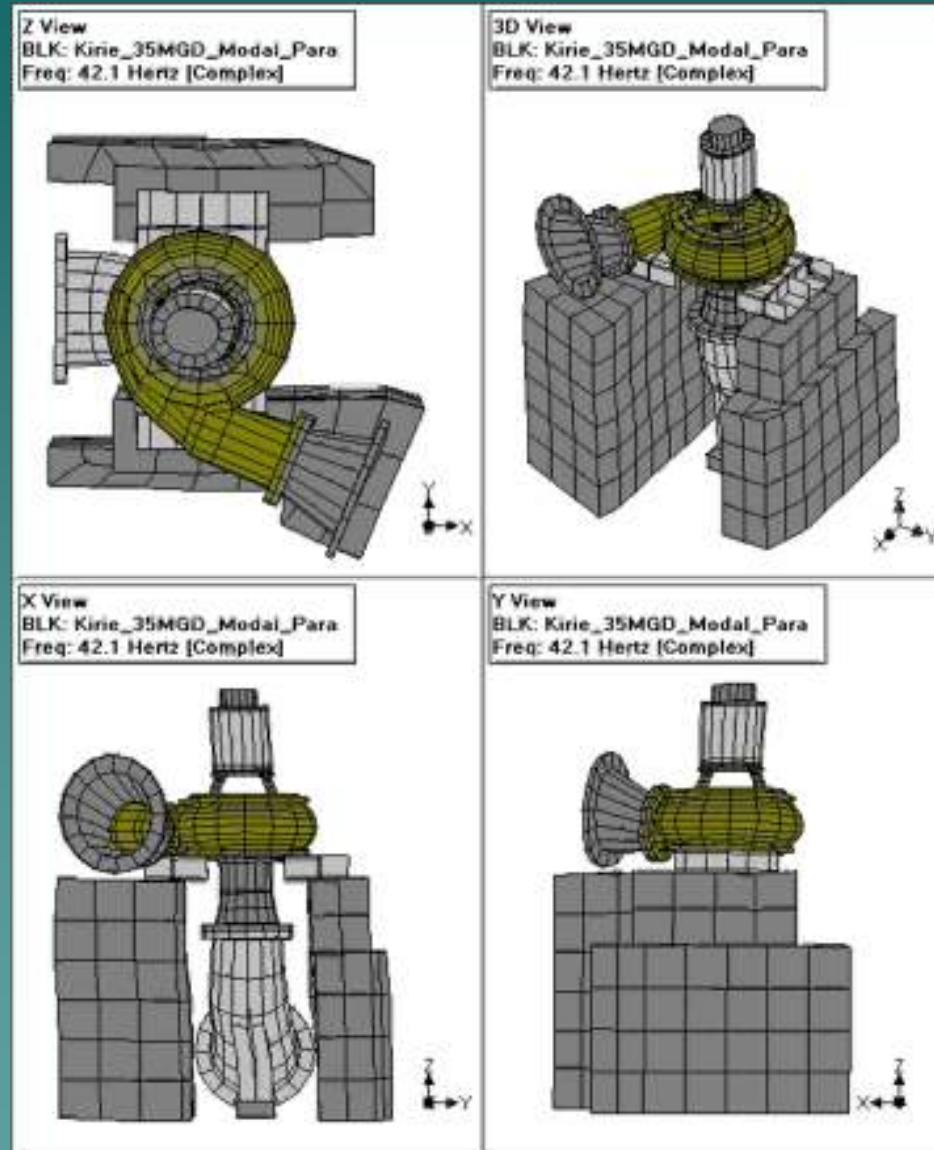

Figure 7

ODS Animation at VPF (38.0 Hz)

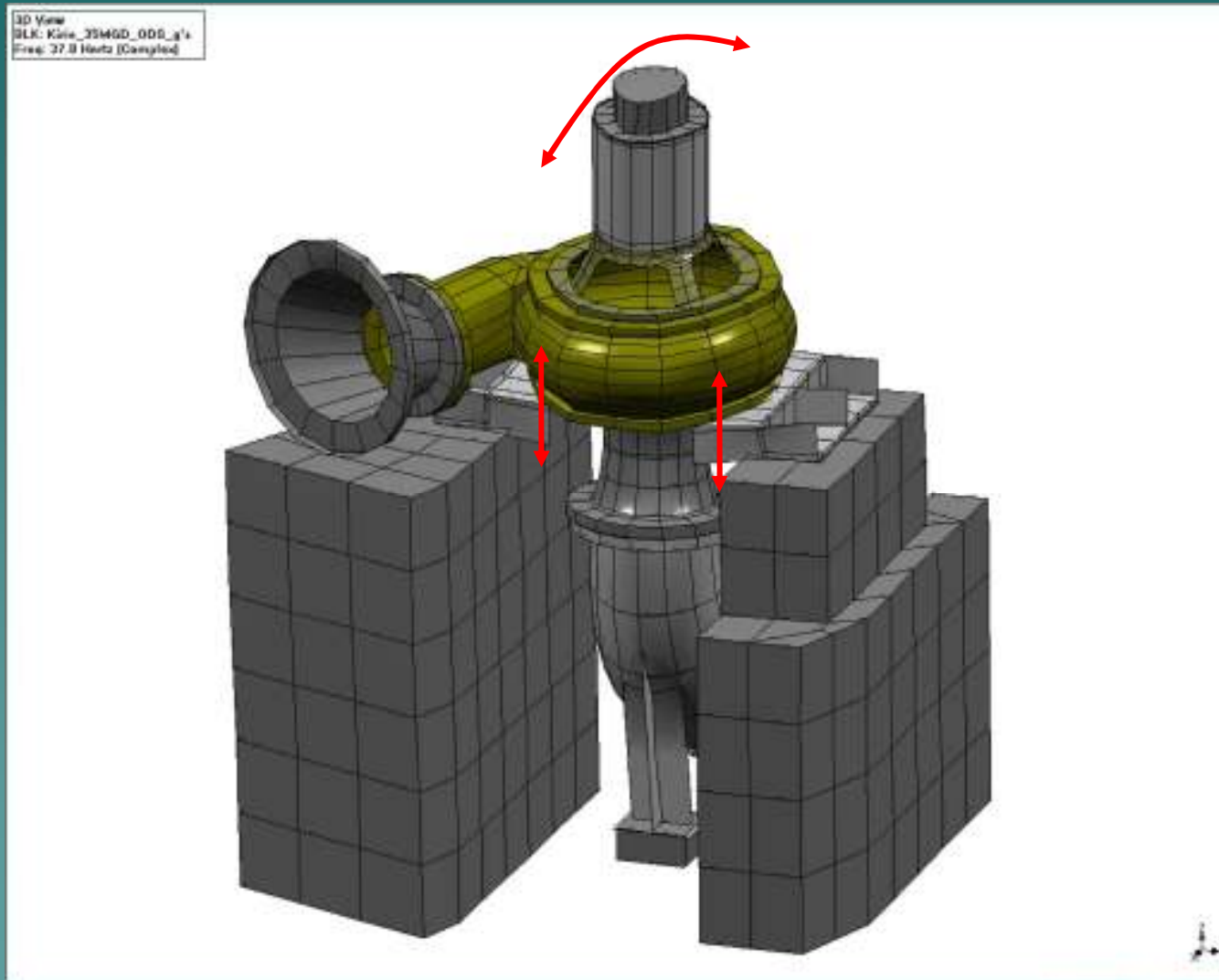
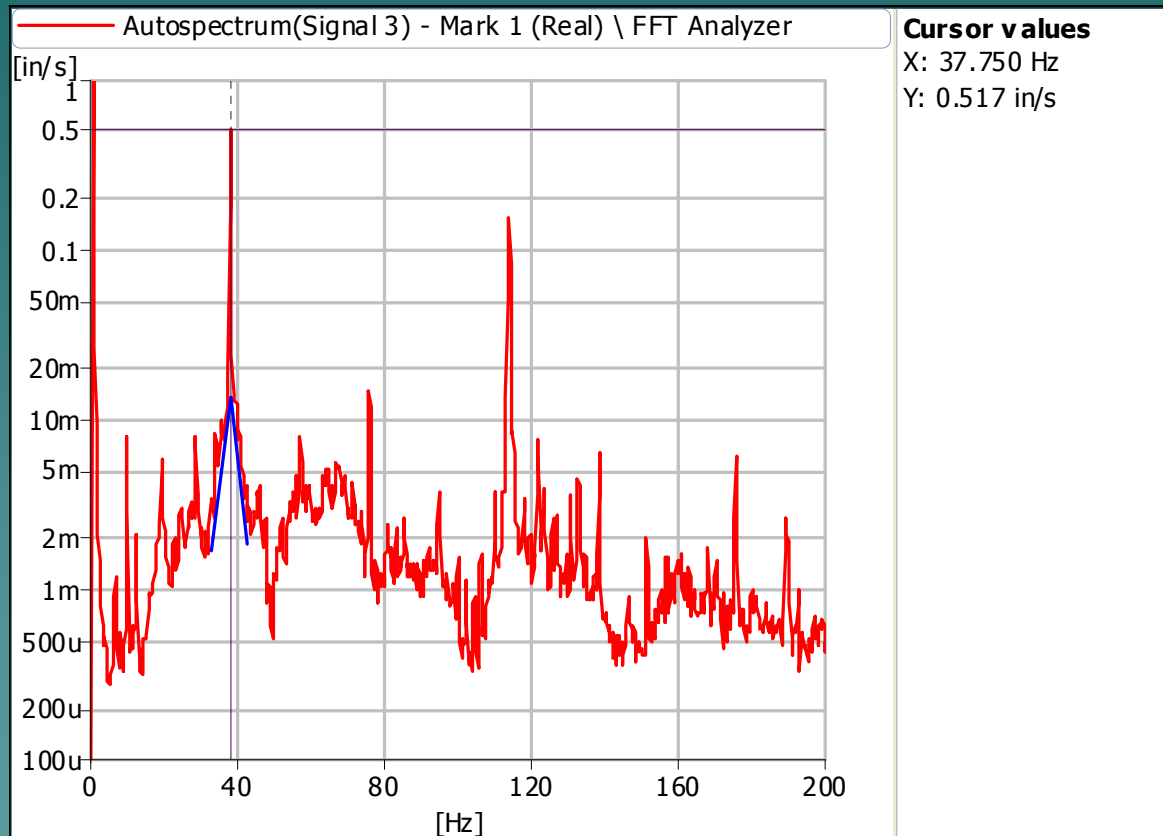

Figure 8

Forced Response FFT at Bearing Tower



Spectrum measured at the top of the bearing tower in the parallel (top) direction to the discharge pipe while the pump was running at 570 rpm

Figure 9

Preliminary Conclusions

- ◆ Clearly the high vibration was due to the casing rocking natural frequency in the vane pass operating range at 38 Hz.
- ◆ Apparently due to access issues the two piers were never connected together, but this information was never communicated back for evaluation.
- ◆ Although the model had originally predicted modes interfering with vane pass, the discharge nozzle being supported should have raised the natural frequency to just outside of the operating range albeit not with sufficient separation margin.

Preliminary Conclusions

- ◆ It was suspected that in addition to the obvious differences between what was analyzed and reality, there may have been soft foot conditions present.
- ◆ Thus, the previous finite element analysis needed to be updated to reflect the current pier configuration and casing orientation to establish a new baseline from which modifications could be evaluated.

Solid Model of Existing Pump

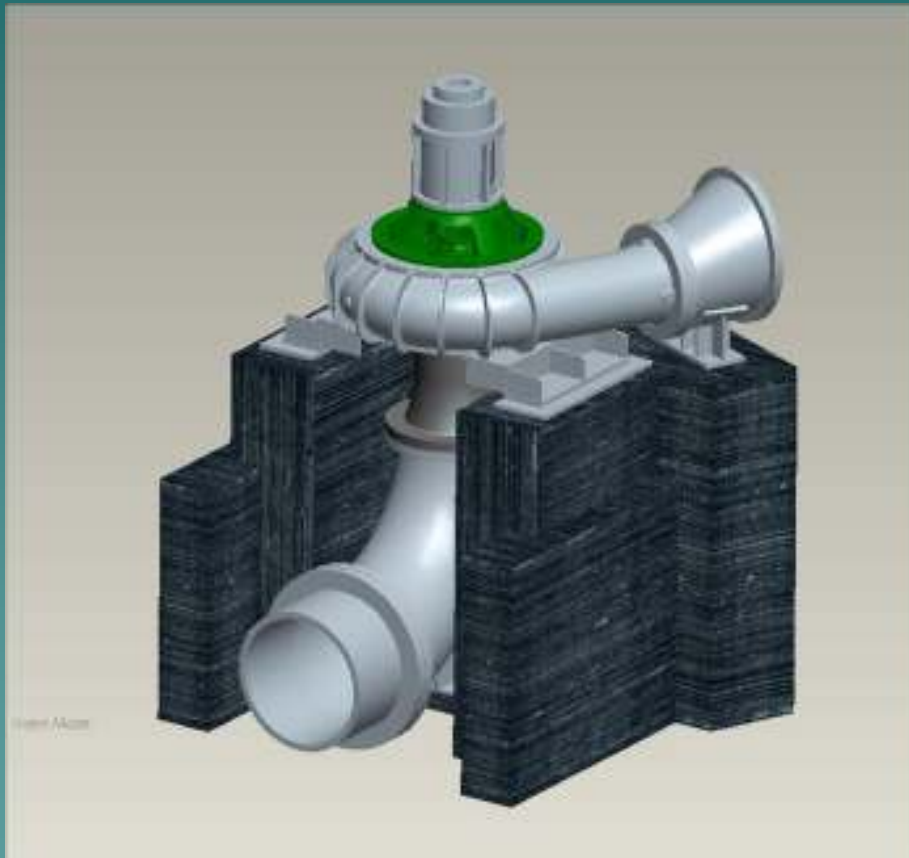

View from the suction end

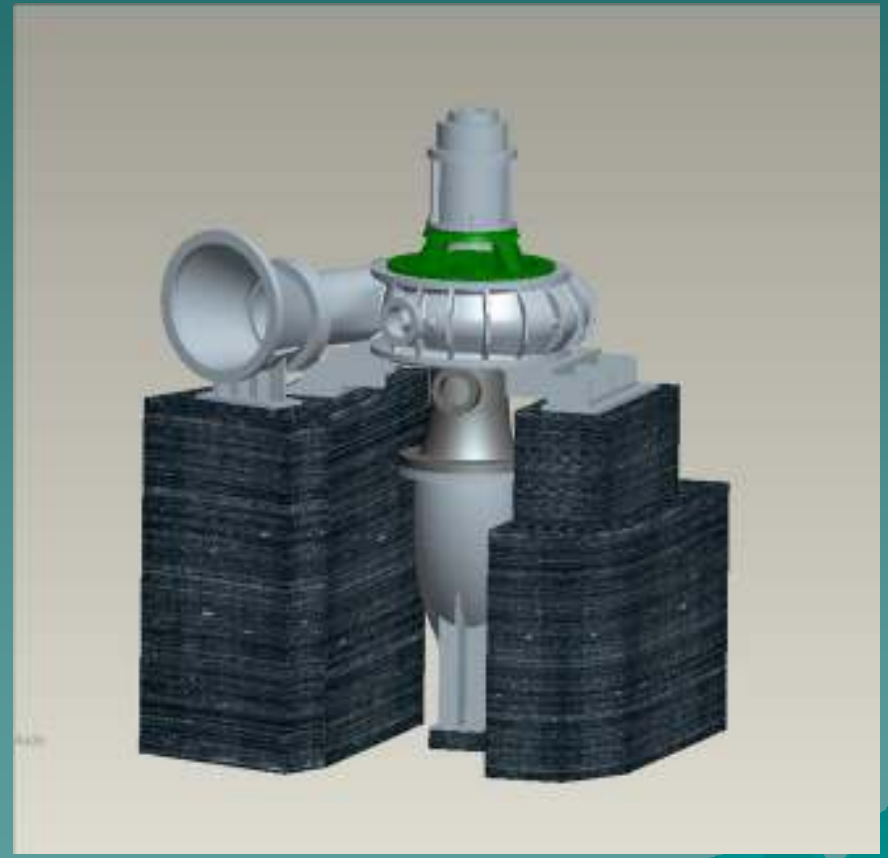

View from the discharge end

Figure 10

Analysis Results

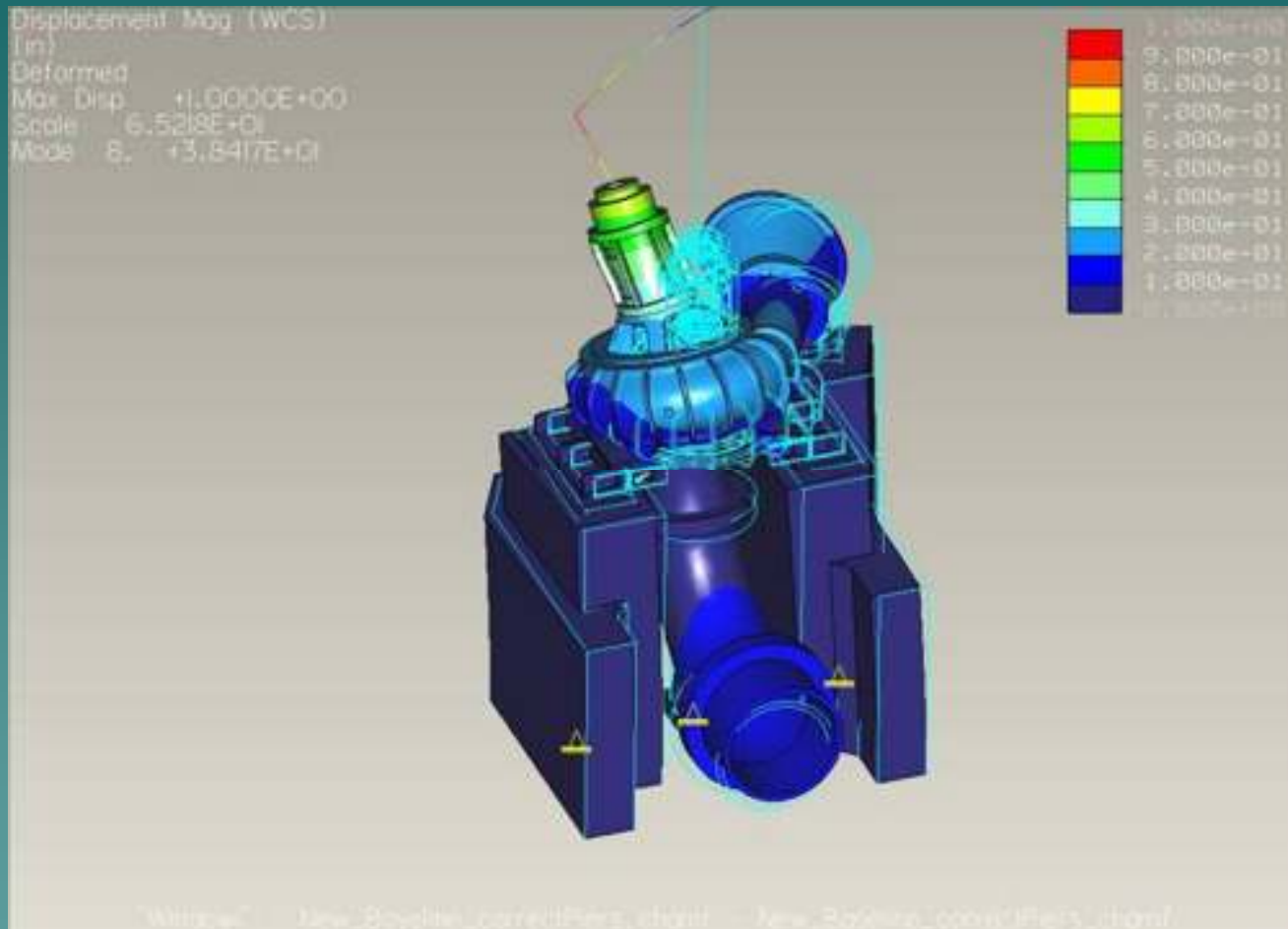

Baseline results with soft mounting at the pump support brackets – 38.4 Hz

Figure 11

Analysis Results

FEA RESULTS - Actual Existing foundation and Modifications				
Case	Description	Frequency		Separation margin (%)
		Mode 1	Mode 2	
1	Baseline - no suction pier near gate valve. Soft mount at brackets/ foundation 129" wide	38.4 Hz	42.4 Hz	-3.2%
2	Baseline - no suction pier near gate valve. With integral mount at brackets/ foundation 129" wide	41.5 Hz	43.1 Hz	4.6%
3	Concrete elevated beams front & rear/ suction pier Front concrete beam 31" thick / rear 24" thick and 34" tall 20" thk suction saddle 32.5" tall 52" wide One disch. bracket (boxed) / one suction bracket (boxed) Original side brackets (soft mount)	47.8 Hz	53.1 Hz	20.5%
4	Same as 3 with 24" thicker (vertical direction) discharge pier and 10" vertical beams on either side leaving a 32" wide by 52" tall access portal (soft mount)	49.1 Hz	54.9 Hz	23.8%
5	Same as 4 with discharge side concrete bridge only. One disch. bracket (boxed) only (soft mount) Original side brackets (soft mount)	45.1 Hz	52.5 Hz	13.7%
6	Same as 5 with discharge side concrete bridge only. One disch. bracket (boxed) only (integral mount) Original side brackets (integral mount)	50.6 Hz	55.7 Hz	27.6%
7	Same as 4 with suction side bridge beam chamfered 19" x 7". One disch. bracket (boxed) / one suction bracket (boxed) Original side brackets (soft mount)	49.0 Hz	54.9 Hz	23.5%

Table 1

Modification to Pump Support

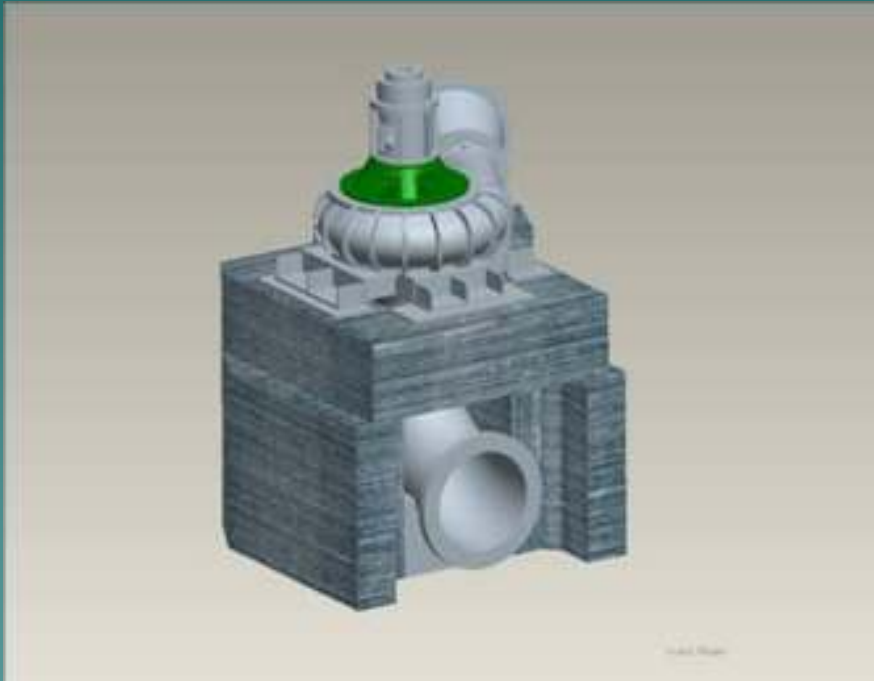

View from the suction end

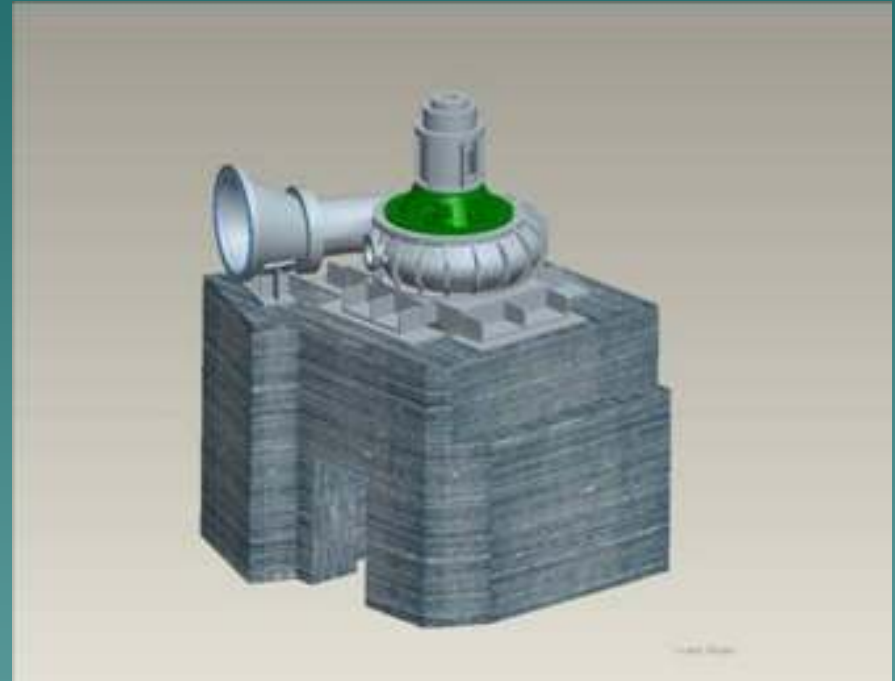

View from the discharge end

Figure 12

Modification to Pump Support

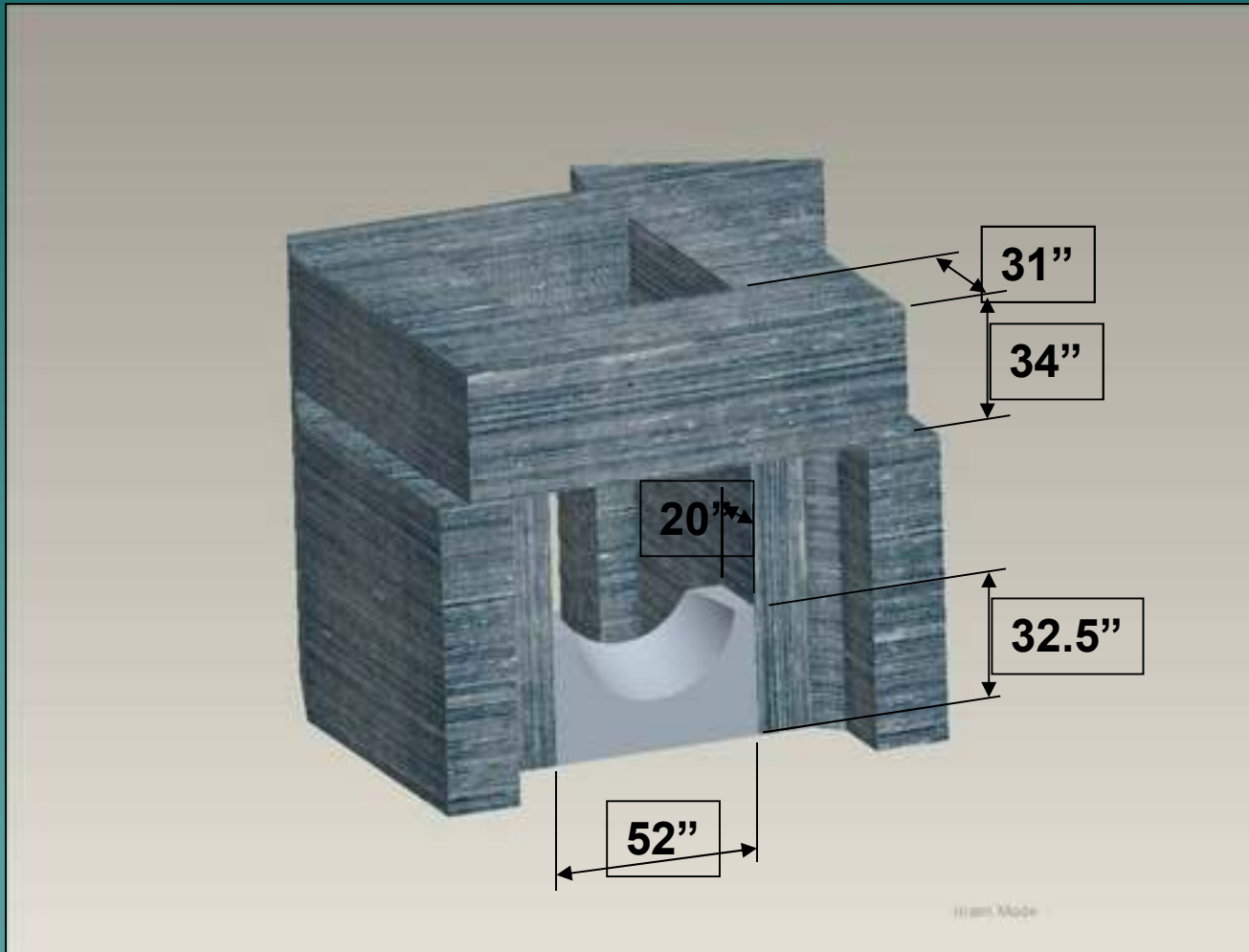
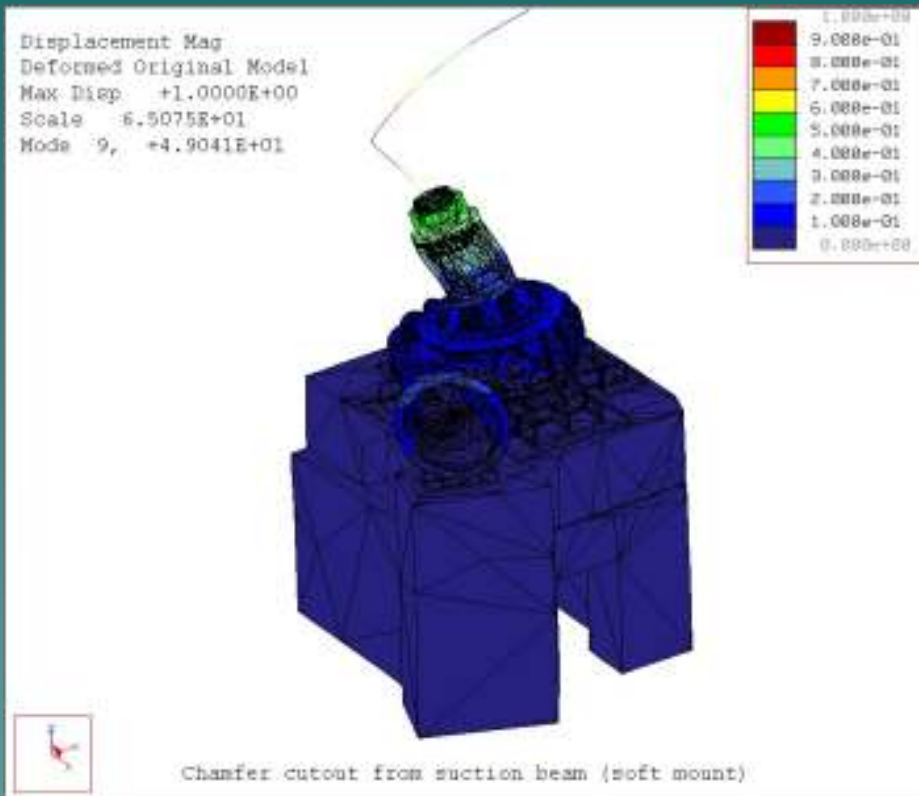
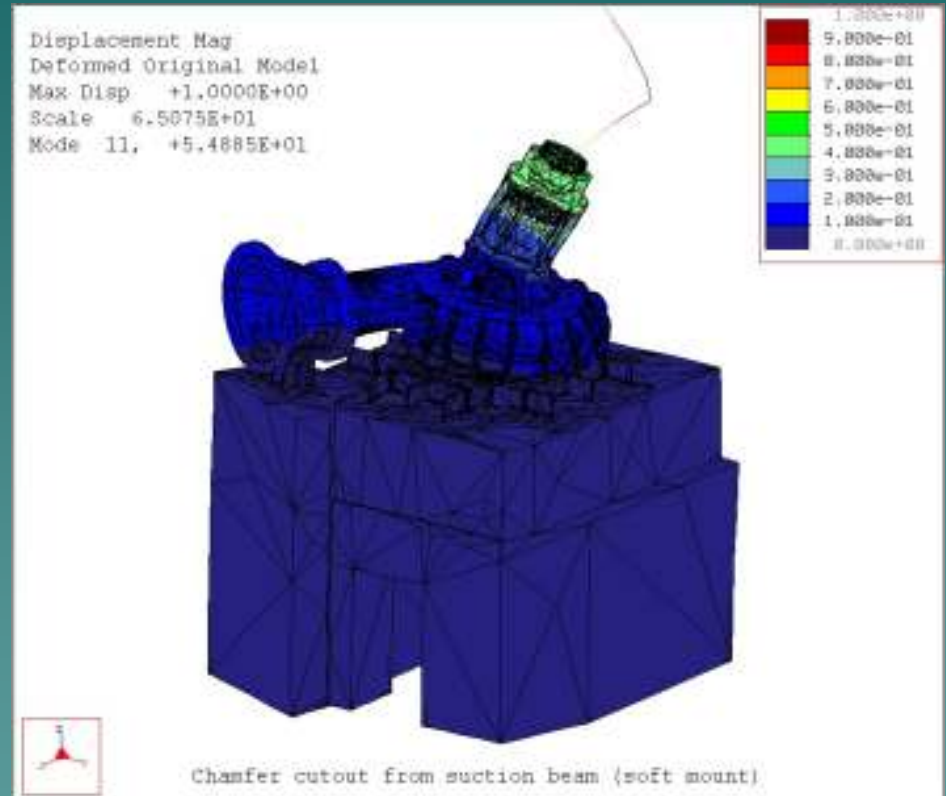

Figure 13

Final Analysis Results



Mode 1 – 49.0 Hz



Mode 2 – 54.9 Hz

Figure 14

Conclusions

- ◆ It is clear from the analysis and the subsequent field test data that concrete piers, while seemingly appearing to be rigid are indeed quite flexible especially at heights of 10 feet.
- ◆ Had the pump been just 2 feet lower, the structure would have been stiffer, and the natural frequency would not have been in the vane pass operating speed range.
- ◆ In this particular case, had the structure been analyzed as constructed, with the pump rotated 5 degrees, on two piers with the discharge pier embedded as shown, and no suction support, the analysis would have predicted only 4.6% separation margin which would have fallen well short of the specification requirement of 20%.

Conclusions

- ◆ The assumption of all plates being integral did introduce some error but this is why specifications tend to specify wider separation margins for analysis than what is necessary in the field for safe operation.
- ◆ Examination of the bracket mounting to the sole plates indicated large spans between bolts making the usual assumption of plates behaving as integral less accurate and additional bolting would have made this assumption more realistic.

Recommendations

- ◆ It is obvious that communications between the analyst, pump OEM, and contractor need to be more transparent in order to avoid such problems.
- ◆ The concrete piers were tied together and the suction nozzle supported as analyzed and two additional brackets were employed.
- ◆ The bolting torques were increased and washers added to the pump mounting bolts to spread out contact surfaces to minimize soft foot conditions.
- ◆ The discharge nozzle support bracket was inspected and found to be loose and it was re-grouted and bolts torqued to higher levels

Final Results

- ◆ After the recommended fixes were implemented, the vibration levels decreased from 0.6 in/s RMS to less than 0.2 in/s RMS at the bearing tower.
- ◆ Follow up field test by others showed that the frequencies that were at 38 Hz had shifted to 46Hz and 52.5Hz, close to analysis predictions.

Final Results

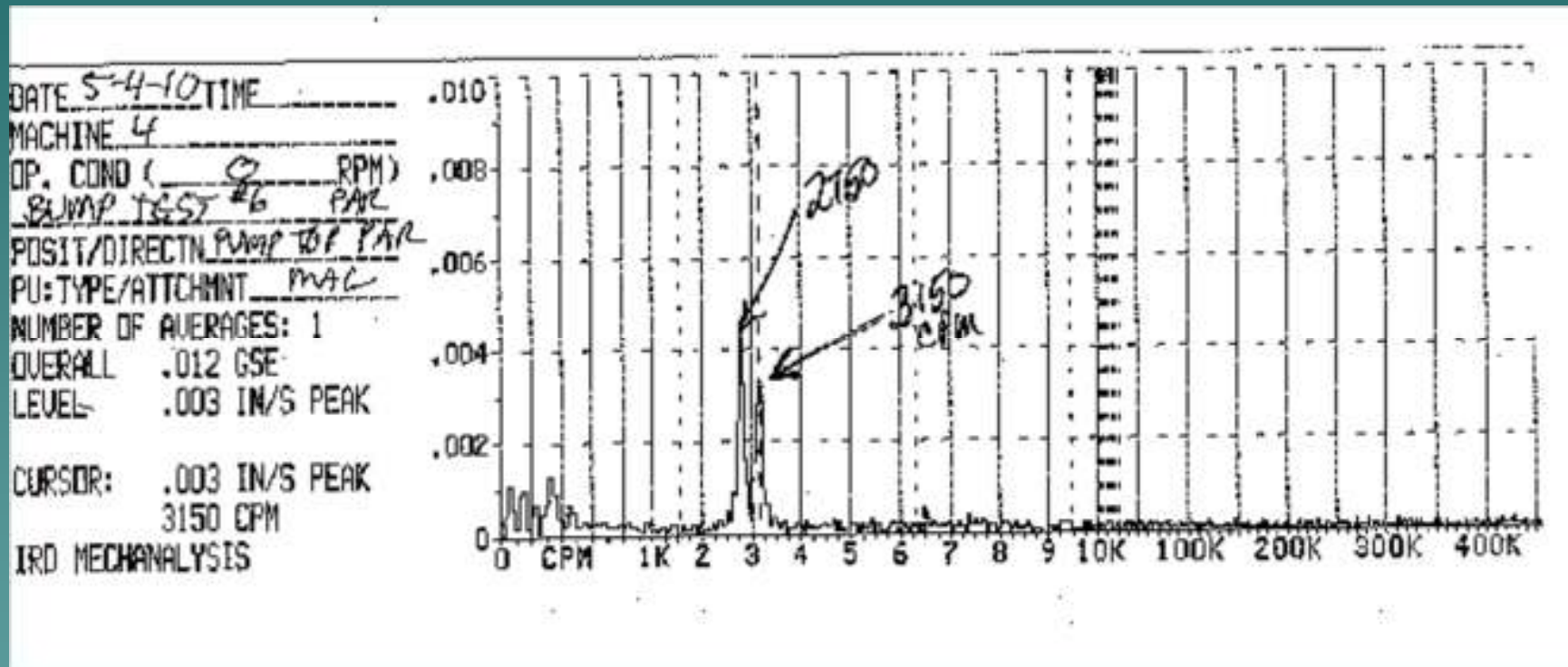

Figure 15