

**ABSTRACT FOR USER CASE STUDY**  
**17<sup>th</sup> International Pump Users Symposium**

**Title:**

**“SUCCESSFUL MODIFICATION OF VERTICAL-TURBINE PUMPS FOR CAPACITY AND RELIABILITY IMPROVEMENT”**

**Abstract:**

A modification of seven 560 hp vertical-turbine pumps was carried out with outstanding results to improve their actual capacity. The installation was limited to 64% of its rated capacity, which was never reached, and the operating demand required to maintain all seven pumps in continuous service. Reliability of the pumps was additionally impaired by severe cavitation damage of impellers.

A plant revamp required increased and reliable cooling water flow, with a limited time frame of seven months for full implementation. Original cast iron impellers were reverse engineered and manufactured oversize in 18Cr-16Mn steel. Bowls were modified for the larger impellers. Performance for all pumps was adjusted in a test stand and the efficiency improved not to exceed the rated horsepower of installed electric motors.

As a result, the capacity of the installation reached its rated value. Operation was optimized with six pumps in operation and one in standby feeding 33% more water. After 26 months in service, none of the pumps had shown capacity drop or required maintenance beyond repacking. Significant savings were attained compared to the installation of new pumps.

**AUTHOR:**

**César A. Morales Casanova**  
*Rotating Equipment Specialist*  
*PDVSA – Pequiven*  
*UNF Morón, Edo. Carabobo*  
*Venezuela*

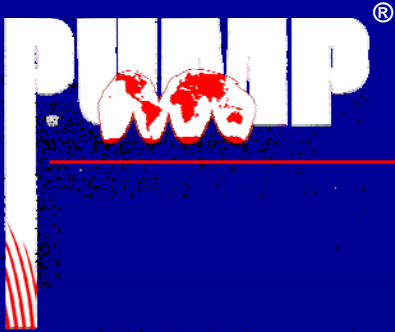

*17<sup>th</sup> International Pump Users Symposium*

*March 6-9, 2000. Houston, Texas*

---

***SUCCESSFUL MODIFICATION  
OF VERTICAL-TURBINE PUMPS  
FOR CAPACITY  
AND RELIABILITY IMPROVEMENT***

***César A. Morales Casanova***

**Rotating Equipment Specialist**

**PDVSA-Pequiven**

**Edo. Carabobo - Venezuela**

# ***SITUATION OVERVIEW***

- ▶ 28 year old Cooling Tower servicing a 600 MTD Ammonia Plant and a 750 MTD Urea Plant.
- ▶ Seven 560 HP cooling water pumps installed (Four turbine driven and three motor driven). European OEM.
- ▶ An additional pump kept as a spare.



## ***SITUATION OVERVIEW (cont...)***

---

- ▶ **Pump efficiency was reduced due to severe cavitation damage of impellers, causing additional limitations to cooling water feed.**



***IMPELLER CONDITION AFTER 1 YR IN SERVICE***

# ***PROJECT SCOPE / OBJECTIVES-PREMISES***

---

- ▶ **Ammonia plant revamp to 680 MTD to be implemented.**
- ▶ **Reliable and increased cooling water flow up to 16,000 m<sup>3</sup>/hr (70,400 GPM) required.**
- ▶ **Seven months available for full implementation:**
  - **Workscope analysis started by mid August 1996.**
  - **Equipment required in service by May 1997.**



# ***CAPACITY EVALUATION OF EXISTING PUMPS***

---

- ▶ One pump completely overhauled for testing.
- ▶ A new impeller –as supplied by the OEM– installed.



# TEST-STAND RESULTS – UNMODIFIED PUMP

PUBLISHED VS. TEST PERFORMANCE  
OEM IMPELLER  $\phi 550/500$  mm @1170 RPM

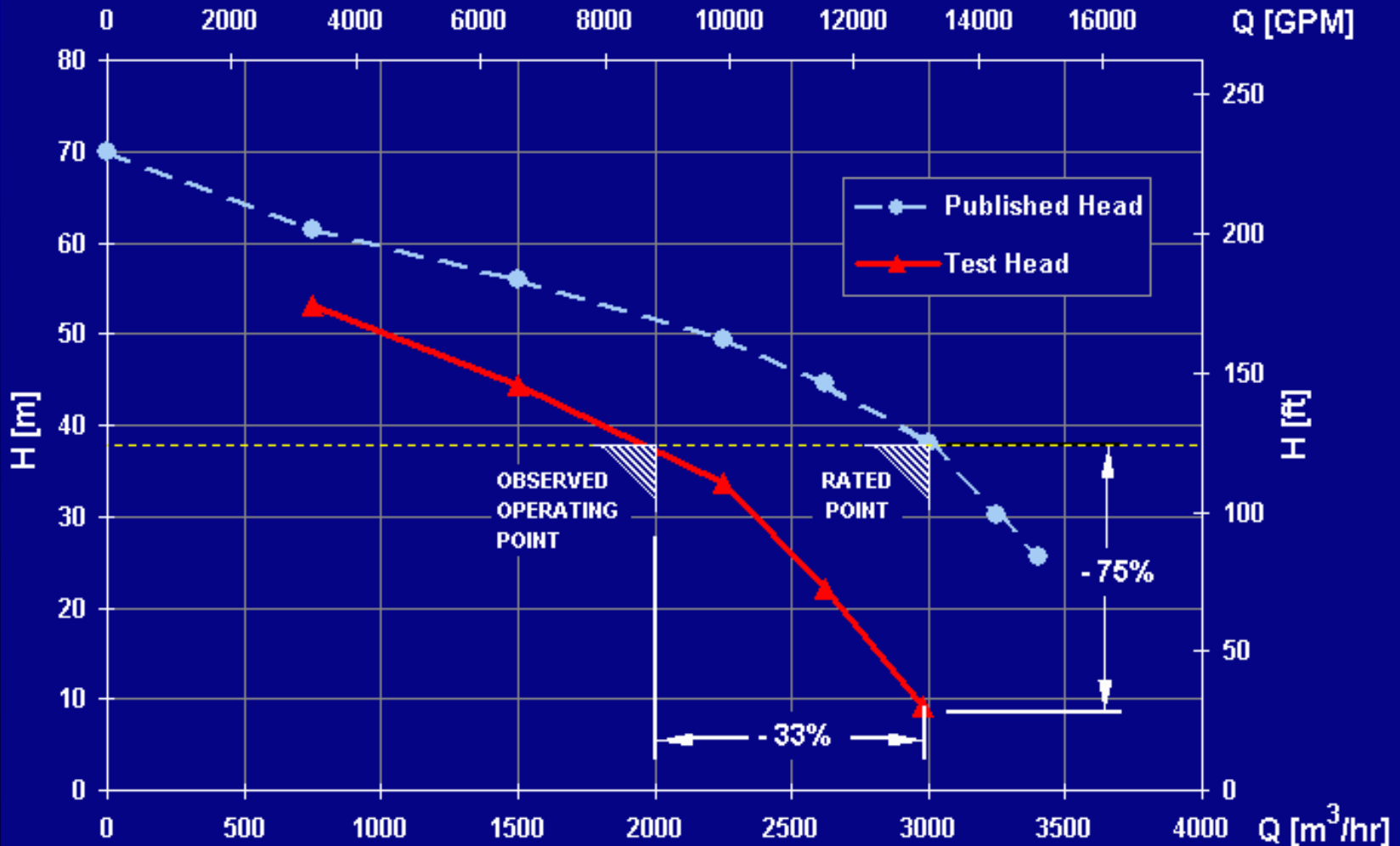

# TEST RESULTS OF EXISTING PUMP

PUBLISHED VS. TEST PERFORMANCE  
OEM IMPELLER  $\phi 550/500$  mm @1170 RPM

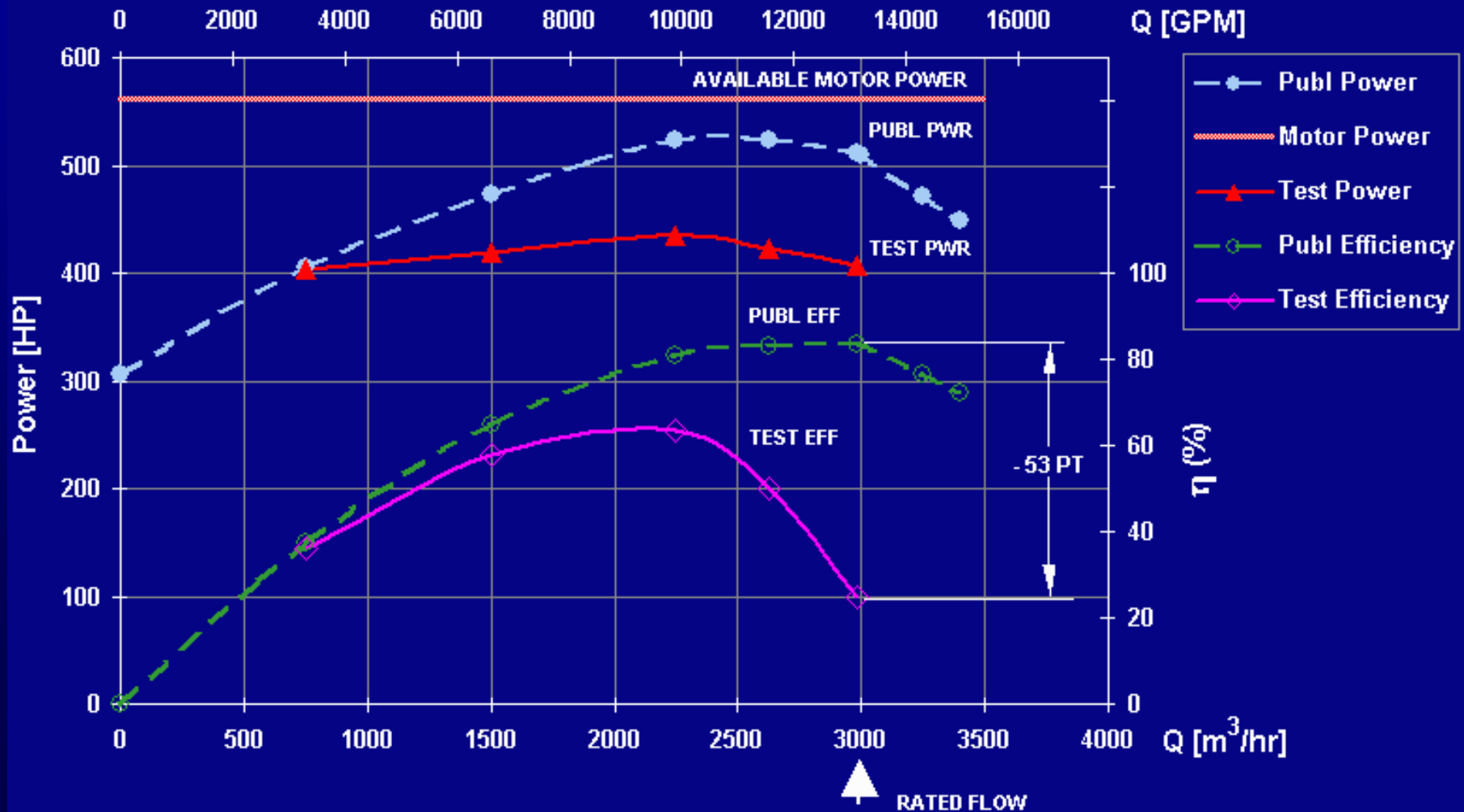



# **TEST-STAND RESULTS – UNMODIFIED PUMP**

---

- ▶ **Actual capacity @ rated head found 33% below:**

**Found: 2,000 m<sup>3</sup>/hr (8,800 GPM)**

**Rated: 3,000 m<sup>3</sup>/hr (13,200 GPM)**

- ▶ **Pump could not reach rated flow:**

**Max attainable: 2,970 m<sup>3</sup>/hr (13,068 GPM)**

- ▶ **TDH nearest rated flow was 75% below:**

**Found: 9.5 m (30 ft)**

**Rated: 38.0 m (125 ft)**

- ▶ **BEP was found at 79% of the expected flow and well below in efficiency:**

**Found: 64% @ 2,200 m<sup>3</sup>/hr (9,680 GPM)**

**Expected: 83% @ 2,800 m<sup>3</sup>/hr (12,320 GPM)**

# **TEST-STAND RESULTS – UNMODIFIED PUMP CONCLUSIONS / RECOMMENDATIONS**

---

- ▶ **Considerable performance impairment compared to expected.**
- ▶ **Impeller subject to severe cavitation before reaching rated flow.**
- ▶ **Significant improvement not possible by reworking of existing impellers (underfilling).**
- ▶ **Major modifications required to accomplish project objectives.**
- ▶ **A prototype pump to be modified and re-tested.**

# PLANNED MODIFICATIONS - IMPELLER

- ▶ Largest oversize impeller that could be fitted in existing bowls locally manufactured.
- ▶ Material improved from Cast Iron to cavitation resistant Stainless Steel 18Cr-16Mn Alloy.

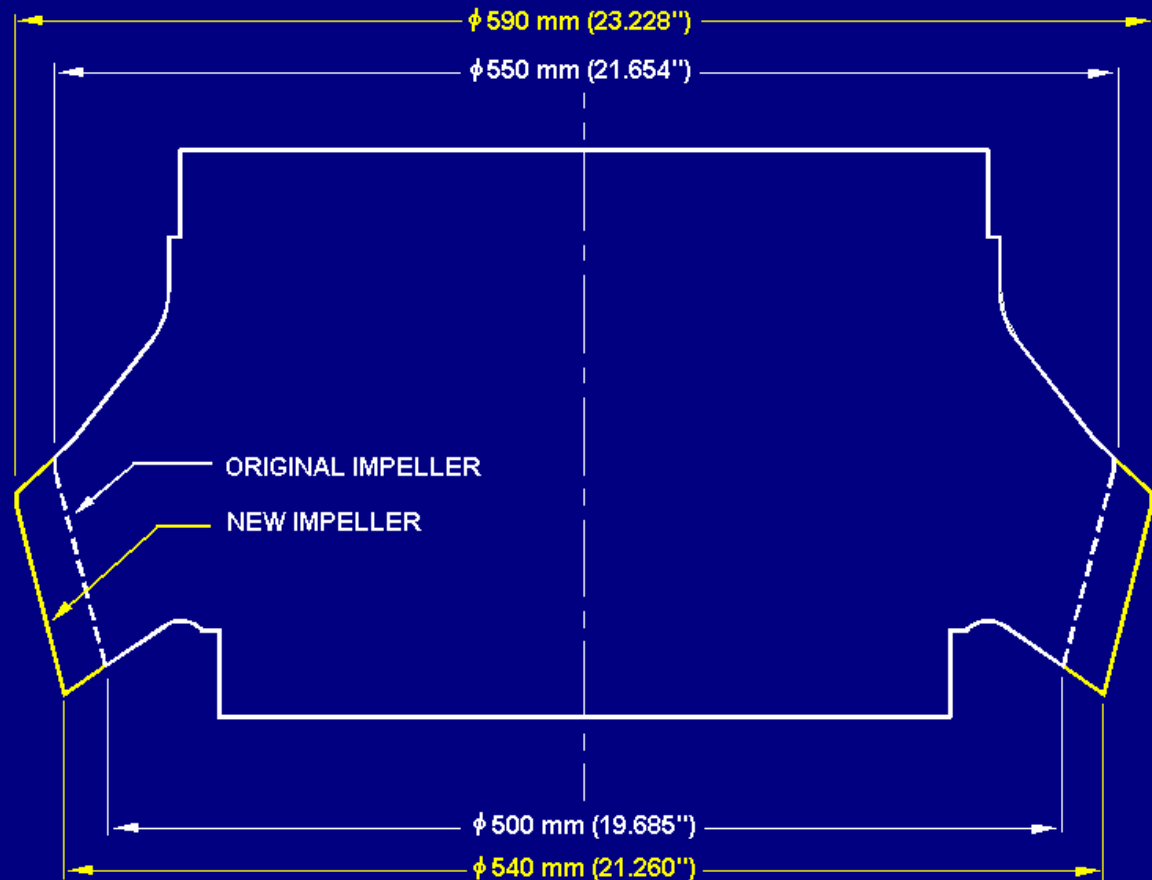

# PLANNED MODIFICATIONS – BOWL

- ▶ Suction Bell fit diameter increased.
- ▶ GAP "A" set to 2.5 mm (0.10 in).
- ▶ Diffuser vanes cut back. Leading edges thinned & rounded.
- ▶ Even number of vanes for both impeller and diffuser:
  - 6 vane impeller.
  - 8 vane diffuser.
- ▶ Gap "B" set to 10% of new impeller vane radius = 30 mm (1.18 in).

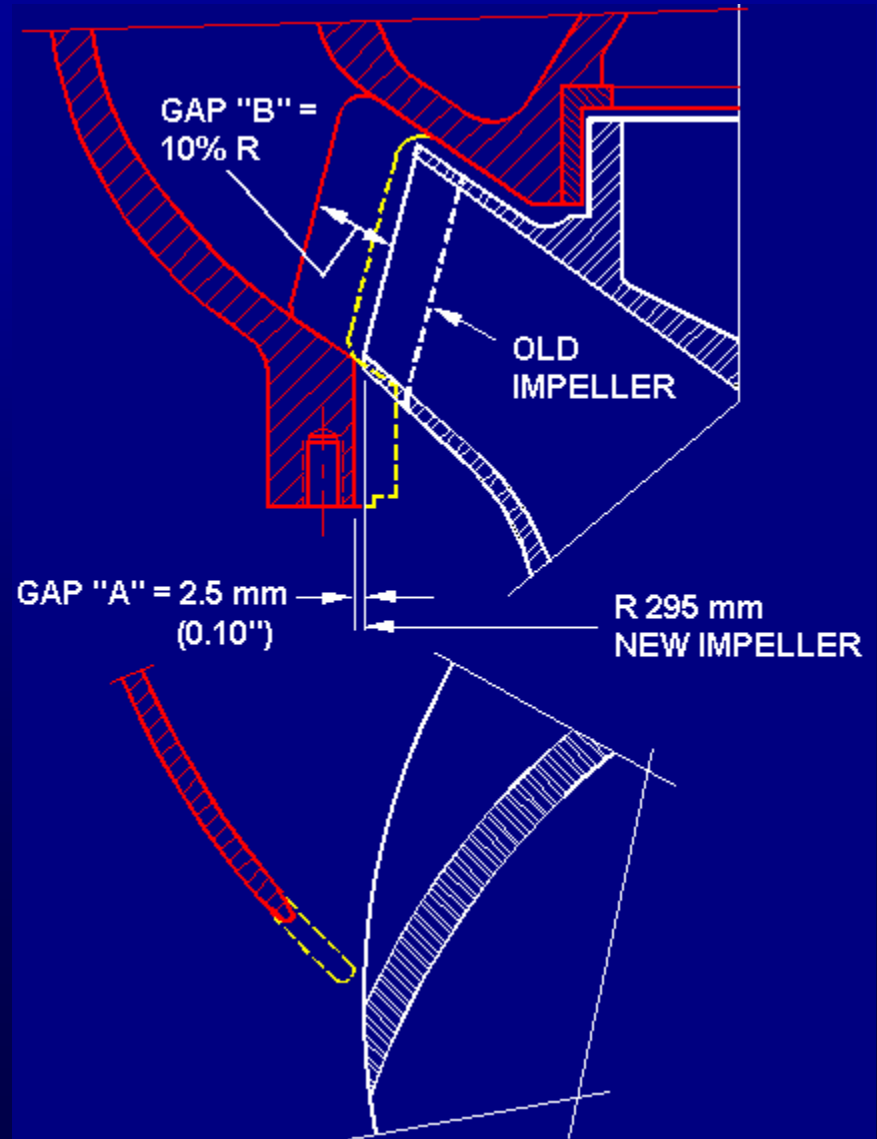

# ***MODIFIED COMPONENTS - NEW IMPELLER***

---

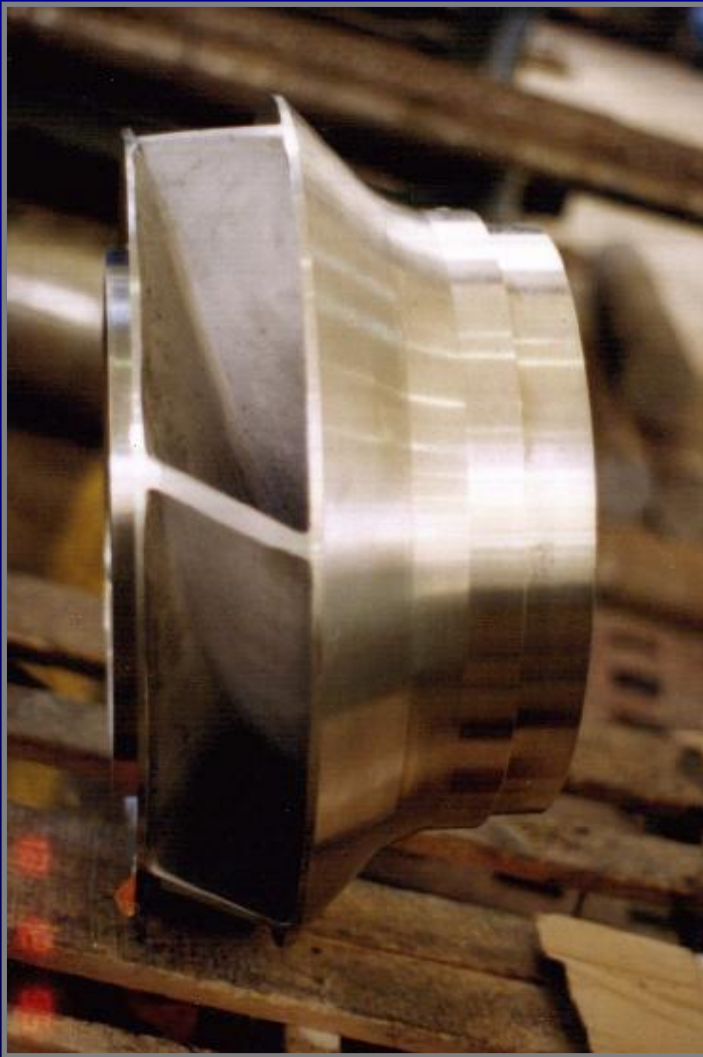

**FIRST IMPROVED IMPELLER "AS SUPPLIED"- DEC'96**

# **MODIFIED COMPONENTS – BOWL REWORK**



**IMPELLER TEMPLATE INSERTED**

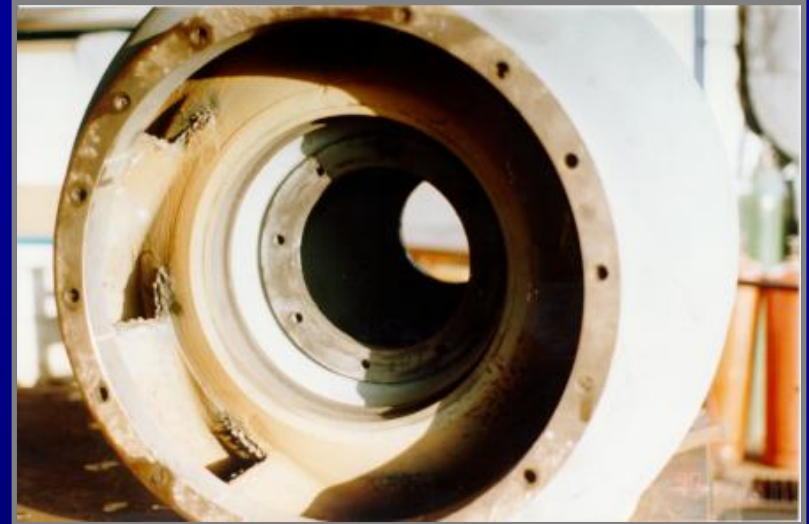

**VANE ROUGH CUT**



**VANE CUT MARKING**



**FINISHED BOWL**



# TEST-STAND RESULTS – PROTOTYPE PUMP

PUBLISHED VS. TEST PERFORMANCE  
AS RECEIVED NEW IMPELLER  $\phi 590/540$  mm @1188 RPM

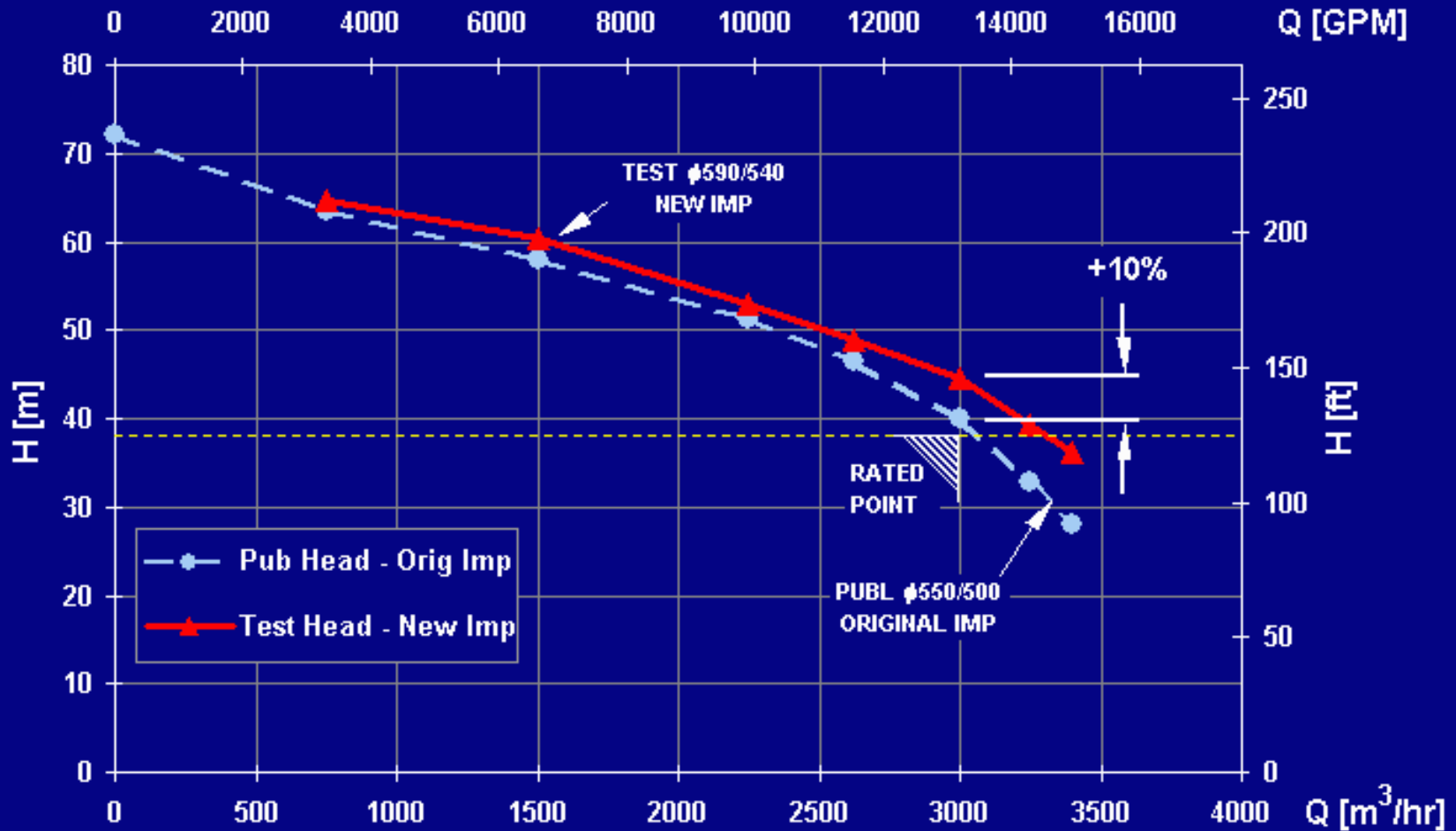

# TEST-STAND RESULTS – PROTOTYPE PUMP

PUBLISHED VS. TEST PERFORMANCE  
AS RECEIVED NEW IMPELLER  $\phi 590/540$  mm @1188 RPM

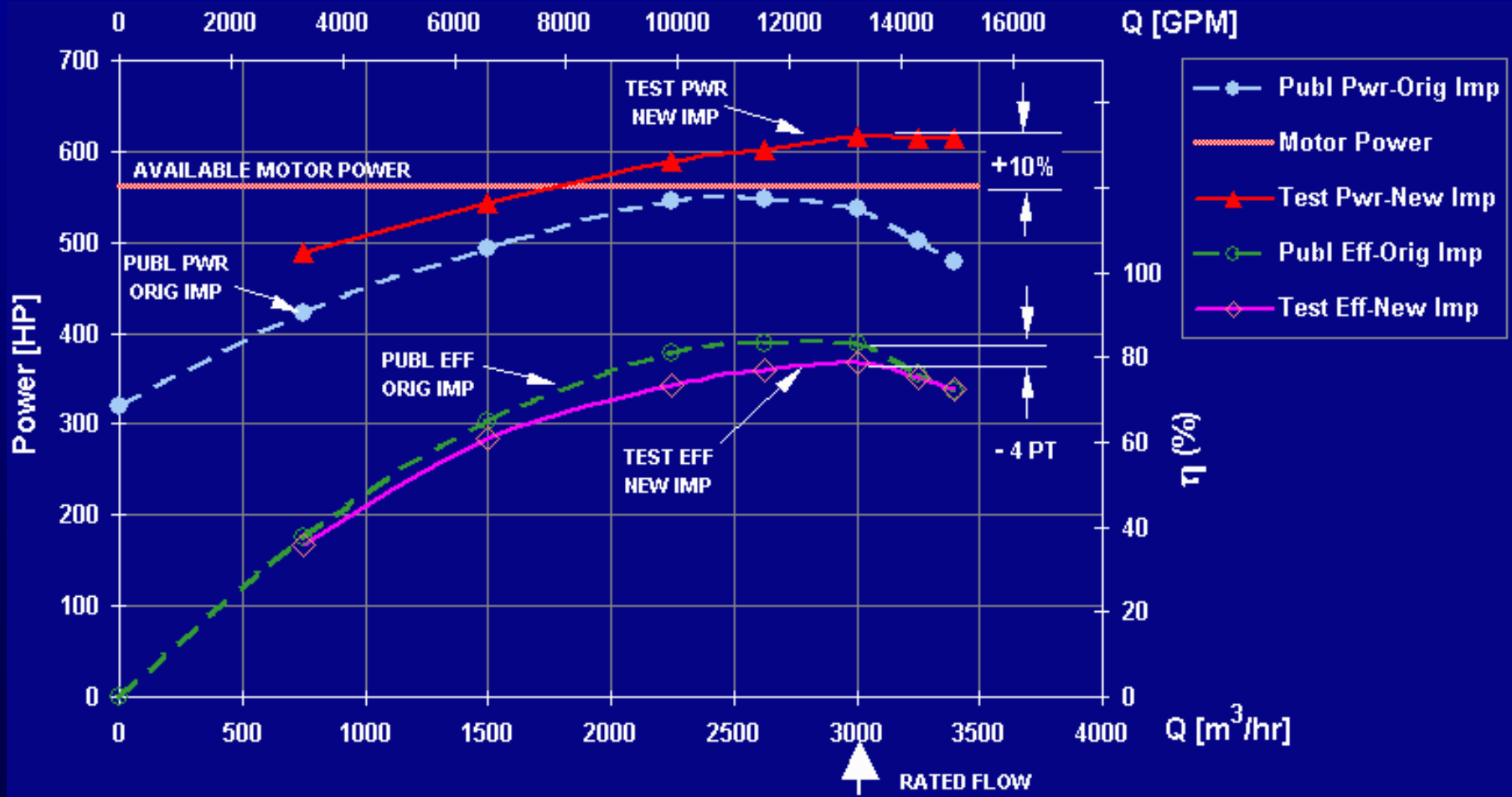

# ***TEST-STAND RESULTS – PROTOTYPE PUMP***

---

- ▶ **Actual capacity @ rated head found 8% above:**
  - Found: 3,250 m<sup>3</sup>/hr (14,300 GPM)**
  - Rated: 3,000 m<sup>3</sup>/hr (13,200 GPM)**
- ▶ **Pump exceeded rated flow:**
  - Max attainable: 3,400 m<sup>3</sup>/hr (14,960 GPM)**
- ▶ **TDH @ rated flow/rpm was 10% above:**
  - Found: 42 m (138 ft)**
  - Rated: 38 m (125 ft)**
- ▶ **BEP found @ rated flow and slightly below in efficiency:**
  - Found: 79% @ 3,000 m<sup>3</sup>/hr (13,200 GPM)**
  - OEM Published: 83% @ 2,800 m<sup>3</sup>/hr (12,320 GPM)**
- ▶ **BEP found @ rated flow and slightly below in efficiency:**
  - Max HP: 620 @ 3,000 m<sup>3</sup>/hr (13,200 GPM)**
  - Motor HP: 562 (1.0 S.F.)**

# ***TEST-STAND RESULTS – PROTOTYPE PUMP CONCLUSIONS / RECOMMENDATIONS***

---

- ▶ **Performance significantly improved.**
- ▶ **Rated point easily reached and exceeded.**
- ▶ **BEP matched rated flow.**
- ▶ **Limitation in available power from installed electrical motors.**
- ▶ **Impeller rework required to adjust performance.**
- ▶ **Efficiency improvement required to reach rated point and limit power requirement.**

# PERFORMANCE ADJUSTMENT IMPELLER REWORK

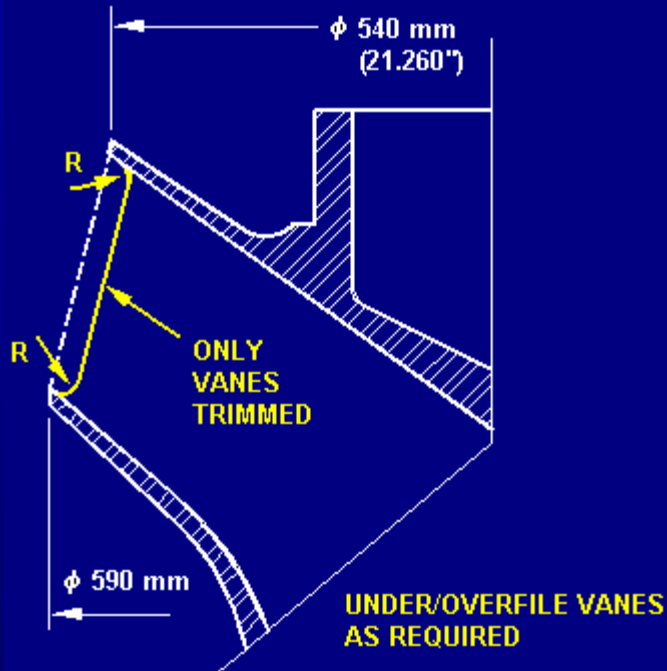

- ▶ Vanes trimmed.
- ▶ Shrouds not machined to keep GAP "A" at 2.5 mm (0.10 in).
- ▶ Vane exit under/overfilled.
- ▶ Vane leading edge rounded & thinned to improve NPSHR.
- ▶ Vane surface finish improved to increase efficiency.

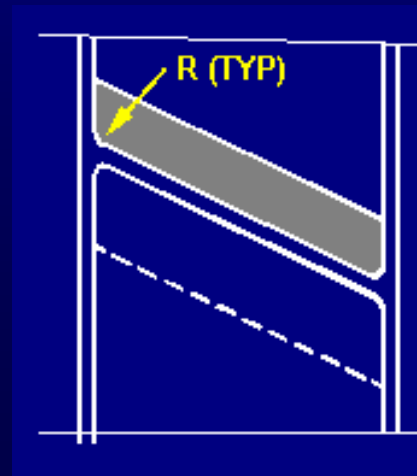
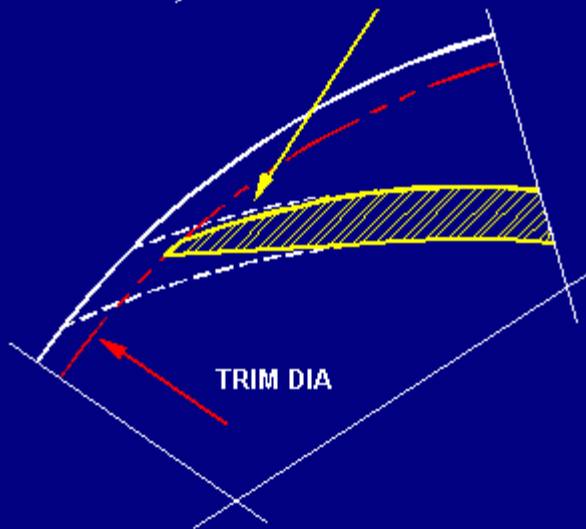

# **PERFORMANCE ADJUSTMENT IMPELLER REWORK**



**"AS SUPPLIED" VANE EXIT**



**"AS SUPPLIED" ROUGH VANE SURFACE**



**ADJUSTED (UNDER/OVERFILLED)  
VANE EXIT**

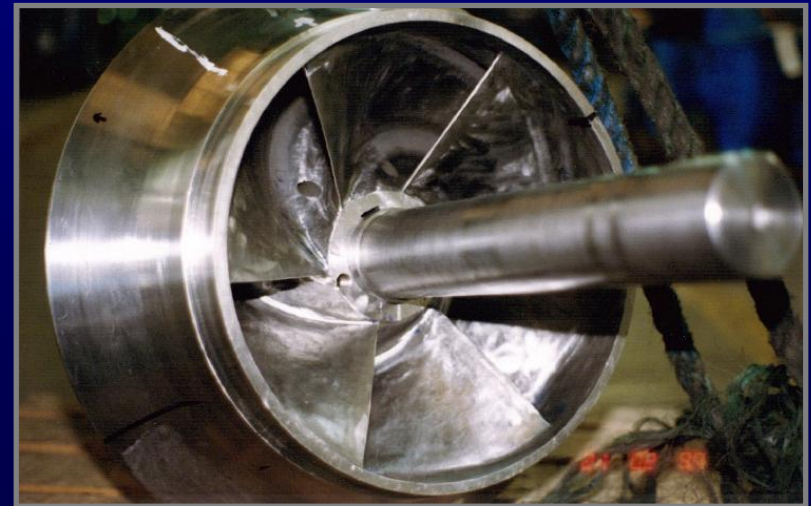

**VANES POLISHED  
LEAD EDGE ROUND & THIN**



# TEST STAND RESULTS - FINAL

## PUBLISHED VS. TEST PERFORMANCE REWORKED NEW IMPELLER $\phi 577/527$ mm @1188 RPM

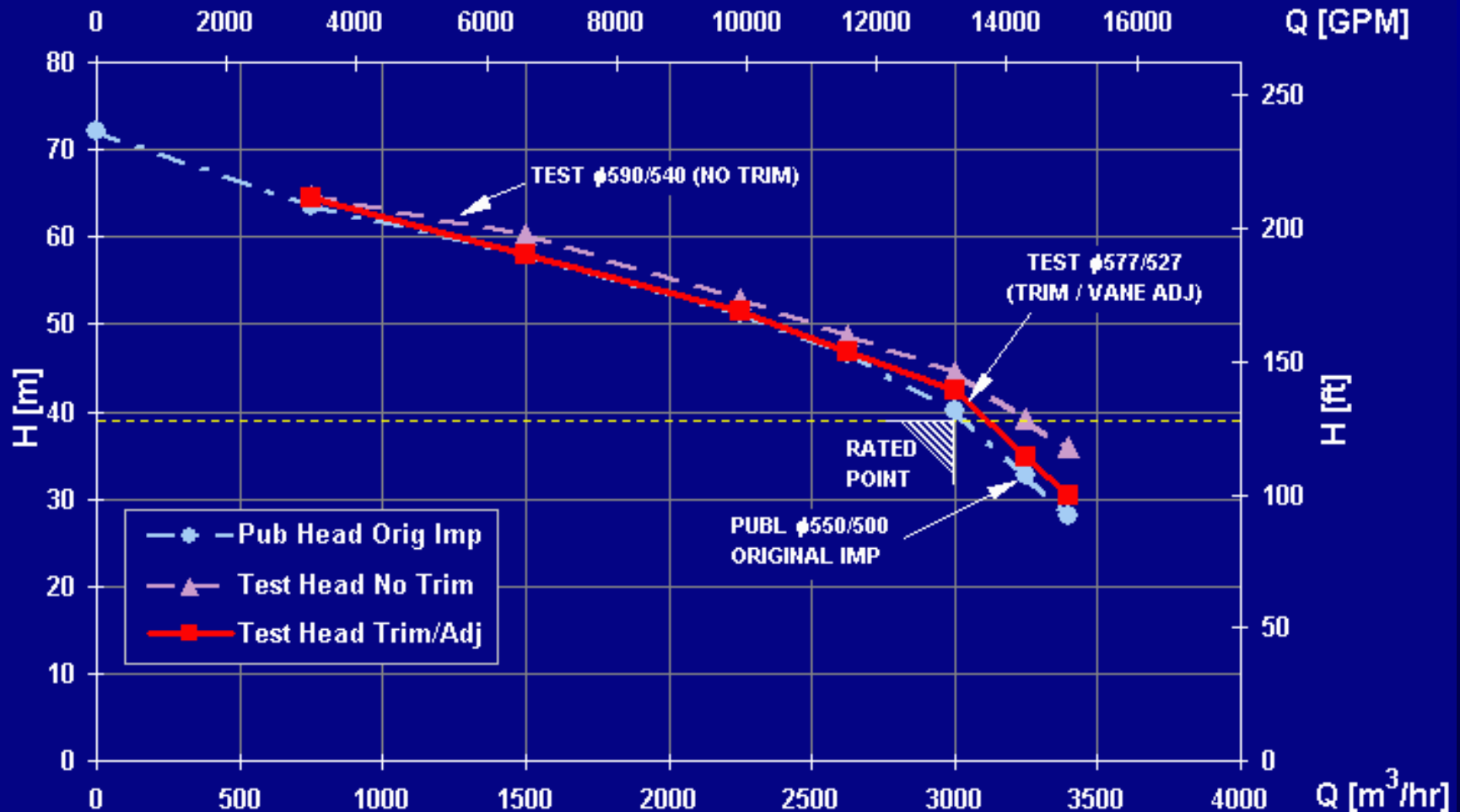

# TEST STAND RESULTS - FINAL

## PUBLISHED VS. TEST PERFORMANCE REWORKED NEW IMPELLER $\phi 577/527$ mm @1188 RPM

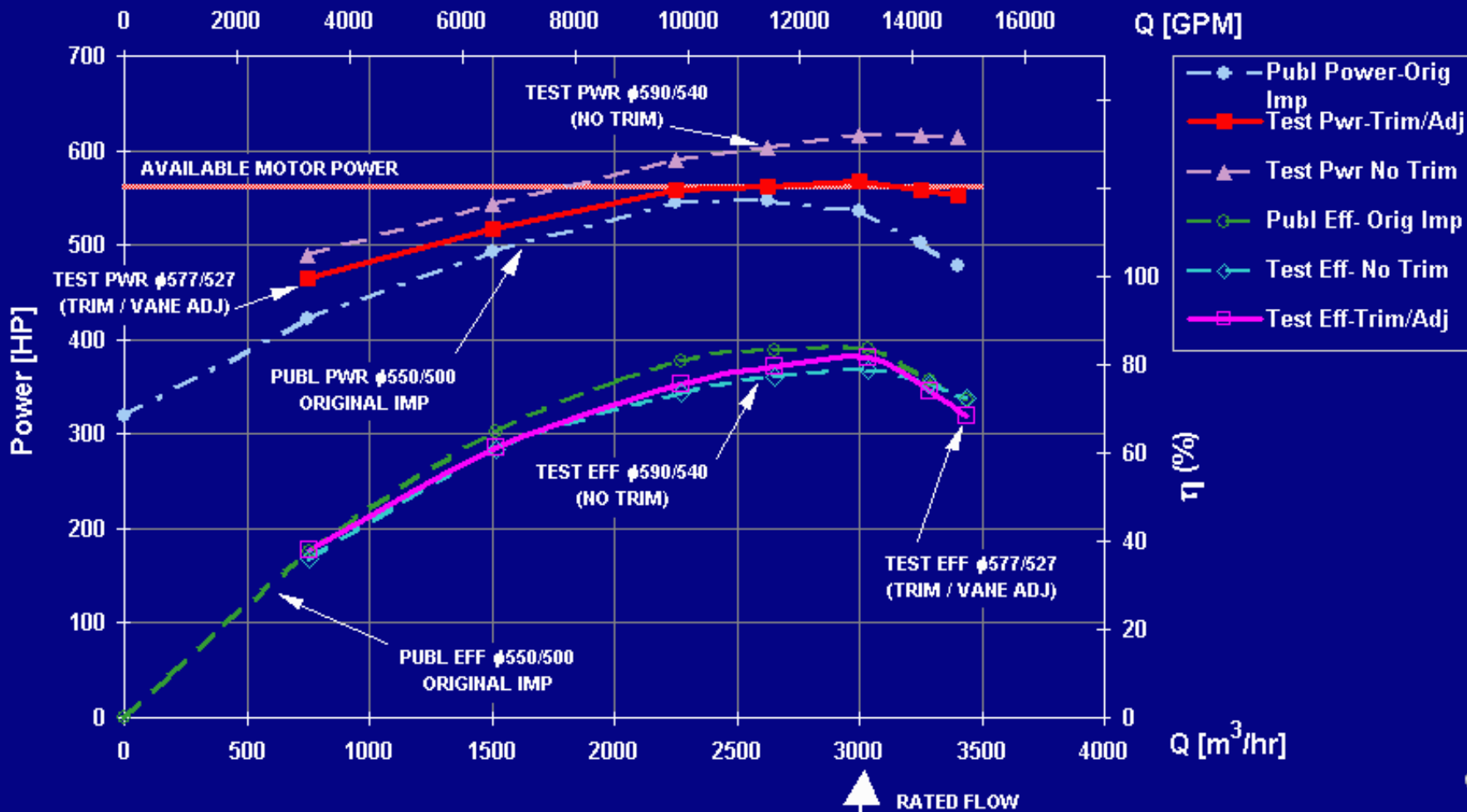

# **TEST STAND RESULTS - FINAL**

---

- ▶ **Operating point closely adjusted:**

  - TDH @ rated flow within +5% of rated value.**

- ▶ **Efficiency at BEP improved by 3 points:**

  - Final: 82%**

  - Before adjustment: 79%**

- ▶ **Shaft horsepower adjusted:**

  - Max BHP within +1.5% of motor nameplate value (\*)**

\* (Pump BHP based on electrical measurements,  $\eta_{mec}$  assumed 90%).

# ***OVERALL RESULTS***

---

- ▶ **Pump improvement completed on time, in May '97.**
- ▶ **Optimized operation:**
  - **Installed capacity fully recovered (155% increase).**
  - **6 pump running / 1 stand-by.**
  - **18,000 m<sup>3</sup>/hr (79,200 GPM) continuously delivered.**
- ▶ **Increased reliability:**
  - **Pump performance sustained after 2-1/2 years.**
  - **Extended impeller service life.**
  - **Maintenance costs significantly reduced**
- ▶ **Savings of US\$ 1.4 million compared to the alternative of replacing existing pumps.**
- ▶ **Eight pumps were modified at the cost of a single new unit (approx. US\$ 200 k)**

# ***RESULTS – IMPELLER SERVICE LIFE***

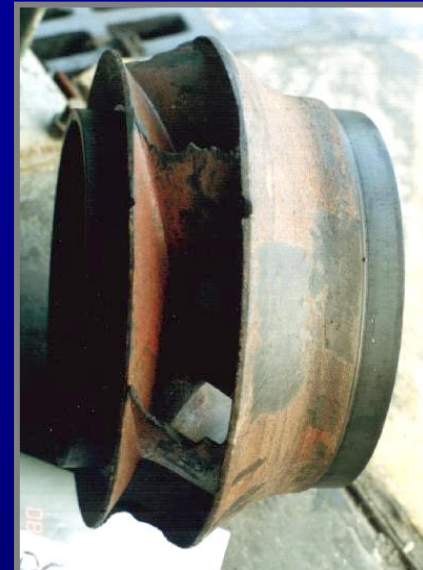

**AGOSTO 1996 – 1 YEAR IN SERVICE**

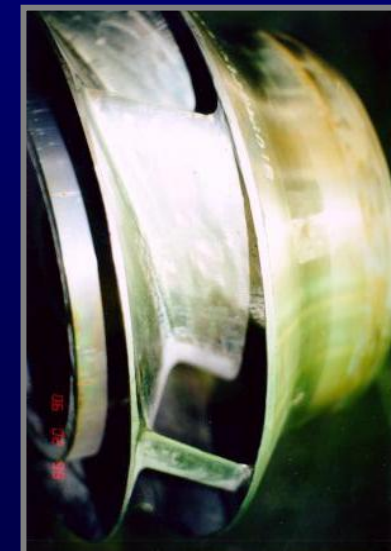
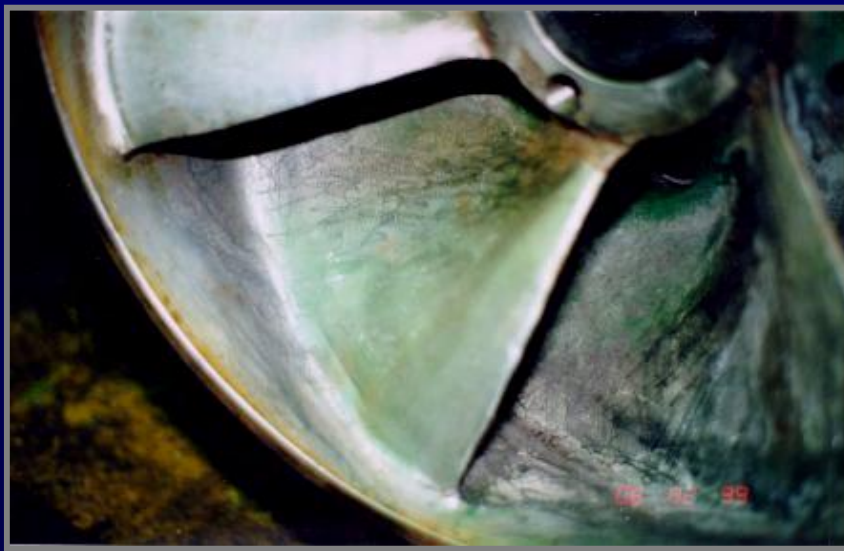

**MAY 1997 - FEB 2000 – 3 YEARS IN SERVICE**



# RESULTS – MAINTENANCE REDUCTION

## PUMP OVERHAULS / REPAIRS

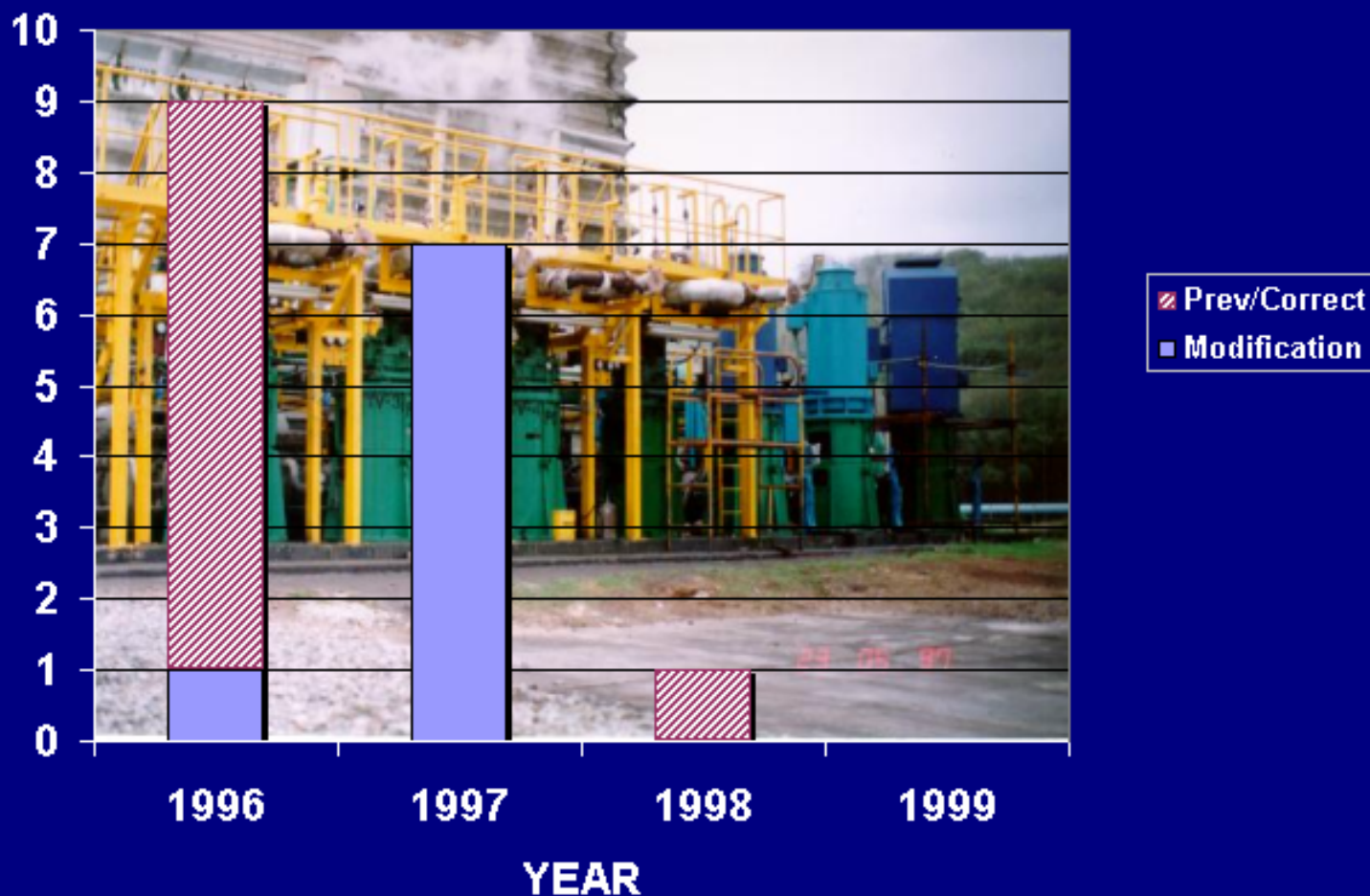



# **CONCLUSIONS**

---

- ▶ **Pumps successfully upgraded by simple impeller-bowl modifications.**
- ▶ **Better metallurgy in pump impellers, together with smooth vane surface finish and operation close to the BEP, provided significant service life improvement in conditions where cavitation-corrosion damage can develop.**
- ▶ **Stand-testing of modified pumps allowed reliable performance adjustment for trouble-free start-up at the field .**
- ▶ **Expected performance of original equipment should have been overrated.**

# ***LESSONS LEARNED***

---

- ▶ **Evaluate the possibilities for improvement of existing equipment before considering their replacement .**
- ▶ **Simple solutions to the root cause of problems may provide good results and considerable savings .**
- ▶ **Equipment to be delivered on turn-key projects must have specifications for procurement, written by the user or on a user basis, in order to ensure long-term, trouble-free operation and reduced maintenance costs.**
- ▶ **Choose a reliable supplier as “partner.”**

# REFERENCES

---

- ▶ Mc. Caul, Colin. ***An Advanced Cavitation Resistant Austenitic Steel for Pumps***. Corrosion 96, The NACE International Annual Conference and Exposition. Paper N° 415, 1996.
- ▶ Bloch, Heinz P., Geitner, Fred K. ***Machinery Failure Analysis and Troubleshooting***. 2nd Edition. 1993. Page 44-46. Gulf Publishing Company
- ▶ Bloch, Heinz P. ***Pump Reliability Improvement Program***. Pump Failure Reduction Programs. PRIME Seminar notes
- ▶ Pfleiderer, Carl. ***Bombas Centrífugas y Turbocompresores***. Editorial Labor, 1960.

***THANK YOU !***