

# RELIABILITY IMPROVEMENTS TO A HIGH PRESSURE, HIGH TEMPERATURE, THIRTEEN STAGE CHARGE PUMP

by

Dave A. Johns

Senior Engineer, Mechanical Equipment

Shell Oil Company

Norco, Louisiana



received a B.S.M.E. from Louisiana Tech University.

David A. Johns is a Senior Mechanical Equipment Engineer for Shell Oil. He is responsible for the Mechanical Equipment and Technical Staff in the Olefins and Utilities sections of Shell's Norco, Louisiana, manufacturing complex. Prior to joining Shell in 1990, Mr. Johns was Field Manager, Service and Engineering with Elliott Company. During the years Mr. Johns spent with Elliott, he held various positions in field service and shop engineering. Mr. Johns

Table 1. Pump Data.

TYPE	PACIFIC HMIJ, 8 in
DESIGN	HORIZONTAL, 13 STAGE, VERTICAL SPLIT, BETWEEN BEARINGS, BARREL TYPE
SUCTION PRESSURE	100 psig
DISCHARGE PRESSURE	2500 psig
PUMPING TEMPERATURE	750°
PUMPAGE	HOT OIL
SPEED	3600 rpm
DRIVER	3000 hp ELECTRIC MOTOR
FLOW	2000 gpm

## ABSTRACT

Reliability of a high pressure charge pump has been a problem for over 20 years. Unplanned unit outages and sometimes fires accompany pump failures. This paper details the joint effort of the OEM and the user to resolve the problems associated with design and installation.

The end result is a pump that has run for three years without incident, without performance decrease, and without vibration increase.

OEM recommended hardware improvements include:

- Metal to metal head to case fit
- Larger diameter stepped shaft with split rings
- Spiral groove wear rings and bushing
- Remachine bearing housings
- Interference fit bundle

User's specified changes include:

- Metal bellows seal
- Integral impeller wear rings
- Hard coating wear rings and bushings
- Provision for thermal growth control
- Reduction of pipe strain

The lessons learned from this case history can be applied to pumps of any manufacture to resolve chronic reliability problems.

## INTRODUCTION

The Hydrocracker Unit at the Norco Manufacturing Complex depends on a single (unspared) pump to charge oil to the unit. General data for this pump are presented in Table 1. Pump assembly drawing is shown in Figure 1.

Since installation in 1965, this pump has had a record of poor reliability with several seal failures resulting in fires. Previous

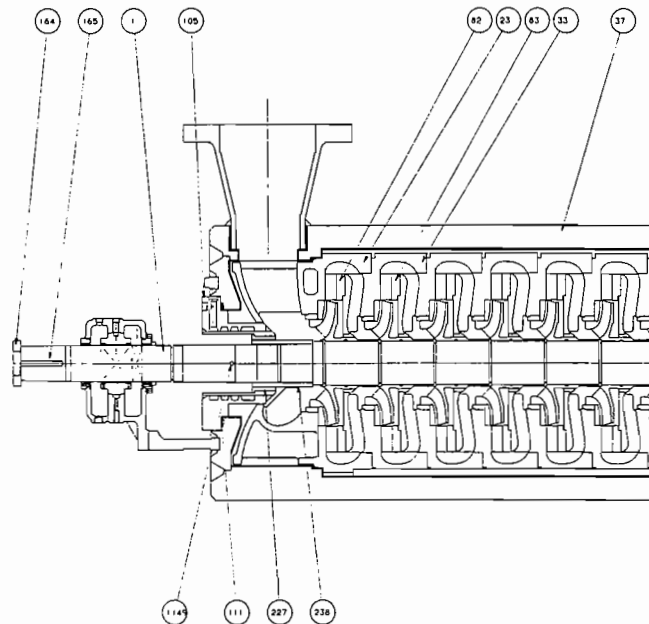

Figure 1. Pump Assembly.

attempts to improve reliability have made some progress, but the pump was never able to run from turnaround to turnaround. The majority of the seal failures were on the coupling end and most of the failures occurred during pump startup.

Several options to improve the pump's reliability were considered:

- Replace the existing pump with a new barrel pump.
- Add a spare pump.
- Install a volute type pump.
- Modify the existing pump with vendor recommended hardware improvements.

After reviewing the options, the decision was made to modify the existing pump due to the following attractive features:

- It was the lowest cost option.
- No piping or pump baseplate modifications were required.
- Manufacturer recommended changes had a proven track record at other facilities.

#### Modification Scope

Since this pump is unspared, all of the upgrade work had to be performed during a scheduled unit turnaround. In order to minimize the downtime required, the pump's spare inner case and rotor assembly was sent to the manufacturer's repair facility for modification prior to actual unit shutdown. In addition, changes that were to be made on the pump case and bearings were closely coordinated with the manufacturer's shop in advance of shutdown.

Manufacturer's recommended and installed hardware improvements included:

- Metal-to-metal head to case fit.
- Larger diameter shaft, stepped at each impeller fit, with shrink fit impellers located by split rings and double keys for each rotor component.
- Tapered locknut balance piston.
- Kingsbury LEG thrust bearing.
- Spiral groove wear rings and bushings.
- Remachined bearing housing horizontal split line to remove gasket.
- Interference fit bundle (covers).

User's specified changes included:

- Metal bellows mechanical seal.
- Integral impeller wear rings.
- Hard coat rotating wear rings and bushings.
- Provisions for thermal growth control.
- Reduction of pipe strain.

#### SHOP/BUNDLE MODIFICATIONS

Upgrade of the spare bundle was to be accomplished in the manufacturer's shop to lessen the amount of time required for the pump upgrade during the actual turnaround. As it turns out, extensive repairs were required to the existing bundle before the upgrade work could begin.

- New impellers were needed due to the large amount of welding required to incorporate the integral impeller wear rings.
- The intermediate covers required extensive weld repair to return all dimensions to original specifications. This was because previous bundle repairs had included true cutting which adversely affected all of the bundle's axial dimensions.

Once the above repairs were complete, the real bundle upgrade work could begin.

#### Metal-to-Metal Head to Case Fit (Figure 2)

The discharge head serves the following functions:

- Seals the pump's discharge end and closes the pump's casing.
- Locates the bundle axially and radially.
- Positions and supports the thrust end bearing housing, the stuffing box, the balance piston seal, discharge diffuser and the gland plate.

The head to case joint has been a leakage area in the past.

The original pump assembly specifications called for clearance between the pump head and casing. Designers of the pump, in an effort to maintain rotor to case alignment, also wanted the head parallel to the case within 0.002 in. Asking a machinist to tighten 24, 2.0 in studs holding a 500 lb chunk of steel and keep the surfaces parallel within 2.0 mils is like winding a Rolex with an impact wrench. This is a challenging task under ideal laboratory conditions, and nearly impossible under field conditions. The metal to metal case fit has several advantages:

- Easier and faster assembly.
- Chance of leak is minimized.
- Proper bolt torque is more easily obtained.

The modification required machining the discharge head, the mating surface of the casing, and the inner discharge head. All other machined faces and bores were welded and remachined so that the entire case was brought back to factory specifications.

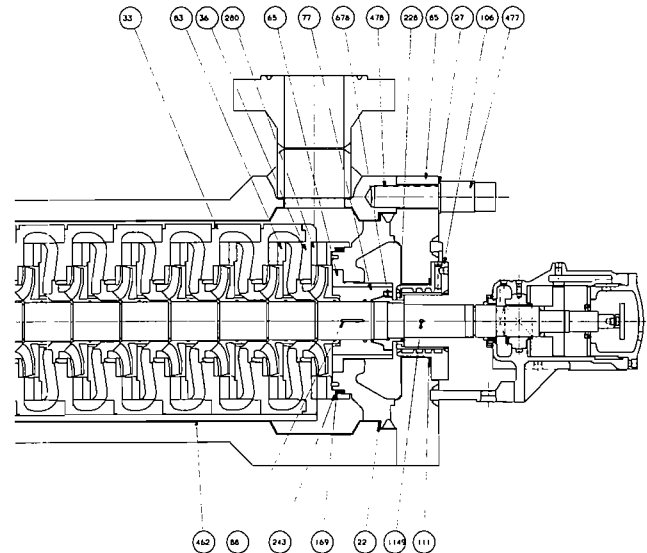

Figure 2. Discharge Head Assembly.

#### Stepped Shaft With Double Keys and Split Rings (Figure 3)

The original shaft was the same diameter from the first to the last impeller, with each impeller driven by a single key. Proper axial impeller position was established by a shaft shoulder on one end with impellers and sleeves stacked from this shoulder.

This type of rotor construction has several disadvantages:

- Galling probability during rotor assembly increases with the length of same diameter shaft that impellers and sleeves have to pass over.
- Axial stack-up errors are likely, because everything is referenced from one point, the shaft shoulder.
- Difficulty maintaining rotor straightness, which depends upon the squareness of the impeller hub and spacer sleeve faces when the components butt together.

The new design shaft has several features to ease assembly and increase stack-up accuracy. Starting from the first stage, the shaft diameter under each impeller is progressively smaller. Therefore, the impeller has clearance on all fits except the mounting fit. Each shrunk fit impeller is individually located by split rings which fit into machined grooves on the shaft. The impeller is machined to retain the rings. The sleeves are fabricated as part of the impeller instead of each being a separate item.

The manufacturer performed a rotordynamics analysis of the new design to predict stability. The model predicted a very stable rotor, which has been verified in three years of operation.

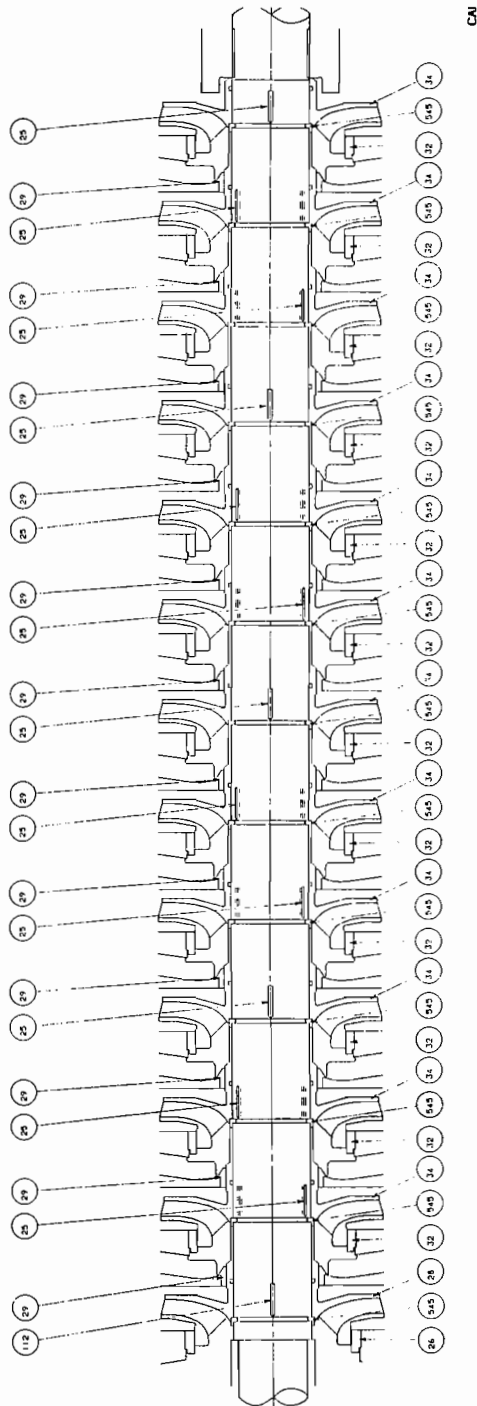

Figure 3. Rotor Assembly.

*Spiral Groove Wear Rings and Bushings*

Standard wear rings attached to the impeller by tack welds or set screws were originally supplied. These separate impeller wear rings tend to crack and come off of the impeller if suddenly heated, such as during mechanical contact or the pump running dry. These loose metal parts then go on to cause further damage in the pump. The following modifications were made to minimize the potential damage to the pump due to wear ring touch off or failure.

- Both the impeller eye and shaft sleeve wear rings were made integral with the impeller. This eliminates the possibility of the ring coming loose or breaking. The impeller has sufficient material to allow recutting and making case rings undersize. Wear ring renewal after one recutting requires weld buildup of the sealing areas and remachining.

- The rings and mating bushings were made with spiral grooves on the surface instead of the typical smooth surface (Figure 4). The grooves in the rotating part are in the opposite direction of the grooves in the stationary part. The counter spiral grooves have two benefits:

- If a gall were to develop, the grooves provide a path for the material to exit the seal area, thus minimizing damage to the wear rings.

- The counter spiral grooves provide a better seal, thus increasing efficiency.

- The rotating wear rings and balance piston were coated with tungsten carbide to create a greater surface hardness differential between the rotating and stationary parts.

Due to the long flexible rotor, there is a high probability that mechanical contact will occur between close radial clearance parts at some point in the pump's life. The hard coating allows a brief contact without removing metal from the rotating element.

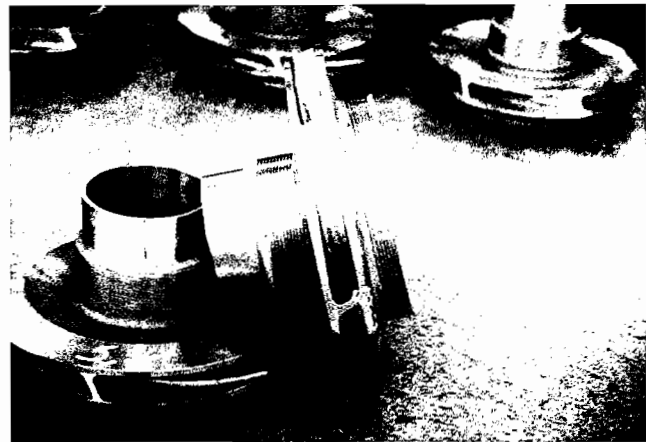

Figure 4. Impeller with Counter Rotating Spiral Grooves.

*Interference Fit Bundle*

Manufacturing tolerances on the original bundle could add together to produce loose fitting covers. Assembly and disassembly of loose fitting parts is easier but maintaining concentricity throughout thirteen stages is near impossible (Figure 5). Since weld buildup was already required to correct the axial spacing problems, additional metal was added to the register fit area on each intermediate cover. All fits were turned parallel and concentric to original specifications. The rabbit fit was changed to produce a one to four mil interference, ensuring that all stationary hardware is concentric.

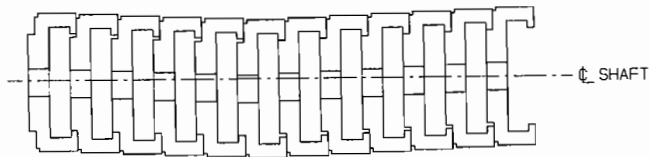

Figure 5. Cumulative Effect of Loose Fit Covers.

#### Remachine Bearing Housing Horizontal Split Line

The pump's radial bearings are spherically seated babbitt lined sleeve bearings (Figure 6). Original design required the bearing crush to be adjusted by varying the gasket thickness on the bearing housing horizontal split line. This is a time consuming task and end results were of questionable accuracy. Present day precision bearing manufacturing techniques eliminate the need for an "adjustable" bearing housing split line. Elimination of the split line gasket required machining of the horizontal split line and reboring of the spherical seat. After machining, the housings were centered and doweled into position on the pump case.

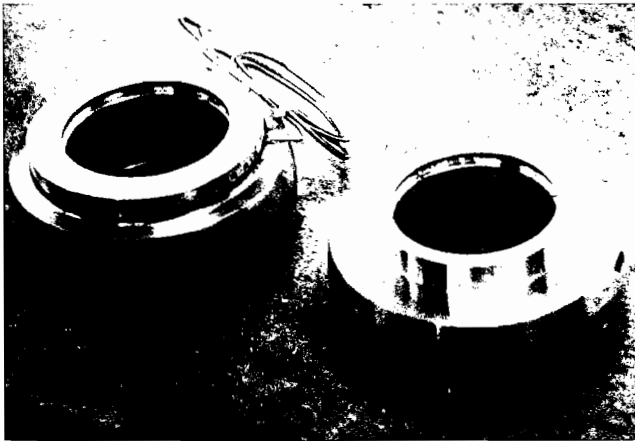

Figure 6. Spherically Seated Babbitt Lined Journal Bearings.

#### Seals

The frequency of seal failures allowed opportunity to test many seal variations. However, the seals' poor performance was not entirely due to seal design. The casing distortion and pipe strain (which are discussed below) were the biggest factors in limiting seal life. The seals selected for the upgrade were a metal bellows type with graphfoil gaskets. Axial position is established through L shaped split rings that are ground at assembly to properly locate the seals. The rotating sleeve is key driven and the seal is friction driven to eliminate set screws.

Seal flush piping is per API Plan 21 for normal pump operation. When this flow is not available, flush is provided from an external source per API Plan 32. Cooling is provided by a bank of natural convection fin tube exchangers and four shell and tube water cooled exchanges (Figure 7). Seal flush flow is maintained at 4.0 to 5.0 gpm per seal, via manually controlled needle valves. Desired temperature range is 200 to 250°F. The seals are quenched with low temperature steam.

#### FIELD/CASE MODIFICATIONS

Everything was going per plan until three weeks before the turnaround, when a power failure caused the unit to shutdown. Restart of the pump was accompanied by a seal failure and fire.

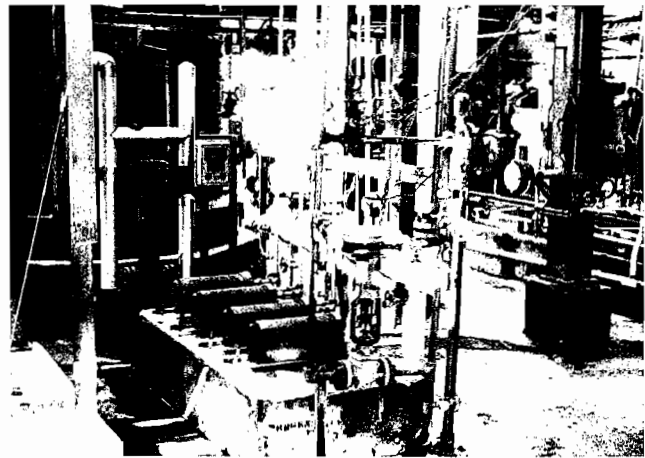

Figure 7. Water Cooled Seal Flush Coolers.

Additionally, the pump's drive motor was damaged severely enough to require replacement. At this point, the decision was made to start the unit turnaround three weeks early.

#### Pump Removal

This was the first time the pump case had been removed since original installation and upon disassembly and further inspection the following damage was found:

- The hold down bolts and dowels were bent.
- The coupling end (suction end) centering pin was stuck to the case, attachment welds had failed (Figure 8).
- The supports for the centering key and pin were bent.
- Suction and discharge flanges were out of square with centerline.

#### Existing Thermal Growth Control

Based on the above observed damage, it was obvious that the pump's existing provisions for thermal growth control were inadequate. The existing thermal growth control scheme included:

- One centering pin at the bottom of the coupling end (Figure 9).
- An axial key under the thrust end (Figure 10).
- Both the centering pin and the axial key had the female part on the case and the male section mounted on the pump base.

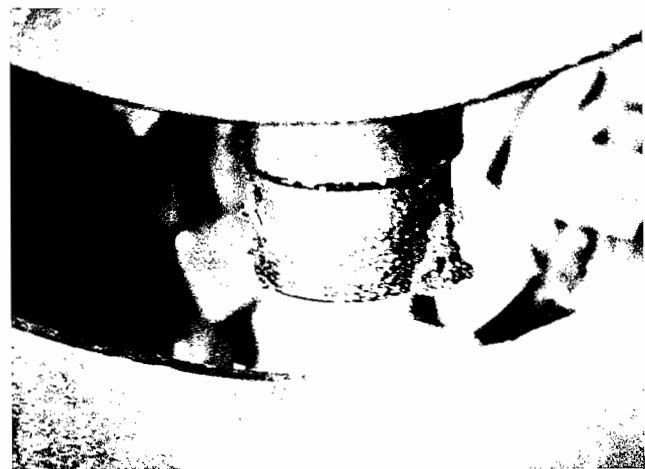

Figure 8. Coupling End Centering Pin Stuck to Case.

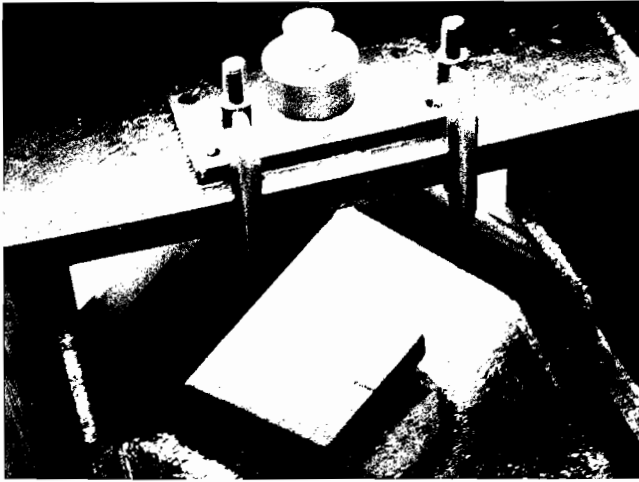

Figure 9. Typical Coupling End Centering Pin.

- The centering pin and axial key were tack welded to a piece of 4.0 in structural channel that was in turn welded to the pump's support legs.
- Full length water cooled pedestals support four mounting pads on the pump's horizontal centerline.
- The coupling end horizontal support pads were dowelled.
- Sleeves were installed in the outboard pads to allow the feet to move axially and radially. This was accomplished by making the sleeve long enough to provide clearance between the bottom of the hold down nut and the top of the pad.

Thermal growth of the pump was calculated using equation (1) to verify the observations and determine the magnitude of the problem.

$$\Delta L = \Delta T \cdot \alpha \cdot L \tag{1}$$

where

- $\Delta L$  = thermal growth (in)
- $L$  = total cold length (in)
- $\Delta T$  =  $T$  (of Product) -  $T$  (ambient) ( $^{\circ}F$ )
- $\alpha$  = coefficient of thermal expansion ( $7.23 \times 10^{-6}$  in/in/ $^{\circ}F$ )

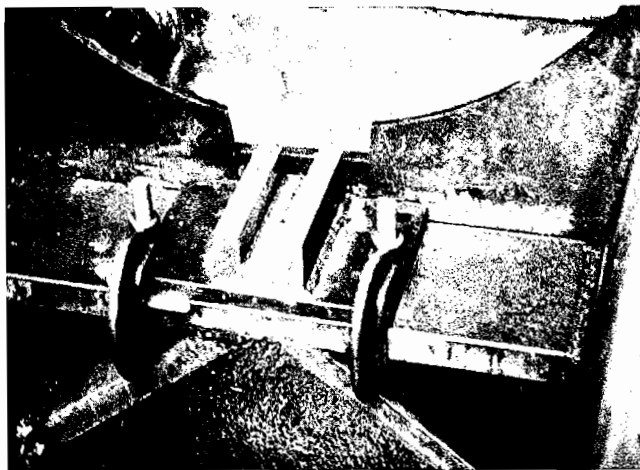

Figure 10. Typical Discharge End Centering Key.

For this case:

Axial growth =  $680^{\circ}F \times 7.23 \times 10^{-6}$  in/in/ $^{\circ}F$  85 in = 0.418 in (Figure 11)

Radial growth from the center =  $680^{\circ}F \times 7.23 \times 10^{-6}$  in/in/ $^{\circ}F$   $\times$  14 in = 0.069 in (Figure 12)

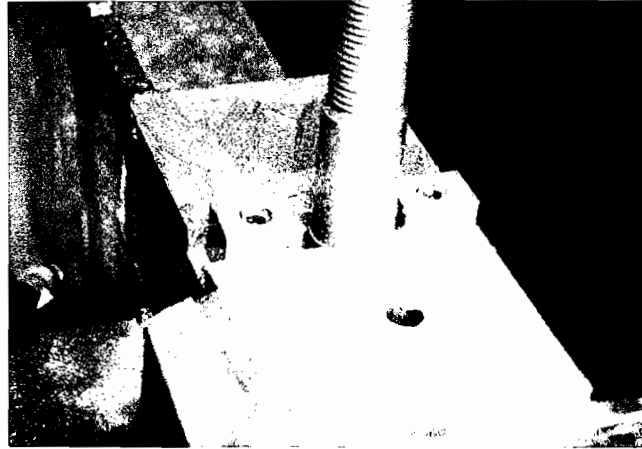

Figure 11. Calculated Axial Thermal Growth.

The calculations identified two areas of concern. The axial thermal growth was more than the clearance in the outboard bolt holes; this is the reason these bolts were bent. Since the coupling end feet are dowelled and not allowed to grow, the radial thermal growth forced the pump to distort in an oblong manner. Clearly, the dowels were performing their task of maintaining alignment, but were also causing unhealthy distortion. The question of how to maintain alignment while allowing the case to grow thermally without distortion was answered by borrowing technology from the steam turbine industry.

*Thermal Growth Control in Steam Turbines*

Steam turbine designers accept the physical law that metal expands when heated. Thermal growth cannot be prevented, but it can be guided or controlled. If the thermal growth design features of a steam turbine are compared to those of a hot pump, several different philosophies are apparent. Turbines are designed to guide the thermal growth in such a way that:

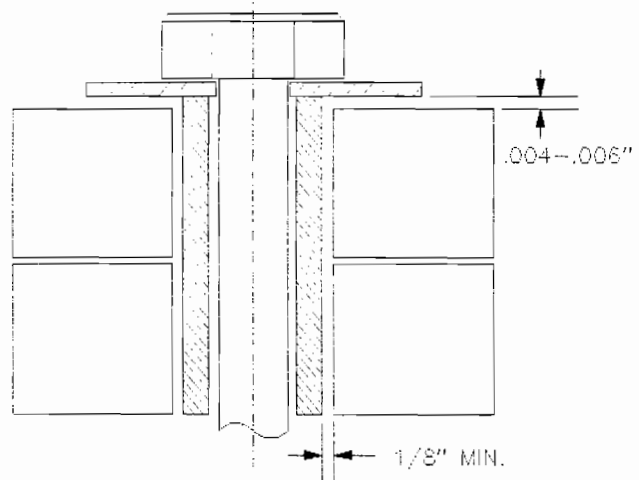

Figure 12. Calculated Radial Growth.

- Coupling alignment is maintained.
- The turbine is free to move within its guides.

The primary consideration, however, is to guide the casing and rotor growth such that contact between the case and rotor is prevented, especially during thermal transients. Pump designers have not given thermal growth much consideration until recently.

Typical steam turbines are centerline supported with the coupling end rigidly supported. This forces axial casing growth in the outboard direction. The rotor fixed point (the thrust bearing) is opposite the casing fixed point. As the rotor warms, it grows toward the coupling, but the case grows away from the coupling. Therefore, the relative position of the rotor and case remain the same. Radial keys in the horizontal and bottom center guide the radial movement while keeping the case on center. The steam end is allowed free movement along the axial centerline and also guided in the radial direction. This is accomplished through a variety of hardware: wobble feet, sliding keys or trunions. Additionally, the hold down bolts have an internal sleeve that prevents the bolts from tightening against the sliding feet.

Comparing the thermal growth of a similar size turbine to the subject pump, the turbine actually grows less, yet it has a more elaborate system to guide growth. Common steam conditions are 750°F inlet and 350°F exhaust, whereas the pump sees 750°F from end to end.

The approximate axial growth of a similar size turbine would be:

$$\Delta T = \frac{750^{\circ}\text{F} + 350^{\circ}\text{F}}{2} - 70^{\circ} = 480^{\circ}\text{F}$$

Axial growth =  $480^{\circ}\text{F} \times 7.23 \times 10^{-6} \text{ in/in}^{\circ}\text{F} \times 85 \text{ in} = 0.295 \text{ in}$

#### *Thermal Growth Modifications*

The following modifications were made to the pump to make it control thermal growth more like a steam turbine.

- Radial keys at the coupling end horizontal supports
- Strengthened supports for existing bottom centerline pin and key
- Slotting of outboard end feet
- Sleeving of all four hold down bolts to allow vertical clearance
- Removal of dowels in support feet

#### *Radial Keys*

The radial keys (Figure 13) are one in square and centered with the existing bottom pin. Machining of the case-half keyway was relatively simple, since the case was already in the machine shop. Indicating the case showed the centering pin and the hold down bolt holes to be on the same plane. The base-half keyways were field machined after the pump was returned to the field. The pump was positioned on the base, and the key location was transferred to the base. The pump was removed and base key ways machined. The keys are made of 17-4 stainless steel material and installed with line to line contact in the base, with approximately 4.0 mils in clearance in the pump.

#### *Support Feet*

The outboard support feet were slotted axially to allow sufficient freedom of movement. All four foot bolt holes were enlarged to allow clearance for the sleeve and radial growth. This was done while the pump was in the machine shop.

Spot facing for the washer was also a machine shop task. After leveling and aligning the pump, sleeves were fabricated to allow 5.0 mils vertical clearance between the hold down washer and the pump feet (Figure 14) to allow unrestricted movement of the feet.

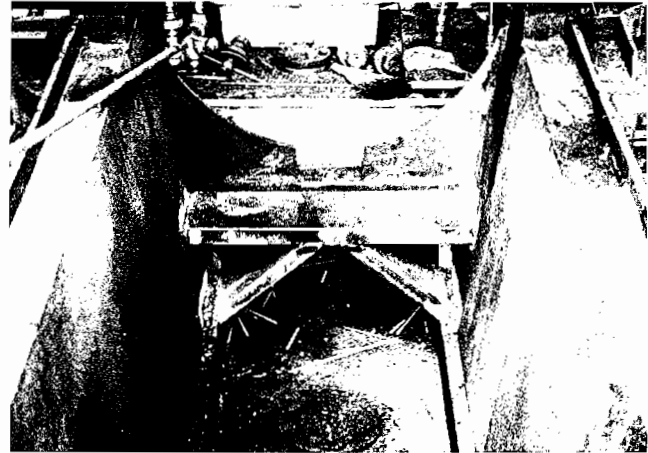

Figure 13. Radial Keys Installed in Pump Pedestal.

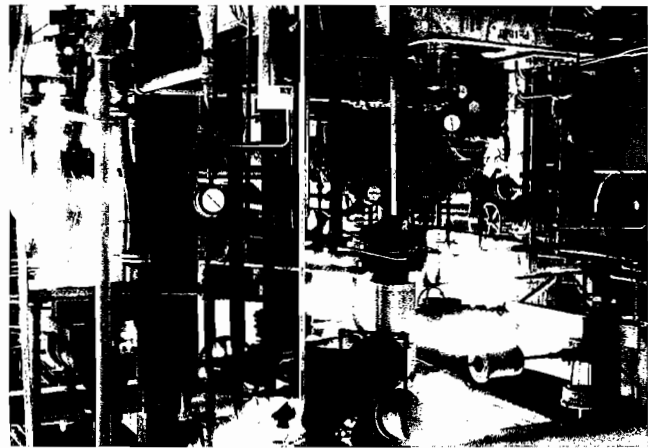

Figure 14. Vertical Clearance of Hold Down Bolts.

#### *Axial Key and Centering Pin Support*

Design requirements for the new supports were:

- Allow quick installation because startup was fast approaching.
- It must be strong because the previous beam had bent.
- Use available material.
- Keep it level to avoid binding.
- Make the keys removable for future maintenance.

The support for the axial bottom key and centering pin was changed from a single piece of structural channel to a stiffer design consisting of 1-1/2 in x 4 in steel plate (Figure 15). The horizontal plate was carefully fitted and leveled with a machinist's level and its position was continuously monitored throughout the welding process. Support gussets were also carefully fitted from the center of the new beam to the pump support rails.

The old centering hardware was tack welded to the support beam while the new hardware is made such that it is flange mounted to the beam. Installation of the bottom centering hardware was a multistep process.

- Install pump, level, center on new radial keys.
- Center bottom pin and key, clamp to support beams.
- Remove pump.
- Transfer bolt locations to beam, drill and tap.



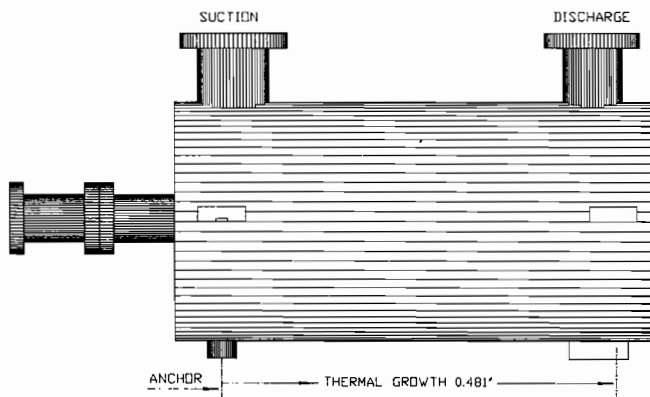

Figure 17. Location of Horizontal Spring Supports.

showed very little change. After the system reached operating conditions, the spring cans were adjusted to calculated hot operating loads.

#### Driver Replacement

Concurrent with the pump work, a new drive motor was also installed. The original drive motor developed a high synchronous vibration after the pump failure. Repair of this motor was not successful, however, a replacement motor was available "off the shelf" that met the user's requirements. The only difference was the new motor was 18 in shorter in height.

The following steps were performed to adapt the new motor to the old base:

- Voids in the existing base were pressure grouted.

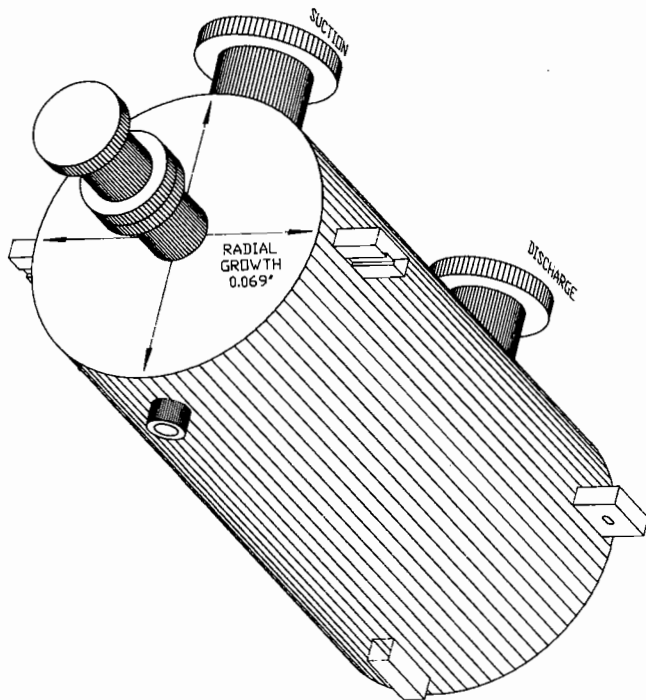

Figure 18. New Motor Base Adapter.

- An 18 in high adapter was fabricated using 1.0 in plate. Internal gussets and cross bracing made the adapter very rigid. One in thick pads were added to support the motor (Figure 18).

- The adaptor was welded to the existing base.
- The adaptor was filled with epoxy grout.
- Motor mounting pads were field machined level with 0.125 in allowance for shims.
- The motor was positioned on the base and mounting holes located.
- Hold down bolt holes were drilled and taped.
- Final alignment was performed.

#### SUMMARY

##### Modifications

- Pipe stress reduction through the addition of horizontal and vertical spring supports.
- Thermal Growth control through the addition of Radial and Axial casing guide keys.
- Interface fit covers
- Stepped, split ring shaft
- Remachine journal bearing housing to eliminate split line gasket
- Metal to metal head to case fit.
- Hard coated spiral groove wear rings and bushings.
- Integral impeller wear rings.
- Rotating metal bellows seal
- LEG Thrust bearing taper lock balance drum.

##### Benefits

- Reduction of nozzle loads which were causing casing distortion.
- Elimination of casing distortion caused by thermal growth.
- Ease and accuracy of assembly.
- Accuracy and consistency of internal alignment.
- Less damage if rub occurs.
- Eliminates wear ring breakage.
- Field proven reliability.
- Latest thrust control technology.

#### CONCLUSIONS

This pump has operated without incident for the past three years. Shaft vibration has remained at 0.2 to 0.3 mills since modification revamping. One unexpected benefit is a dramatic decrease in the operating noise level. Prior to the upgrade, the pump had a distinctive roar. Now its only sound is from the motor cooling fans. Performance has not changed, even though the unit has been through at least 10 start cycles. Startups prior to the revisions were approached by operators with much apprehension. Fire fighting equipment was strategically placed around the pump and the emergency response team was put on alert. Now, closely following established operating procedures, the pump is started with no more concern than any other pump.

All modifications made the pump more like a piece of turbomachinery rather than a common ordinary pump. The metal-to-metal head fit, stepped shaft, integral wear rings, and the metal bellows seal were much needed product improvements. However, these modifications would have been destined for failure had not the pipe strain and thermal growth problems been addressed.

#### ACKNOWLEDGEMENTS

The author wishes to acknowledge John Bertucci and Andy Gallien of Shell Oil Company; and Terry McGuire, John Holland, and Ralph Richard of Ingersol-Dresser Pump.