

REBUILDING PROCESS PUMPS TO COMPLY WITH FUGITIVE EMISSIONS STANDARDS

by

Stephen C. Rossi

Principal Engineer

Tosco Refining Company

Martinez, California

and

John B. Cary

Manager, Maintenance Services

ERIN Engineering and Research, Inc.

Walnut Creek, California



Stephen C. (Steve) Rossi is Principal Engineer for rotating machinery with Tosco Refining Company, a Division of Tosco Corporation. He rejoined the Tosco Refining Company to direct the engineering effort for their Fugitive Hydrocarbon Emission Project in 1992. Mr. Rossi returned to Tosco after eight years at Chevron as a Mechanical Equipment Consultant on pumps, turbines, engines, and compressors. Earlier in his career, he

also worked as a Reliability Engineer for Pacific Gas and Electric Company on their gas transmission systems, specializing in engine compressors and engine protection systems.

Mr. Rossi holds a B.S. degree (Mechanical Engineering) from San Jose State University (1978). He is a registered Professional Engineer in the State of California.



John B. Cary consults in the area of reliability improvement and is currently a Manager in the Maintenance Services unit for ERIN Engineering and Research, Incorporated, in Walnut Creek, California. Mr. Cary has over 20 years experience in the hydrocarbon processing and petrochemical industry, responsible for reliability improvement programs involving all types of mechanical equipment. His expertise includes performance

enhancement for individual pieces of equipment, development and implementation of comprehensive plant wide initiatives, along with machinery specification, selection, installation, and startup.

Prior to joining ERIN, Mr. Cary was Reliability Superintendent for the Tosco Refining Company. Mr. Cary is a 1974 graduate of Columbia College and received his B.S. degree from the University of San Francisco. He has authored and presented several technical papers for the Turbomachinery Symposium, first International Turbomachinery Maintenance Congress, National Petroleum Refiners Association, and several trade publications. He is a member of the Turbomachinery Symposium Advisory Committee, Vibration Institute, and Pacific Energy Association.

ABSTRACT

Most states have adopted regulations that limit fugitive hydrocarbon emissions from mechanical seals in centrifugal pumps. In California, limits as low as 100 ppm have been imposed. Users are faced with few choices to meet these strict standards, and have turned to dual seals and sealless pumps to comply. Many have found that current fugitive emission limits can be met with *single seals* by careful attention to detailed retrofit and repair procedures. Discussed herein are the rigors required to successfully rebuild, maintain, and operate pumps—in most cases with a *single seal*. These techniques also enhance pump reliability and have been applied to over 100 pumps in harsh refinery environments.

INTRODUCTION

Pump History at Avon

The Avon Refinery is over 80 years old. In 1913, crude oil pipe stills were built by a group of San Joaquin Valley oil producers on the Carquinez Straits near Martinez, California. Shortly after building a wharf for receiving the crude oil, they commenced construction of what is now the Avon refinery at the current location a few miles away.

The oldest operating plants date back to the late 1930s. Several plants were built at the onset of WW II to support the defense effort. These plants utilized high speed centrifugal pumps almost exclusively. New plants have been added every decade since, but the average age of a centrifugal pump for the whole facility is nearly 20 years.

Pumps of almost every type were installed over the years. Many were converted from packing to mechanical seals (Figure 1) without regard to shaft flexibility, operating point, etc. Over the years, poorly assembled and maintained auxiliary piping and flush systems were added, modified, or abandoned. In addition, unclear or nonexistent operating procedures left operators to "use their judgment." These factors contributed to poor pump/seal reliability.

Evolution of BAAQMD Regulations for Pumps

In the early 1970s the California Air Resources Board (CARB) mandated emissions standards for refineries. Two regional agencies were formed to monitor enforcement of the new standards—the Bay Area Air Quality Management District (BAAQMD), and the South Coast Air Quality Management District (SCAQMD). These agencies were also authorized to develop compliance standards for their jurisdictions. These

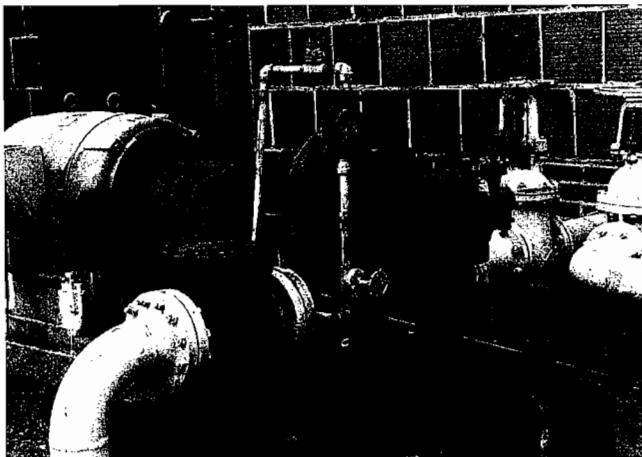

Figure 1. Typical Pre-Upgrade Pump Installation.

standards have historically been much more stringent than Federal EPA standards.

The first hydrocarbon emissions standards for pumps limited release of volatile organic compounds (VOCs) to 10,000 ppm (parts per million), expressed as methane. The BAAQMD also required no less than quarterly monitoring of pump seals and detailed record keeping. Fifteen days were allowed to repair pumps that were found to be over the emissions limit. The equipment could not be returned to service until the emissions limit was met. These limits were attained, in most cases, by replacing mechanical packing with single pusher-type shaft mounted mechanical seals.

As pumps were brought into compliance, the regulators began to "ratchet down" (their term!) on refiners. The regulation became increasingly stringent and, beginning in 1993, requirements went into effect regulating the percentage of equipment that could continue to operate and be put on a future or turnaround repair list (Table 1).

Table 1. Summary of BAAQMD Regulation for Pumps.

YEAR	LEAK STD	TIME TO REPAIR	% WAITING T/A REPAIR	REMARKS
1992 & prior	10,000 ppm	15 days	no limit	
Jan. 1, 1993	1,000 ppm	minimization in 24 hours, repair in 7 days	10%	Spared equip. may not be on T/A list
July 1, 1993	same as above	same as above	same as above	Nat Gas added
Jan. 1, 1995	same as above	same as above	same as above	Methane
Jan. 1, 1997	500 ppm	same as above	1%	Nat Gas added

As these emissions standards went into effect, it became more difficult—and in some cases impossible—to maintain emissions levels in older style pumps. Slender shafts and long spans between bearings created too much shaft deflection at the seal faces. Small seal chambers and inadequate clearances added to the difficulty of retrofitting with modern mechanical seals. At the same time, seal technologies were evolving. Cartridge mounted seals and requirements for larger seal chambers drove the decision to embark on a major fugitive emissions reduction program.

INITIAL APPROACH

In January 1993, the BAAQMD mandated that pump hydrocarbon emissions levels be reduced to 1000 ppm. To meet the more rigorous standards, the refinery reliability group took the lead in identifying the scope of the program, with the intent of turning over the project to engineering for execution. The following approach was used for the initial scoping project:

- Data collection and analysis
- Seal performance testing and pump evaluation
- Vendor selection

Data Collection and Analysis

Data were collected and analyzed to develop a list of pumps requiring work. At this point, the work itself was undefined. Formal fugitive emissions testing was done every quarter. Three years of data on approximately 500 pump seals were analyzed to identify all pumps that had failed their emissions test more than once per year over the three year period. These data were compared with the refinery's bad actors list and prioritized accordingly. Estimates and schedules were developed for the annual budgetary cycle. Other data sources were reviewed to gain a thorough understanding of the scope of the project, including:

- Pump criticality and its effect on the process
- Failure history, including mean time to repair
- Maintenance cost history (total and per repair)
- Bad actors lists
- Hydraulic performance (NPSH and the difference between BEP and actual operating point)
- Future hydraulic requirements

External data were also collected. A benchmarking study was undertaken in other west coast refineries to determine what their experience had been with various seal designs and seal vendors.

Seal Performance Testing and Pump Evaluation

The initial data indicated there were about 150 pumps requiring some degree of retrofitting. The majority of these pumps handled low viscosity products such as propane, butanes, and light gas oils. Based on the scope of the project and the time allotted, the decision was made to standardize on one seal manufacturer. This would save time competitively bidding each seal, and reduce the cost through volume purchases.

Three identical pumps in the same service were chosen for initial seal testing. These pumps were selected because they were in light hydrocarbon service, pumping liquid near its vapor pressure. In addition, the pumps were in a unit that was going into a maintenance turnaround, allowing the opportunity to rebuild all three pumps to identical specifications.

Three pump vendors were invited to participate in the project. They were requested to submit proposals to provide their "best available control technology" (BACT), and were given the specifications for the test pumps. The objectives for the test project were:

- Establish a control technology for light hydrocarbon services to be used on pumps that must be retrofitted to meet future emissions requirements.
- Provide single seals designed to meet stringent emissions standards, avoiding expensive and complicated dual seal installations.
- Document this technology and performance so that it can be applied to retrofits and to new installations.

A *technical support agreement* for the test program was developed for each of the participating seal vendors, stipulating the obligations of each to provide technical support and assistance as a full partner in the seal selection, retrofits, and testing.

Each vendor assigned a field service engineer to participate in the overhaul, installation, startup and field monitoring of the test seal. The test pumps were meticulously overhauled and carefully

installed. The seals were tested over a three month period, with the following data recorded daily:

- Emissions readings
- Suction and discharge pressure
- Pumped fluid temperature
- Vibration (radial and axial)
- Seal flush pressure
- Quench steam flow

Vendor Selection

At the end of the seal trial period, field test data were compared with results of the alliance selection process led by the Purchasing group. Vendor performance was weighed against several pre-established performance criteria, such as degree of technical support, seal performance, response time, level of technical expertise, and experience. Long term alliance agreements were then drafted, budgets prepared, and proposed schedules developed.

PROJECT APPROACH

Project Definition

After defining the breadth of the project, a formal program was initiated to implement the entire scope of work. The program was divided into phases corresponding to annual budget cycles. A project core team was assembled, consisting of a project manager, project engineer, full time vendor technical representative, draftsperson, clerk, mechanical contractors, pump alliance partner, and a buyer from the purchasing department. Various area maintenance and operating personnel were ad hoc participants, depending on the location of the retrofit work.

The charter of the project team was as follows:

- Develop reliable technology for pump emissions control to comply with the BAAQMD 1993 through 1997 emissions limits.
- Implement this technology as proactively as possible and thereby avoid penalties and fines for noncompliance.
- Complete detailed designs required to achieve reliable 1993 and 1997 emissions compliance.
- Provide project management support for all phases of equipment upgrades.
- Develop and evaluate equipment hydrocarbon emissions data to prioritize and schedule optimal cost effective repairs and upgrades.
- Integrate the activities of the project with that of the maintenance and operating departments to minimize disruption to the throughput of the refinery.
- Recommend and coordinate equipment upgrades meant to improve equipment reliability in conjunction with emissions compliance modifications.

Candidate Pump Evaluation

Emission levels were measured on all pumps identified as having potential VOC compliance problems. Qualitative data on all VOC program pumps were surveyed to assess the need for upgrades to the sealing system to meet 1997 regulations.

Pumps found to be above the 1997, 500 ppm limit were considered for possible upgrade. The company's third party contractor for emissions compliance used a data base system to generate queries on all pumps with emissions levels at or above the 1997 limit. Detailed analysis of each pump system produced the following breakdown of anticipated upgrades and replacements (Table 2):

Table 2. Recommended Modifications.

Recommendation	Number of Pumps
Seal Upgrade only	96
Power End Retrofit	45
Complete Replacement	5
No Change	24
Total	170

Proactive Approach to Problem Pumps

A proactive approach was chosen to comply with the BAAQMD regulations. An in-kind, reactive repair program would have increased cost to the company and created major repair back logs when more stringent emissions limits went into effect.

The cost of emissions related pump repairs made in 1992, 1993, and 1994 is shown in Figure 2. In 1994, 40 pumps required emissions related repairs, down substantially from 92 in 1992 and 64 in 1993. The total cost for all repairs during this three year period was over one million dollars.

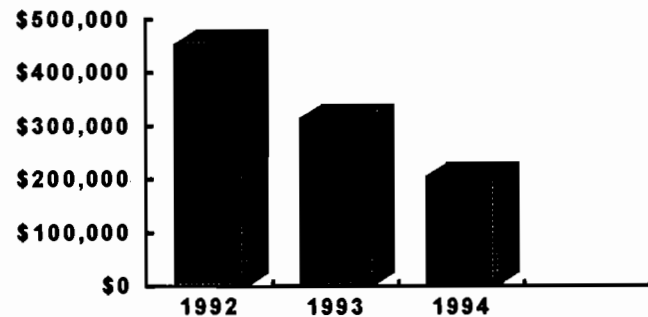

Figure 2. Annual Cost of Emissions Repairs.

The following projections illustrate the potential for savings with a proactive vs reactive approach to emissions compliance. (Repairs were expected to remain constant through 1996, then increase by 50 percent in 1997 when the emission limit is reduced to 500 ppm.)

“Reactive” Approach (in-kind repairs on as needed basis):

1995: 25 emissions repairs per year at \$5000 each	\$125,000
1996: 25 emissions repairs per year at \$5000 each	\$125,000
1997: 40 emissions repairs per year at \$5000 each	\$200,000
TOTAL COST	\$450,000

“Proactive” Approach (continuation of modifications and thermal oxidizer installations):

1995: 25 emissions repairs per year at \$5000 each	\$125,000
1996: 15 emissions repairs per year at \$5000 each	\$ 75,000
1997: 15 emissions repairs per year at \$5000 each	\$ 75,000
TOTAL COST	\$275,000

Savings over this three year period was estimated to be at least \$175,000 as shown in Figure 3. A complimentary maintenance cost savings was also expected due to the increased reliability.

In conjunction with emissions history, mean time between repair (MTBR), and hydraulic performance requirements factors were evaluated.

Experience had shown that in-kind repairs of equipment which failed emission monitoring would, in most cases, not comply with 1997 levels due to pre-existing problems such as pipe strain, unstable foundations, and poor suction conditions. These conditions were corrected as part of the upgrade process. This

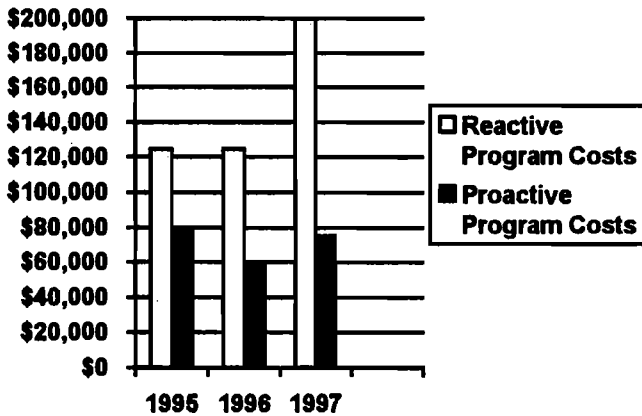

Figure 3. Project Pump Repair Costs.

proactive approach reduced chronic mechanical seal failures and subsequent emissions, improving long term reliability and lowering total life cycle cost of the equipment.

A tremendous effort was devoted to identifying pumps to be included in the program. Data from a number of sources were scrutinized to justify each pump's inclusion. This was an important exercise for a number of reasons:

- To prioritize the upgrade sequence (shortest MTBR to longest MTBR).
- To identify detailed scopes of work and schedule each retrofit to coincide with other refinery activities.

At the end of this exercise, a well defined list of pumps targeted for upgrade emerged. The plan was communicated to all affected refinery personnel and used as the basis document for all project work.

PREPARATION OF SPECIFICATIONS

Pump and Seal Purchase Specifications

The project team immediately set out to establish minimum requirements for pump and seal specifications. A series of meetings was held with both the seal and pump alliance partners, along with company machinery specialists to create project specific specifications. The basis for the specifications was API 610 with clarifications in the areas of fits and tolerances. A draft version of API 682, (Centrifugal Pump Shaft Sealing Systems for Refinery Services; first draft 9/92) was also used for guidance. The intention was to create an environment for the seal that would allow it to function as intended. These specifications were later adopted company-wide.

Examples of Critical Fits

Areas of concern and additional requirements to API 610 are tabled below:

Additional Requirements

- Seal chamber register (radial) to shaft within 0.001 TIR (Figure 4).
- Component match impeller to shaft fit to achieve a goal of 0.000 in tight to 0.001 in loose. (After much discussion, the requirement to component match the impeller to the shaft fit was modified to read: Clearance fits shall be ANSI B4.2-1978 H7/h6.)
- Component match of rolling element thrust bearings to achieve 0.004 in maximum axial float.

- Shaft sleeve bores shall be equal to the maximum diameter of the shaft with a tolerance on +0.0010 in to -0.0000 in.

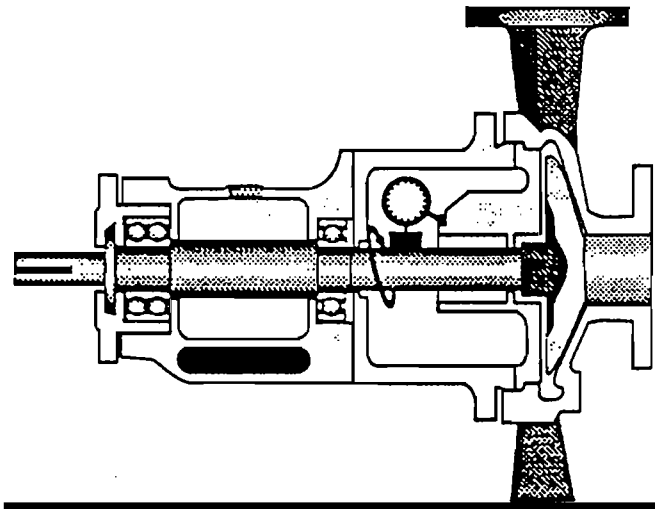

Figure 4. Seal Chamber Register Tolerance.

Modifications

- Squareness of seal chamber face register to shaft axis was reduced from 0.002 to 0.001 TIR (Figure 5).
- Sleeves will have a relief centered axially and the minimum sleeve thickness can be 0.090 in within the relieved area.

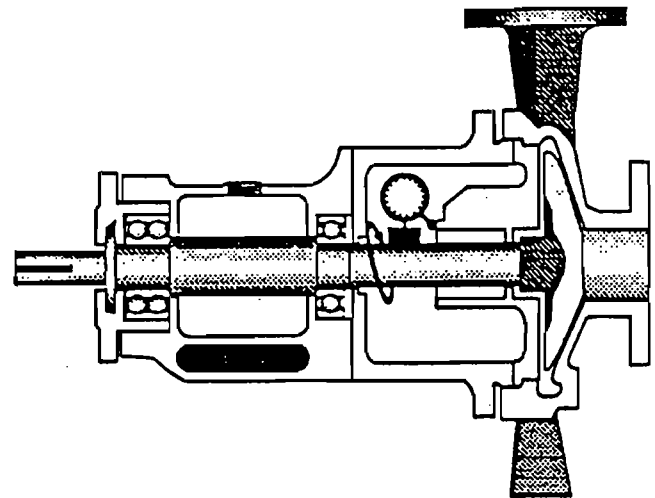

Figure 5. Squareness of Seal Chamber Face Register to Shaft Axis.

It was agreed that these specifications would be the minimum quality level expected.

Repair and Installation Specification

The quality of pump installations varied considerably throughout the plant. Foundation preparation, grout, or lack of grout, piping strain, alignment, and other important variables all varied considerably. No company repair and installation standard existed other than the original equipment manufacturer (OEM) guidelines and a few "rules of thumb." So, the project team created a repair and installation specification. This specification covered setting of new pumps and drivers, rebuilding of pumps, installation of retrofit kits, and seal flush, vent, and drain connections.

Some of the important focus areas addressed in the specification were:

- “As found” pipe strain effects were checked and recorded (Figure 6) prior to pump removal using a laser alignment tool attached to the coupling. These were checked again when final piping connections were made.
- The existing pump base was checked for voids and flatness (Figure 7). Pressure injection grout—and field machining of machinery mounting pads when tolerances are exceeded.
- On nonretrofit pumps, new 17-4PH pump shafts were fabricated and all fits reclaimed to tolerances in the new pump specification.
- All pumps, including retrofits, were fitted with close clearance carbon throat bushings to maintain seal chamber pressure.
- New dynamically balanced, multiple disk spacer couplings with register fits for the hubs and center section were provided on all upgrades.
- Completed pump and seal assemblies were leak tested before field installation. This minimized the need for rework after the pump system was filled with process liquid.

DATE _____
 MACHINIST _____
 APPROVED BY _____
 EQUIPMENT ID _____
 UNIT NUMBER _____

DIS-ASSEMBLY

HOT ALIGNMENT		COLD ALIGNMENT	
	ANGULAR	PARALLEL	
0°			0°
90°			90°
180°			180°
270°			270°
360°			360°

PIPE ALIGNMENT		TORSIONAL DISPLACEMENT	
	ANGULAR	PARALLEL	
L-R			NO DISPLACEMENT ○
F-B			1/4 HOLE ◐
			1/2 HOLE ◑
			3/4 HOLE ◒

LEGEND:
 L-R = LEFT-RIGHT MEASUREMENT
 F-B = FRONT-BACK MEASUREMENT

Figure 6. “As Found” Pipe Strain Record Form.

Support Systems Specification and Selection

Existing piping and seal systems were upgraded. Most of these pumps had screwed connections throughout (screwed connections are potential emissions sources). As part of the upgrades for piping reliability, the following were addressed:

- All screwed connections on the pump casing or process piping were replaced with schedule 160 nipples; the nipples did not

BASE PLATE CONDITION FORM

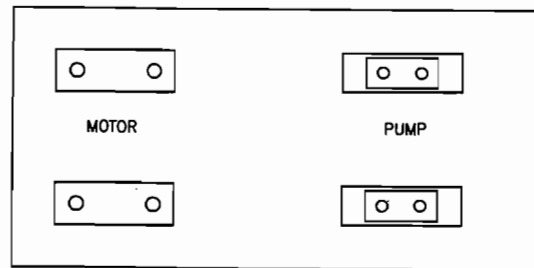
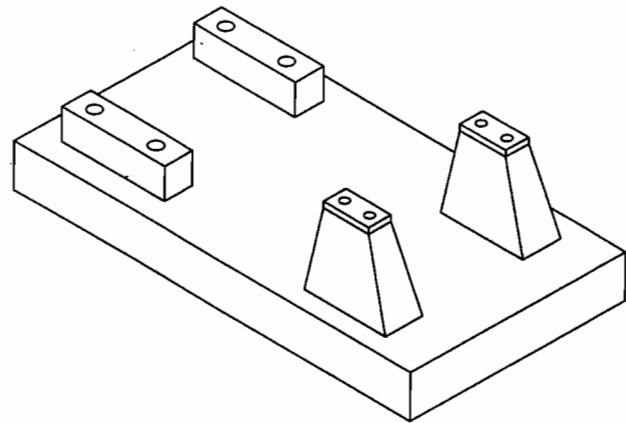

USE THE ABOVE TO MARK ANY AREAS OF CORROSION, VOILDS, OR PITS OF THE BASE PLATE INCLUDING GROUT.
 USE THE FOLLOWING :

- V = VOID
- C = CORROSION
- P = PITS

Figure 7. “As Found” Baseplate Condition.

exceed four inches in length and were gusseted in two planes, seal welded and flanged eliminating screwed connections if possible (Figure 8).

- All tubing connections to the primary seal were 1/2 in 316 stainless steel with a wall thickness of 0.065 in. Smooth radius bent 3/4 in tubing was used for thermosyphon cooling when required (Figure 9).

The final tubing connections (not more than 18 in) were long to reduce seal flange distortion and make installation and removal of the seal easier.

Vent systems were provided on seal chambers in addition to the pump case vents to ensure filling of the seal chamber prior to startup. These venting systems included instructions in the form of a venting procedure tag installed on nearby piping. The venting procedure addressed both seal and pump venting (Figure 10).

Instrumentation

Only essential, critical, or remote and unattended pump seal systems were instrumented. Typically, a level switch on a seal reservoir was the only signal back to a control room. Most installations did not warrant remote readout instrumentation, since the operators were better informed of the general health of the pumps by observing them in person.

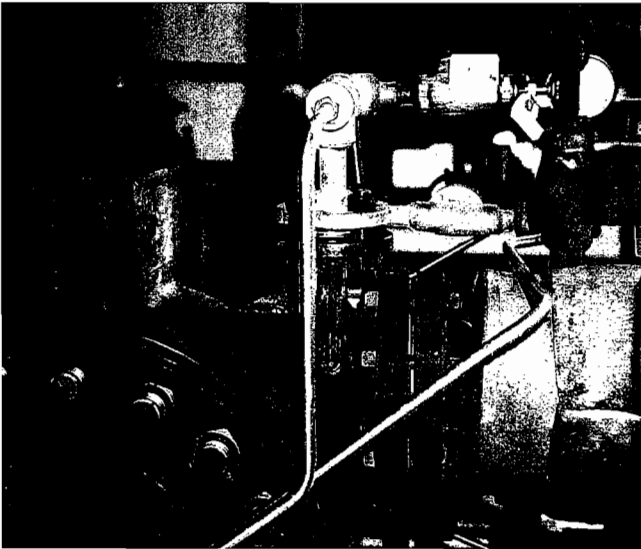

Figure 8. Piping Reinforcement Detail.

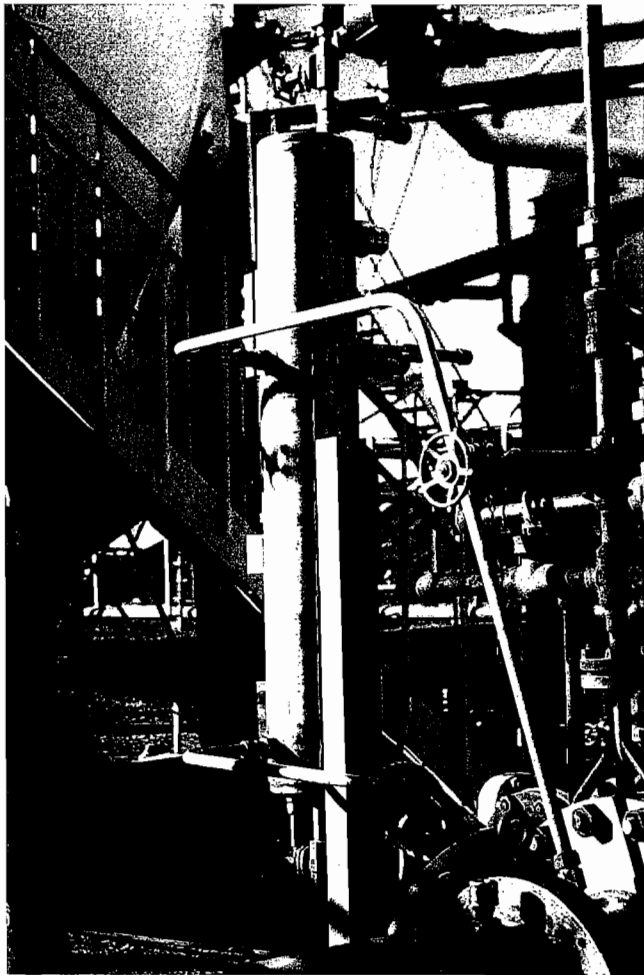

Figure 9. Seal Flange Tubing Connections.

Secondary Containment (VRS)

A number of pump seal systems used existing vapor recovery systems (VRS) for 100 percent containment when it was available

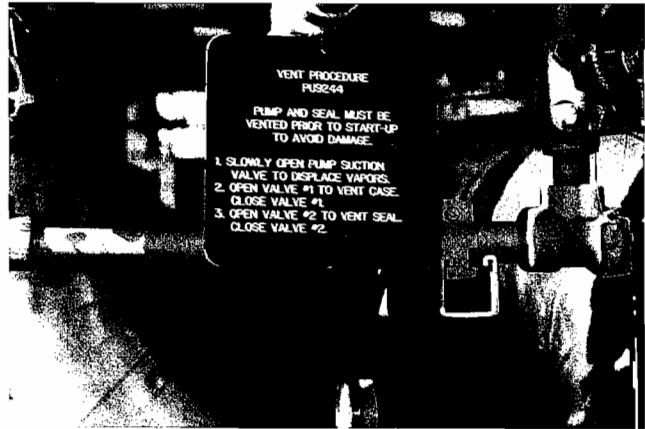

Figure 10. Seal and Pump Venting Procedure.

close to the pump installation. In many remote locations, total containment was required, but VRS was not available.

Alternative Technologies

Where total containment was required, and the only alternative was a nitrogen pressurized dual seal arrangement, an alternative arrangement was used. This involved new emissions control technology. This technology utilized compressed air passing through a jet ejector to pull emissions from pump seals or barrier fluid reservoir vents through a flameless reactor that thermally oxidized the VOCs to water vapor and carbon dioxide, as shown in Figure 11. Four units have been installed with good success; the system is 99.99 percent effective in reduction of VOCs.

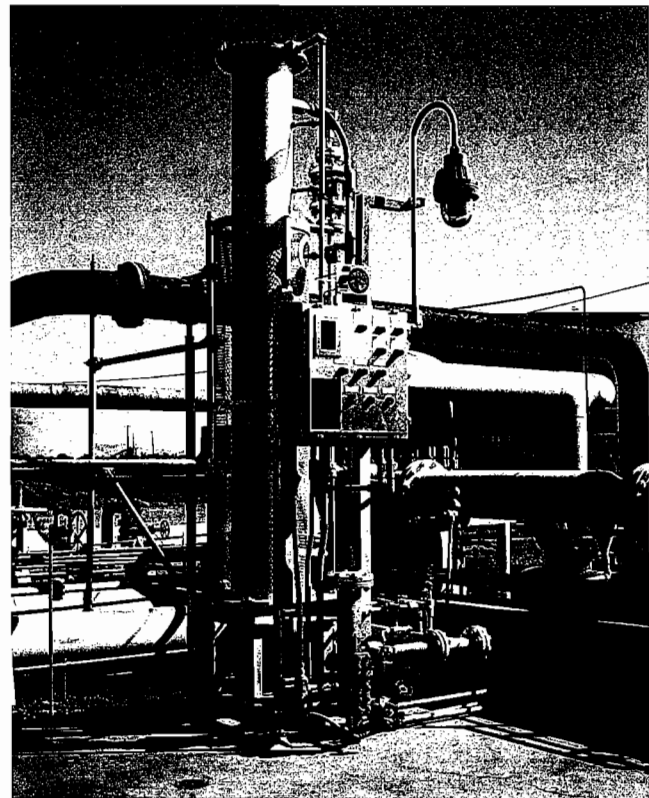

Figure 11. Thermal Oxidizer System.

Each unit currently controls emissions from 10 pumps. Future expansion up to 20 pumps is possible. These systems are expected to avert as many as 15 emissions repairs per year. Many of the noncompliant pumps are scheduled to be connected to a thermal oxidizer within the next year, possibly eliminating the need for further modifications.

VERIFICATION OF SYSTEM HYDRAULICS

Seal performance is affected by numerous internal and external forces. How a pump is sized for an application and how the pump is actually operated has a significant impact on seal life. In fact, it is a primary cause of poor seal life in a pumping system. Mechanical forces like misalignment, unbalance, flatness, concentricity, and perpendicularity are fairly well understood and relatively easy to control. Hydraulic forces, on the other hand, are generally not as well understood or recognized by the people charged with daily pump operation and maintenance. Furthermore, it is usually more difficult to remedy a hydraulic problem, since they are often related to the original design of the system.

Shaft deflection and vibration caused by unbalanced hydraulic forces can be very destructive to a pump, and severely shorten seal life. Before embarking on a project to improve seal performance, it is imperative that the pump's hydraulic performance be verified. The closer a pump operates to its best efficiency point (BEP), the longer the seal will last. This has been demonstrated many times in the field and was recently proven analytically in a computer model specifically designed to predict seal life based on its proximity to BEP.

DEVELOPING ALLIANCE PARTNERSHIPS

In order to develop a lasting alliance relationship, the arrangement must be profitable or beneficial for all parties. Both partners need to take mutual responsibility to ensure the desired goals. One of the first steps the newly formed alliances took was to develop well defined goals along with a mission statement:

Alliance Team Mission Statement

Adopt a fundamental philosophy of decreased mechanical seal life cycle costs through increased equipment reliability.

- Continuous reduction of pump and seal life cycle costs.
- Maximize equipment availability.
- Manage and document change accurately and completely.
- Improve data quality (new and existing).
- Get accurate process information from the owner/user.
- Provide root cause failure analysis.
- Honest communication of failure by owner.
- Buy-in by management and staff—down to the last person.

The alliance teams also developed metrics to assess the benefit of the arrangement and continue to improve it.

Metrics

DOLLARS

- 1) Cost of new seal purchases
- 2) Cost of seal repairs
- 3) Inventory reduction
- 4) Market share

RELIABILITY

- 1) Number of repairs
- 2) Mean time between failures

CONTRACTOR PERFORMANCE

- 1) Plant wide pump survey status
- 2) On-time delivery
- 3) Failure analysis submittal

COMPANY PERFORMANCE

- 1) Appropriate paperwork
- 2) On-time payment
- 3) Provides pump access

Involving Alliance Partners in all Facets of Project Activity

Candidate Pump/Seal Evaluation

Both the pump and seal alliance partners participated in all facets of the pump/seal evaluation.

• When a pump was added to the list, based on emissions survey, the pump vendor and company representatives interviewed operations personnel for possible insights on performance deficiencies and operational problems. This information along with service information was then assembled into a file.

• Process data, head and flow requirements, and physical data were then collected on the fluid being pumped, i.e., vapor pressure, solids concentration, etc.

This information was then summarized on the Pump Evaluation Summary form (Figure 12) and used to evaluate the best fix based on pump type, emissions, maintenance history, and performance data.

PUMP EVALUATION SUMMARY

PUMP TYPE _____ UNIT _____ NO. _____
 SISTER PUMPS _____ TRI NO. PU _____
 MODEL _____ DATE EVALUATED / /

HYDRAULIC PERFORMANCE			ADEQUATE?
ORIGINAL	EXISTING	%BEP	
HEAD			<input type="radio"/> YES
FLOW			<input type="radio"/> NO
NP/HA/R	/	/	
VAP. PRES.			
TEMP.			
S.G.			

OF NOTICES _____
 LAST NOTICE _____
 PPM _____
 DATE _____
 MAINTENANCE COST OVER LAST 7 YEARS _____
 # OF SEAL FAILURES PERIOD _____ MTBF _____
 IS THE SEAL CURRENTLY MEETING THE 1000 PPM LIMIT? YES NO

PRELIMINARY SEAL SELECTION
 SINGLE TANDEM

POSSIBLE REVAMP? YES NO

AFTER 1980 DESIGN? YES NO
 DESIGNED FOR SEALS? YES NO
 SHAFT DEFLECTION AT SEAL < 0.002 INCHES? YES NO
 STUFFING BOX VENT? YES NO
 SUFFICIENT STUFFING BOX AREA FOR TANDEM CARTRIDGE? YES NO
 BEARING HOUSING ACCEPTABLE? YES NO
 STEEL BEARING HOUSING? YES NO

RESCHEDULE

REVAMP
 RETROFIT BACK PULLOUT
 OTHER

NEW PUMP

SEAL UPGRADE
 SEAL SYSTEM \$ _____
 FIELD MODIFICATIONS \$ _____
 PIPING \$ _____
 INSTRUMENTATION \$ _____
 REMOVE/INSTALL \$ _____
 PUMP MODIFICATION (INCL CPLD) \$ _____
 TOTAL \$ _____

SEAL SYSTEM \$ _____
 FIELD MODIFICATIONS \$ _____
 PIPING \$ _____
 INSTRUMENTATION \$ _____
 REMOVE/INSTALL \$ _____
 PUMP MODIFICATION (INCL CPLD) \$ _____
 TOTAL \$ _____

SEAL SYSTEM \$ _____
 FIELD MODIFICATIONS \$ _____
 PIPING \$ _____
 INSTRUMENTATION \$ _____
 REMOVE/INSTALL \$ _____
 NEW PUMP ENCL (BASE, CPLD, ROUARD) \$ _____
 MOTOR \$ _____
 TOTAL \$ _____

REMARKS _____

FORM 92-PLR.DOC 7/19/95 11:26 AM

Figure 12. Pump Evaluation Summary.

Selection—The pump and seals alliance consultants then submitted proposals for the agreed upon upgrades. Attached to the

seal proposal was a seal proposal addendum (Figure 13) which gave design details for construction.

3/16/93

SEAL PROPOSAL ADDENDUM

PUMP#/UNIT: PU.... /

PUMP REPAIR TYPE:

SEAL:

PRODUCT:

TEMPERATURE: F

SUCTION PRESSURE: PSIG

VAPOR PRESSURE: PSIA

DISCHARGE PRESSURE: PSIG

SPECIFIC GRAVITY:

API PIPING PLAN:

SUCTION RETURN?:

QUENCH?:

PROPOSAL#:

TOSCO CATALOG #:

PUMP TYPE:

NUMBER OF BOXES:

COMMENTS:

SIGN-OFF: _____

Figure 13. Seal Proposal Addendum.

The seals alliance consultant also prepared a new seal order checklist (Figure 14) to further define the construction details. When field measurements were required, the pump was taken out of service and measured to ensure all the components fit precisely.

Installation and Startup—After the installation was completed, a QA/QC evaluation was made, the pump commissioning check list (Figure 15) was signed by the project representative and the operator prior to startup. The seal vendor usually witnessed the startup and recorded initial emissions levels.

Living Program Maintenance—As part of the long range compliance strategy, data are still being collected on all VOC equipment to evaluate future direction. Some areas where the alliances are now concentrating their efforts are:

- Provide ongoing training for maintenance and operations personnel. This training includes detailed information regarding the installation and operation of mechanical seals. It is expected that this training will greatly increase the MTBR and life cycle costs of pumping systems throughout the refinery.
- Continued development of records on seal life, seal failure analysis, life cycle costs, with focus on solutions to bad actor pump/seal systems.

NEW SEAL ORDER CHECKLIST - FOR OVERHAUL PUMPS

PUMP NUMBER: _____

FIELD MEASUREMENTS

- 1) Physically verify : []
- Shaft diameter _____ Bolt circle _____
- Stud size _____ First Obstr _____
- Gage Ring dist _____ Bolt Orientn _____
- 2) Suct Press _____ Disch Press _____ []
- 3) Rotation from driver end - CW / CCW []
- 4) Temperature _____
- 5) Make a diagram of the bearing web and the existing seal piping. Where can new seal piping be located? []
- 6) Note cage ring tap location(s). Can the seal box be vented through the cage ring taps? []
- 7) Is the existing seal the same model as indicated by the files ? []
- 8) What is the O.D. of the current seal gland. []

EVALUATIONS

- 1) Verify the vapor pressure if possible. Make sure that the box pressure is sufficient to keep adequate vapor suppression. []
- 2) Design the seal flush piping system including orifice sizing and throat bushing clearance in order to get the required flow and vapor suppression. []
- 3) Make sure there is adequate room for an O-Ring groove and multi-port injection between the box bore and the inside the stud holes. (especially important if box is to be bored) []
- 4) Verify that the seal selected will fit. OK any box boring that will be required with Tosco and pump manufacturer. []

Figure 14. New Seal Order Checklist.

- Incorporation of all seal and pump parts and repair services under a single manufacturer for each.

CONCLUSIONS AND RECOMMENDATIONS

Accomplishments

- One hundred percent of the 102 pumps modified by the Project since 1991 met 1993 emission limits.
- Over 60 percent of these pumps had initial emissions levels of 1000 ppm or more and the MTBR initially averaged eight months; after retrofitting the MTBR has increased to 16 months on average.
- Created alliances that set the criteria for cost effective procurement of pumps, seals, and provided accessibility to the most current technology resources.
- Established both an engineering standard for further VOC pump upgrades, and a repair and installation standard for pump and seals.

A key contributor to this success was the ability to view the solution as an overall system of modifications. Preexisting conditions such as pipe strain, unstable foundations, and misalignment were corrected to eliminate vibration, stresses, and distortions. As an added benefit, the reliability and safety of the equipment improved, thus lowering equipment life cycle costs.

Correlation of Bad Actors to Emissions Compliance

From 1990 to 1992, there had been numerous in-kind maintenance repairs made to equipment in response to emissions

**FUGITIVE HYDROCARBON EMISSIONS PROJECT
PUMP COMMISSIONING CHECK LIST**

PUMP NO.: _____ DATE: _____

MACHINISTS: Name: _____

1. COUPLING GUARD SECURE	_____	
2. HOLD DOWN BOLTS INSTALLED	PUMP _____	
	MOTOR _____	
3. FLANGES PROPERLY MADE-UP	_____	
4. JACKING BOLTS BACKED OFF	_____	
5. SEAL DRIVE COLLAR BOLTS TIGHTENED	_____	TORQUE: _____
6. SEAL SETTING PLATES ROTATED AWAY FROM COLLAR	_____	

COMMISSIONING ENGINEER: Name: _____

1. PROPER OIL LEVEL	PUMP _____	
	MOTOR _____	
2. PRESSURE GAUGES INSTALLED/ORIENTED	_____	
3. PIPE PLUGS INSTALLED	_____	
4. GASKETS INSTALLED	_____	
5. SMALL BORE PIPING SUPPORTED	_____	
6. NORMALLY-CLOSED VALVES CLOSED	_____	
7. ORIFICE PLATE INSTALLED WITH INSCRIBED TAB	_____	
8. COOLING WATER FLOWING	_____	
9. VENTING PROCEDURE SIGN POSTED AND VALVES TAGGED	_____	
10. AREA CLEANED UP	_____	
11. LOCKS/TAGS REMOVED	_____	
12. VENT PROCEDURE DELIVERED	_____	
13. SCREWED PIPING LEAK TESTED	_____	

**IF THERE ARE ANY PROBLEMS WITH THIS PUMP AFTER COMMISSIONING
CALL AT EXT. 3263**

Figure 15. Pump Commissioning Check List.

violations. Most of these repairs lasted only three to six months before another violation notice was received. The upgrades undertaken have, in many cases, doubled or tripled the time between emissions failures and eliminated chronic reliability problems.

Lessons Learned

There are three primary causes for premature seal failures and/or excessive vapor emissions from upgraded pumps:

- Installation errors
- Changes in the chemical composition of the pumpage
- Operational and hydraulic problems (such as dry running and cavitation)

The first item is the most controllable; the others are more challenging and require continuous education and training.

In addition to initial equipment installation, improved focus on equipment reliability through troubleshooting to resolve premature failures is needed. This is expected to take the form of additional training for both maintenance and operating personnel, revision of operating procedures, and continuous measurement of MTBF and life cycle costs.

A skilled team of dedicated experts can rebuild a pump perfectly and still fail to achieve the final objective if the pump/seal system is not started and operated properly. There are a number of details that must be attended to for success:

- Include process operators in the installation process. Have the production department assign responsible operators to the startup team. Communicate their responsibilities for a proper startup and continued operation, then conduct training on any special

requirements of the seal system. Use seal and pump partners to develop materials and deliver training.

- Develop prestart-up checklists, include the following procedures:
 - Steaming, flushing, and purging the pump casing prior to introducing product (minimize the time spent doing this to avoid contamination and overheating in the seal chamber).
 - Preparation for hot alignment checks (PT > 300°F and steam turbine driven pumps).
 - Review of existing pump startup instructions.
 - Prior to starting the pump, gather responsible core team members together, including alliance partners. Review the startup procedure and the duties of each team member. Develop a startup checklist including the following information:
 - Pump startup procedures, including venting all air and vapors from the seal chamber prior to, and during, startup.
 - Expected normal, minimum and maximum operating parameters (flow, temperature, pressure, viscosities, cooling, etc.).
 - Performance parameters, including suction and discharge pressures, flow temperatures, suction strainer differential pressure, and so on.
 - Program for continuous monitoring after startup.
 - Troubleshooting guidelines for operators and mechanics.
 - Pump and seal alliance partners should be full participants with users in the successful commissioning and operation of retrofit pumps. As stated earlier, they conditionally guarantee their equipment, *if all repair, installation, and startup conditions are met*. For this project, the seal alliance partner guaranteed fugitive emissions levels would not exceed BAAQMD limits for three years of continuous operation.
 - The ability to exercise a warranty is dependent on good documentation. Post startup documentation requirements must be agreed to with alliance partners as part of the initial parameters of the arrangement. As a minimum, the following data should be collected:
 - Fugitive emissions levels—Initially, the project team collected these data monthly, until levels stabilized, at which time the monitoring was turned over to the contractor responsible for collecting quarterly compliance data.
 - Vibration data—These data are also taken more frequently in the beginning, to catch infant mortality-type failures. When readings stabilize, then routine (documented) monitoring can resume.
- The importance of documentation can not be overstated. Proper documentation (API Standard 682, Shaft Sealing Systems for Centrifugal and Rotary Pumps, First Edition, October 1994) is required throughout the entire process from start to finish. The minimum requirements are listed below:
- Seals*
1. Completed API Standard 682 data sheets.
 2. Cross sectional drawing of all seals (modified typical).
 3. Schematic of any auxiliary system (or systems) including utility requirements.
 4. Electrical and instrumentation schematics and arrangement/connections.
 5. Seal manufacturer qualification test results, if specified.
 6. Detailed cross sectional drawings of all seals (specific, not typical).
 7. Detailed drawing of barrier/buffer fluid reservoir (if included).
 8. Detailed bill of materials on all seals and auxiliaries.

9. Material safety data sheets on all paints, preservatives, chemicals, and special barrier/buffer fluids.
10. Installation, operation, and maintenance manuals.
11. Pre and post startup checklists.
12. Routine performance monitoring data sheets.

Pumps

1. *Completed* API Standard 610 data sheets.
2. As found and as built specifications (rebuilt pumps).
3. Pump manufacturer performance test results, if specified.
4. Detailed cross sectional drawings of all pumps (specific, not typical).
5. Detailed bill of materials on all pumps and auxiliaries.
6. Material safety data sheets on all paints, preservatives, and chemicals.
7. Installation, operation, and maintenance manuals.
8. Installation checklists.
9. Pre and post startup checklists.
10. Routine performance monitoring data sheets.

ONGOING PROGRAM PERFORMANCE

In closing, the importance of continuing to work within the alliance partnerships cannot be overemphasized. They require

constant nurturing and attention. Resistance to using the alliance will be an ongoing issue for the team members. The alliance must constantly review the performance of the partnership itself and compliance with stated goals and objectives. A formal and periodic review process should be formulated.

Additionally, long term issues such as how to provide continuous improvement (CI) to the alliance relationship are important. There are many facets to CI, but typically involves empowering employees to actively pursue improvements; providing technical support at the front line, rigorous root cause failure analysis, and use of advanced analytical techniques. Along with CI is the need to maintain a living program; a living program is basically the practice of maintaining the new way of doing business. Buying quality spare parts, quality control, standardization, meticulous pump and seal overhauls, consistent, detailed documentation, and a highly skilled and motivated work force.

ACKNOWLEDGEMENT

The authors would like to thank Gil Tigno of the Tosco Refining Company for his contributions to the success of this program.