

Principles of Screening and Sizing

Presented By: George Schlemmer



LIGHTEN UP!

Today's Agenda

- Provide you with information to promote a safer, more cost efficient operation.
- Topics covered to include:
 - Performance and carrying capacity.
 - Review external factors (type of material, amount of near size in the material, shape of material).
 - Review the screen sizing formula and the effects that each of the above can have on the sizing process.
 - Review speed, stroke and slope.
 - Media options available to today's producers and there applications.
 - Troubleshooting guidelines and items to review at the quarry.

Screen Duties

- To prepare a sized product.

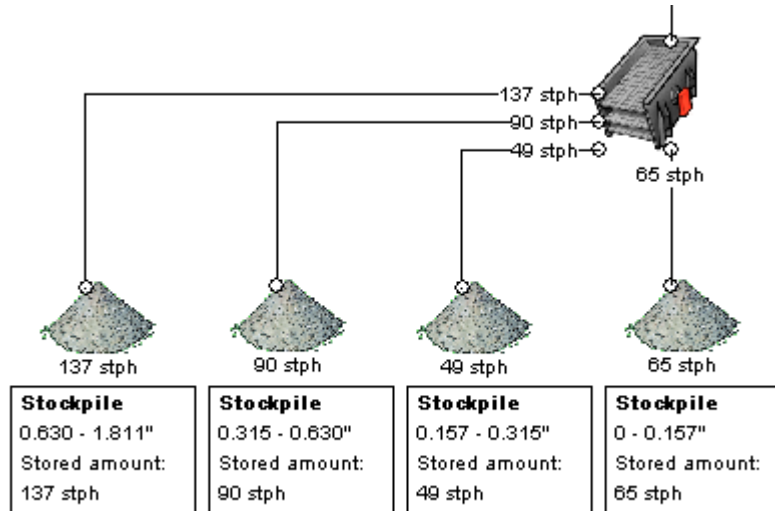

- Take home message: Final product sizing.

Screen Duties



Screen Performance

- Stratify the material.
- Prevent pegging.
- Prevent blinding.
- Separate the material into two or more fractions.
- Transport the material to provide the screen its carrying capacity!

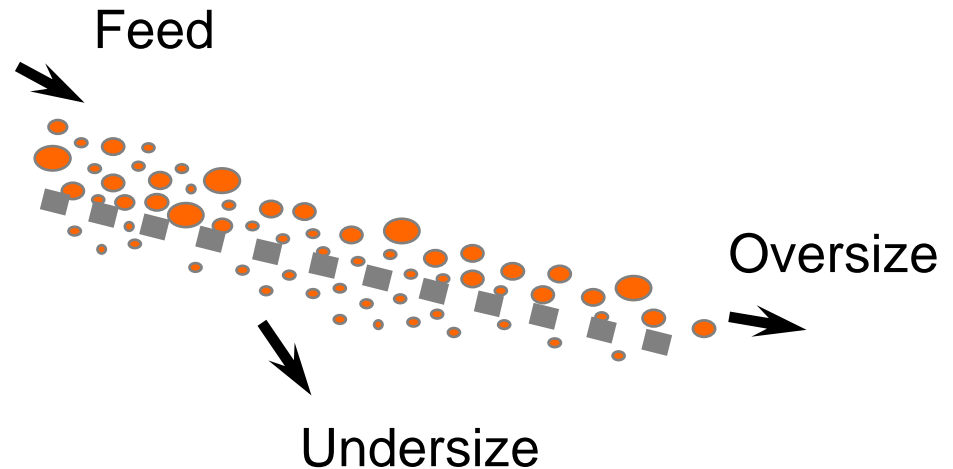

Carrying Capacity...the amount of material a screening machine can carry over the decks before the momentum of the screen body is overcome by the weight of the material.

Carrying Capacity

- Carrying Capacity - amount of material a vibratory screen can carry over the decks before the momentum of the screen body is overcome by the weight of the material.
- Factors for carrying capacity calculations include:

$$\text{CARRYING CAPACITY} = \frac{m \times v \times s^2 \times n^2}{C \times l}$$

- m = moving mass in screen body
- v = speed of material over the deck
- s = stroke length
- n = rotational speed (RPM)
- l = length of screen
- C = constant derived from performance data

Information Required to Measure Screen Performance and Solve Problems

- Application factors
 - Material characteristics (Wet, dry, slivers, openings)
- Screen set-up
 - Speed, stroke, slope, direction of rotation, etc.
- Feed rate (stph) and material bed depth
- Media
 - Media type, open area, wire diameter, opening shape
- Maintenance & Installation
 - Natural frequency vs. operating frequency
 - Tension on v-belts
 - Correct installation of motor base(s)
 - Springs
 - Proper torque for all fastening hardware
 - Level

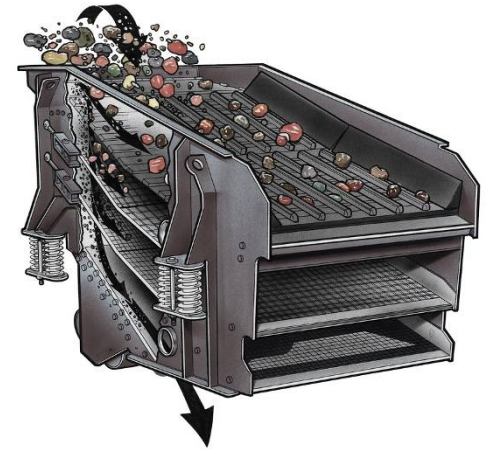

Factors Which can Effect Screening

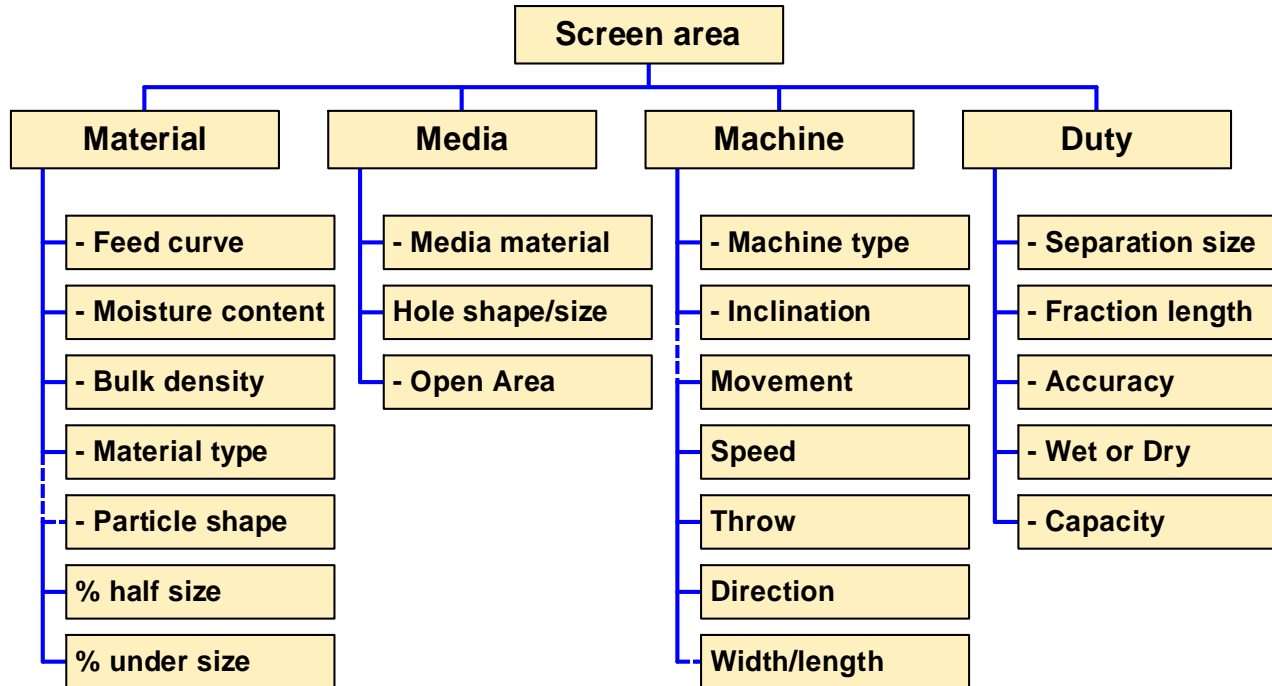

How Application Factors Affect Capacity and Accuracy

Application / modifying factors:

- Half size in feed – Higher % of half size increases capacity
 - Oversize in feed – Lower % of oversize increases capacity
 - Wet screening – Increases capacity
 - Slotted openings – Increases capacity
 - Finer wire diameter < open area – Increases capacity & efficiency
 - Reduce efficiency rate – Increase capacity
 - Moisture – Reduces capacity & efficiency
 - Elongated particle shape – Reduces capacity & efficiency
 - Near size material – Reduces capacity & efficiency
-

Determining Screen Capacity

- **Each opening has a volumetric throughput capacity:**
 - Basic capacity figure is expressed as **tph per sq.ft.**
 - Figure is multiplied by the sq. footage of the screen deck.
 - Calculation gives the basic capacity of each deck and the total capacity of the vibrating screen.
- **The vibrating screen capacity is determined:**
 - Using a standard sizing formula (9 variables).
 - Basic capacity of each deck opening.
 - Unique factors of that application.
 - Maximum bed depth allowed for the openings and particle size.

Screen Area Calculation

Basic formula for calculating screen area (per deck)

$$\text{Screening Area} = U / (A \times B \times C \times D \times E \times F \times G \times H \times J)$$

- U: Required screening area (Sq.ft.)
- A: Nominal capacity for separation
- B: % Oversize (.33 – 1.21)
- C: % Halfsize (.40 – 2.40)
- D: Deck location (.80 – 1.0)
- E: Wet screening (1.0 – 1.25)
- F: Material weight (.30 – 1.50) lbs/cu.ft
- G: Open area of media
- H: Shape of opening (1.00 – 1.20) sq-short-long
- L: Accuracy (.70 – 1.70)

Material: Granite
 Maximum feed amount: 1085 m³/h
 Actual feed amount: 1085 m³/h
 Work index: 19.7
 Bulk density: 1.6 ton/m³
 Abrasion index: 0.7

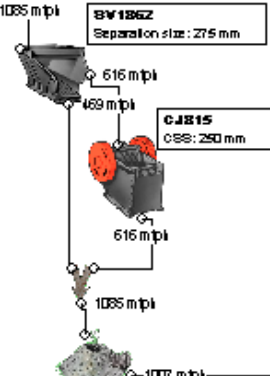

3V186Z
 Separation size: 275 mm

CJB15
 CSS: 250 mm

Plant Feed PSD

| (mm) | (%) |
|------|-------|
| 1000 | 100.0 |
| 500 | 81.0 |
| 250 | 39.0 |
| 200 | 28.0 |
| 150 | 18.0 |
| 100 | 9.4 |

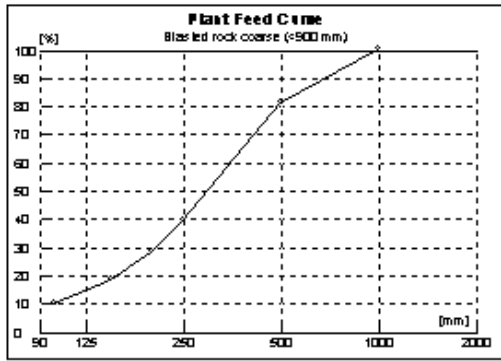

Feed In = Feed out
 Selected feeder: SP 1630H

0 m³/h, 0%



CB660 EC
 Throw: 30 mm
 CSS: 60 mm
 Machine Load: 75% (1007 m³/h)

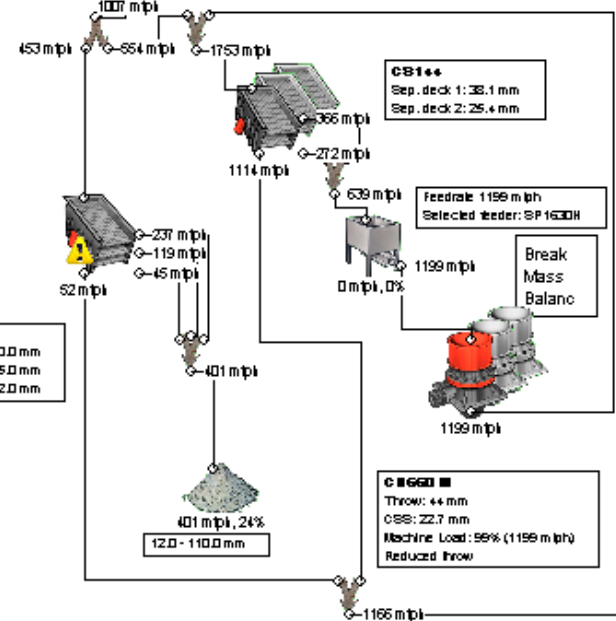

CB173
 Sep. deck 1: 18.0 mm
 Sep. deck 2: 12.5 mm
 Sep. deck 3: 9.0 mm
 Sep. deck 4: 4.8 mm

CB114
 Sep. deck 1: 38.1 mm
 Sep. deck 2: 25.4 mm

Feeder: 1199 m³/h
 Selected feeder: SP 1630H

Break Mass Balance

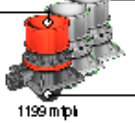

CB660 F
 Throw: 44 mm
 CSS: 22.7 mm
 Machine Load: 56% (1199 m³/h)
 Reduced throw

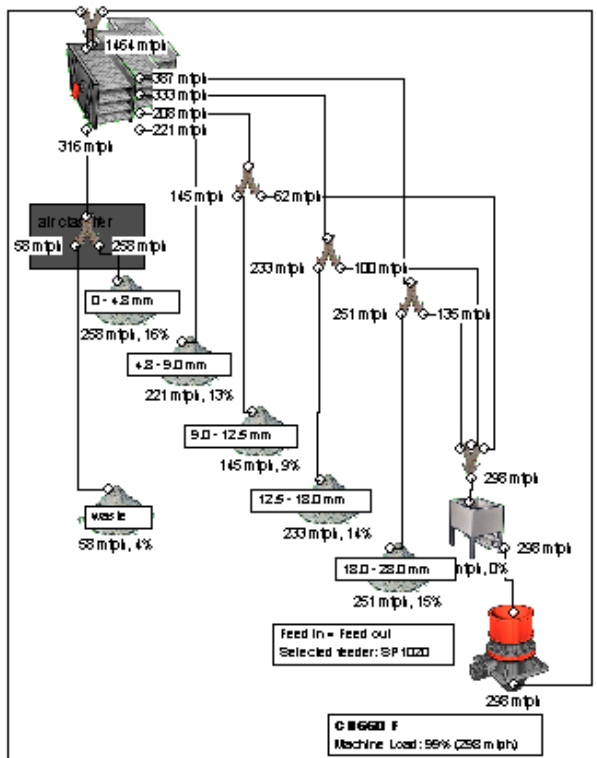

1454 m³/h
 337 m³/h
 333 m³/h
 238 m³/h
 221 m³/h

316 m³/h
 58 m³/h, 4%

258 m³/h, 16%

258 m³/h, 16%

4.8 - 9.0 mm

221 m³/h, 13%

9.0 - 12.5 mm

145 m³/h, 9%

12.5 - 18.0 mm

233 m³/h, 14%

18.0 - 25.0 mm

251 m³/h, 15%

251 m³/h, 15%

258 m³/h, 16%

258 m³/h, 16%

258 m³/h, 16%

258 m³/h, 16%

258 m³/h, 16%

258 m³/h, 16%

258 m³/h, 16%

258 m³/h, 16%

258 m³/h, 16%

258 m³/h, 16%

258 m³/h, 16%

258 m³/h, 16%

258 m³/h, 16%

258 m³/h, 16%



PlantDesigner Preliminary
 Flow Sheet Calculations

| | |
|------------------|----------------------|
| Date: 2009-09-30 | Customer: |
| Drawn by: | Project: Preliminary |
| Approved by: | |
| Project no: | File name: |

Remarks:
 FlowSheet simulation calculated with:
 - Metric units, Square Laboratory sieves
 - Normal Screen Calculation Method

Uc. No. 3010-SEF11-56J 0-USAJ
 Last Calc. 2009-09-22 14:47

Please note that PlantDesigner(R) gives indicative values, based on typical operating conditions. Since operating conditions can vary widely, no warranty of these recommendations either expressed or implied is given by PlantDesigner(R), its owners or supplier.



CS173
 Sep. deck 1 (Wire, Sq): 0.709"
 Sep. deck 2 (Wire, Sq): 0.492"
 Sep. deck 3 (Wire, Sq): 0.354"
 Sep. deck 4 (Wire, Rect Tr): 0.187"

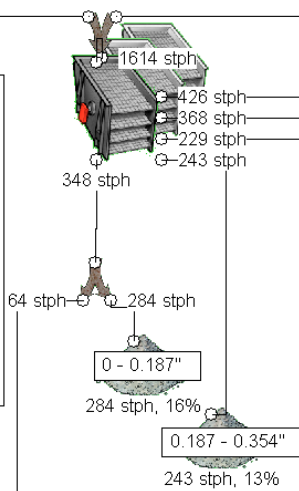
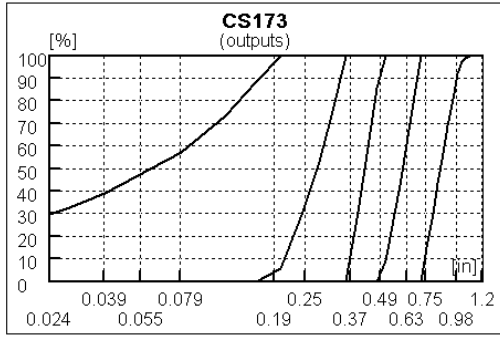

Selected Feeder: SP1630H
 Load: 79%, 1322 stph

Screen CS173
 3 units in parallel setup

Deck 1
 Separation size: 0.71"
 Flow from deck: 426 stph
 Deck material: Wire, square holes
 Screen deck precision: 10/15 %
 Screen deck load: 83 %
 Bed depth at feed end: 88 %, 3.3", min: 1.5", max: 3.7"
 Bed depth at discharge end: 40 %, 0.9", min: 0.7", max: 2.1"

Deck 2
 Separation size: 0.49"
 Flow from deck: 368 stph
 Deck material: Wire, square holes
 Screen deck precision: 10/15 %
 Screen deck load: 92 %
 Bed depth at feed end: 70 %, 2.4", min: 1.1", max: 3.4"
 Bed depth at discharge end: 49 %, 0.7", min: 0.5", max: 1.5"

Deck 3
 Separation size: 0.35"
 Flow from deck: 229 stph
 Deck material: Wire, square holes
 Screen deck precision: 10/15 %
 Screen deck load: 94 %
 Bed depth at feed end: 56 %, 1.7", min: 0.9", max: 3.0"
 Bed depth at discharge end: 41 %, 0.5", min: 0.4", max: 1.1"

Deck 4
 Separation size: 0.19"
 Flow from deck: 243 stph
 Deck material: Wire, Rect. tr. holes

Print

Stockpile

| stph | Dis. 1 |
|-----------|--------|
| 243 | 0.4 |
| F100: 0.4 | |
| [in] [%] | |
| 0.37 | 100.0 |
| 0.19 | 4.6 |
| 0.093 | 0.0 |
| 0.046 | 0.0 |
| 0.024 | 0.0 |
| 0.012 | 0.0 |
| 0.0059 | 0.0 |
| 0.003 | 0.0 |

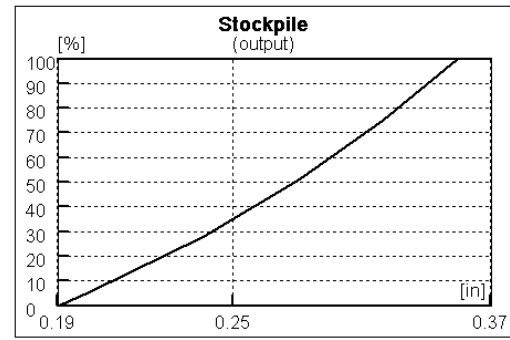

- U: Required screening area (Square feet)
- A: Nominal capacity for separation
- B: % Oversize (.33 – 1.21)
- C: % Halfsize (.40 – 2.40)
- D: Deck location (.80 – 1.0)
- E: Wet screening (1.0 – 1.25)
- F: Material weight (.30 – 1.50) lbs/cu.ft
- G: Open area of media
- H: Shape of opening (1.00 – 1.20) sq-short-long
- L: Accuracy (.70 – 1.70)

8x20 = 160 sq.ft. per deck



Common Factors which can Reduce Capacity and Accuracy

- Basic capacity figure is based on two key factors:
 - Feed with a maximum of 25% oversize
 - Minimum of 40% half-size
- Basic capacity is modified:
 - Increased or decreased based on the actual factors in each application.
- Material bed depth:
 - At discharge end; should not be deeper than 4x the deck opening.
 - Example: $\frac{1}{2}$ " opening x 4 = 2" material bed depth.
 - If bed depth exceeds this ratio, accuracy is reduced.

Screen Width

- Screen width controls material bed depth which allows material stratification and separation to take place.
- **Width = Capacity, Length = Accuracy**
- Material bed depth gauge:
 - Should not exceed 4x the deck opening at the discharge end.
 - Ideally you should be able to see the last few feet of media.

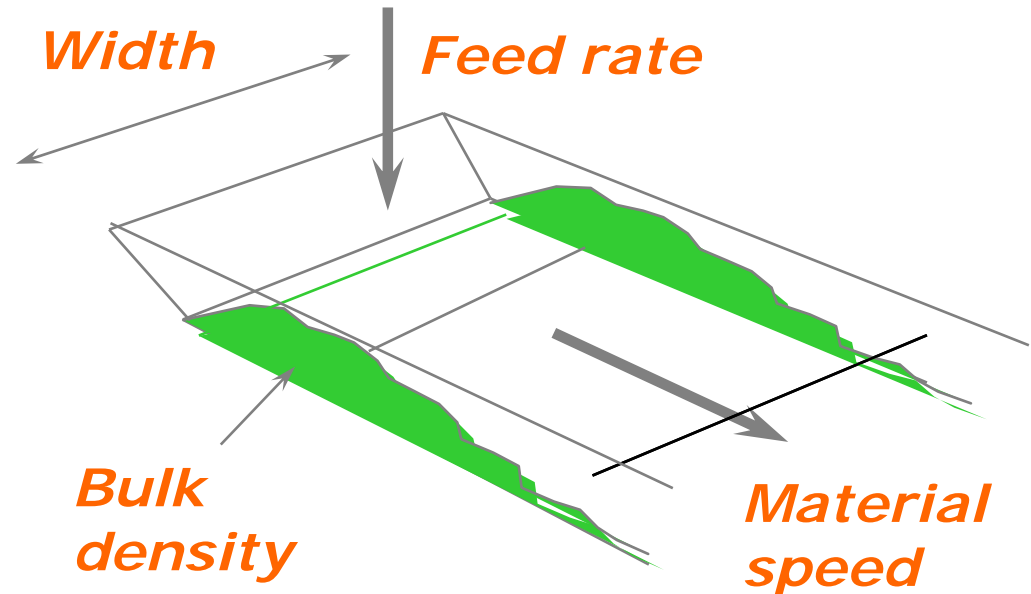

Screening Theory

Accuracy defined:

- The degree of correctness of a quantity, expression, etc.
- Expressed as the ratio of allowable percentage of maximum oversize and undersize in the final product. I.e. 10/10, 10/20, 15/20...

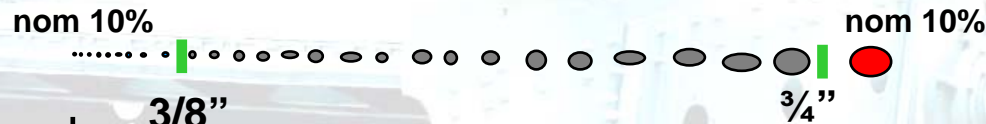

Efficiency defined:

- The percentage of work done.
- Normally expressed as; 80%, 85%, 90%, 95% objective screening efficiency, with no specific or defined reference to the allowable percentage of oversize or undersize in the product.

True Screening – Example A

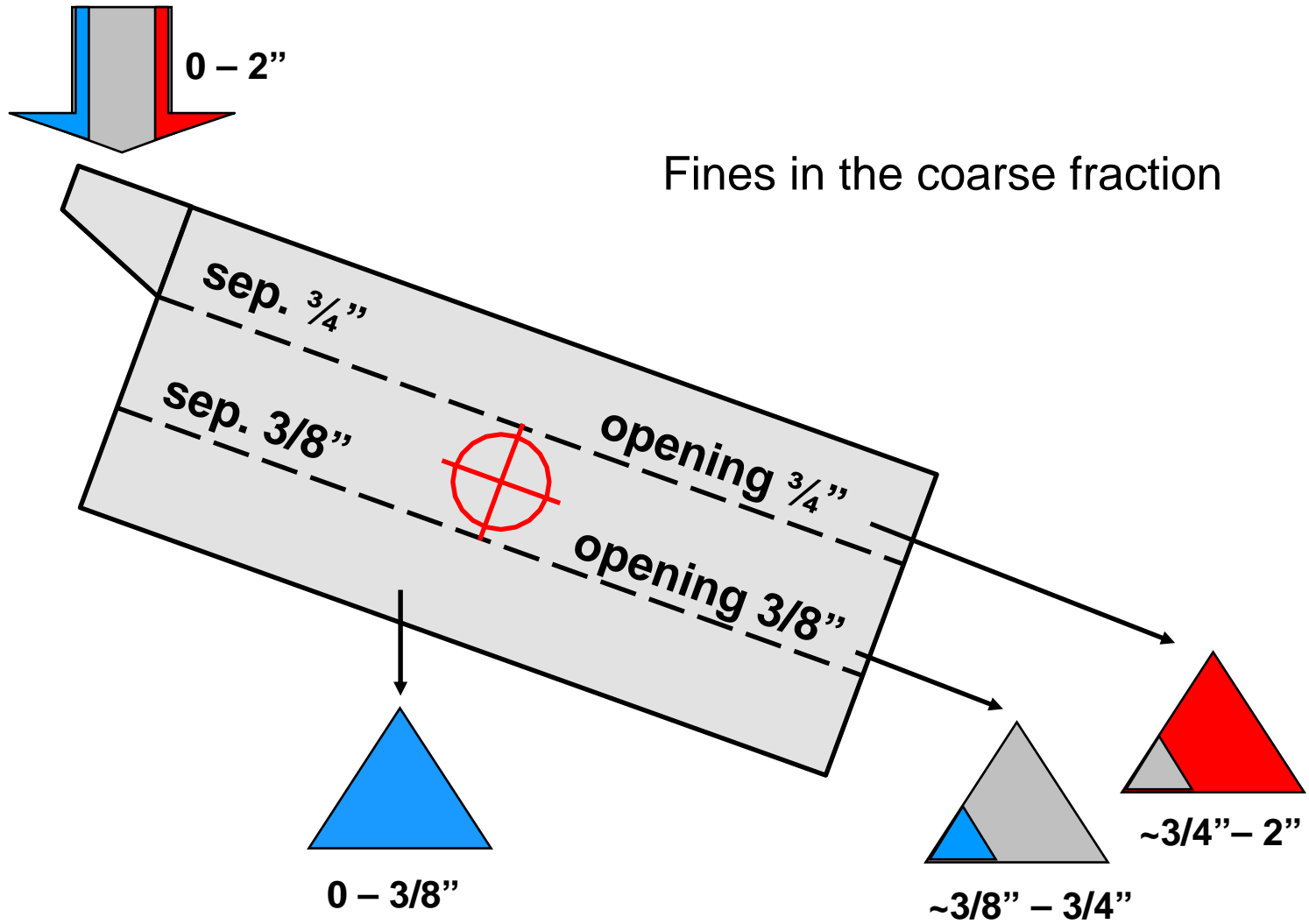

True Screening – Example B

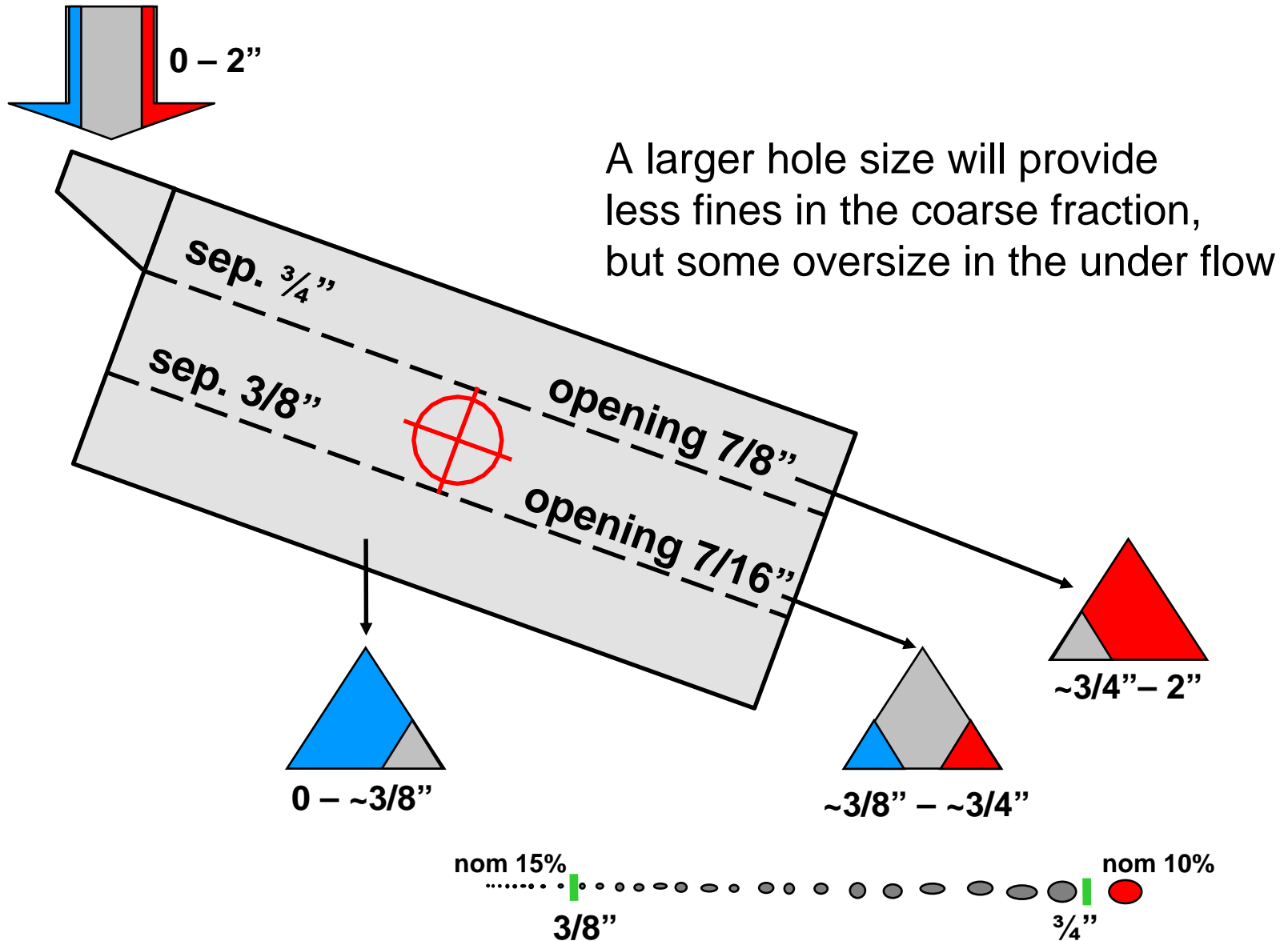

Screening Theory

Accuracy demand

| Max Over/Undersize | Factor: L |
|--------------------|-----------|
| 10/10 | 0.7 |
| 10/15 | 1.0 |
| 10/20 | 1.2 |
| 15/20 | 1.3 |
| 20/25 | 1.5 |
| 20/30 | 1.7 |

- Take home message: Accuracy of the fraction produced by the deck. A true representation of the real world limits in which screens operate and aggregate specifications are written.

Which bed depth is right for stratification?

- ***A thin bed:***



- Becomes easily fluid, helps stratification.
- Shorter distance for fine particles to sift down to the deck.
- Less pegging tendency, stones are not forced down.

- ***A thick bed:***



- Can reduce accuracy.
- Overload the screen – carrying capacity.

Which Bed Depth is Correct for Accuracy? (Discharge end)

- Maximum bed depth at discharge end is 4x the separation.
 - If too thick, probability is decreased for sized aggregate to properly stratify and pass through an opening.
- Minimum bed depth is 1x the separation.
 - If too thin, material can bounce, stay suspended and not stratify or find an opening, thus reducing accuracy.

Screen Operation

- After correct screen size is selected, optimal performance results from appropriate operation.
- Unit must be operated at the best combination of the below variables:
 - Speed
 - Stroke
 - Slope
 - Direction of rotation

Screen Speed and Stroke in Combination with Deck Openings

- Speed = RPM (800 RPM).
- Stroke = Diameter of circular motion (.375" Diameter).
- Material is stratified, separated and screened.

- Large openings = Large stroke and slower speed.
- Small openings = Small stroke and higher speed.

INCLINED SCREENS

Stroke, Speed and Slope Selection

| Stroke (in.) | Nominal Speed (RPM) | Top Deck Opening | | | | | | | | | | | | Slope Range (degree) |
|--------------|---------------------|------------------|---------|---------|--------|--------|--------|-------|--------|-------|-------|-------|----------|----------------------|
| | | 35M-50M | 20M-35M | 10M-20M | 4M-10M | ½"-4M | 1"-1½" | 2"-1" | 3"-2" | 4"-3" | 6"-4" | 8"-6" | Above 8" | |
| 03 | 3500 | Blue | | | | | | | | | | | | 24-30 |
| 05 | 2600 | Orange | | | | | | | | | | | | 24-30 |
| 06 | 2100 | Blue | | | | | | | | | | | | 22-28 |
| 3/32 | 1800 | | Orange | | | | | | | | | | | 22-26 |
| 1/8 | 1600 | | Blue | | | | | | | | | | | 22-26 |
| 3/16 | 1400 | | | Orange | | | | | | | | | | 20-25 |
| 1/4 | 1000 | | | Blue | | | | | | | | | | 18-25 |
| 5/16 | 900 | | | | | Orange | | | | | | | | 18-25 |
| 3/8 | 850 | | | | | Blue | | | | | | | 18-25 | |
| 7/16 | 750 | | | | | | | | Orange | | | | | 18-25 |
| 1/2 | 700 | | | | | | | | | | Blue | | | |



For dry 100 lbs/cu.ft. material and flow mechanism rotation.

Horizontal Screens and Feeders Stroke and Speed Selection

| Stroke (in.) | Nominal Speed (RPM) | Top Deck Opening | | | | | |
|-----------------|------------------------|------------------------|--------------|-------------|-------------|-------------|-------------|
| | | Less than 10M | 4M to 10M | ½" to 4M | 1" to ½" | 2" to 1" | 4" to 2" |
| 3/8 | 950 | Consult VSMA Member | Orange | | | | |
| 7/16 | 900 | | Blue | | | | |
| 1/2 | 850 | | | Orange | | | |
| 5/8 | 800 | | | Blue | | | |
| 3/4 | 750 | | | | Orange | | |

Vibrating Feeders

1/2" to 5/8" stroke is common, 700 – 800 RPM

For dry 100 lbs/cu.ft. material and flow mechanism rotation.

Vibrating Feeders – Approximate Capacity

| RPM | 30" (.76 m) Wide | | 36" (.91m) Wide | | 42" (1.07m) Wide | | 50" (1.27m) Wide | | 60" (1.5m) Wide | |
|------|---------------------|------|--------------------|------|---------------------|------|---------------------|------|--------------------|------|
| | TPH | mt/h | TPH | mt/h | TPH | mt/h | TPH | mt/h | TPH | mt/h |
| 600 | | | | | | | | | 828 | 754 |
| 650 | | | | | | | 623 | 568 | 898 | 818 |
| 700 | | | 315 | 287 | 473 | 431 | 671 | 611 | 967 | 881 |
| 750 | 270 | 246 | 337 | 307 | 507 | 462 | 720 | 656 | 1035 | 943 |
| 800 | 290 | 264 | 360 | 328 | 541 | 493 | 767 | 698 | | |
| 850 | 305 | 278 | 382 | 348 | 575 | 524 | | | | |
| 900 | 325 | 296 | 404 | 368 | 609 | 555 | | | | |
| 950 | 345 | 314 | 427 | 389 | 642 | 585 | | | | |
| 1000 | 365 | 332 | | | | | | | | |

| | | | | | | |
|----------------|-----|------|------|-----|-----|------|
| Angle Downhill | 0° | 2° | 4° | 6° | 8° | 10° |
| Multiplier | 1.0 | 1.15 | 1.35 | 1.6 | 1.9 | 2.25 |

Capacity multipliers for feeder pan mounting angles from 0° to 10°

Factors Affecting Material Speed

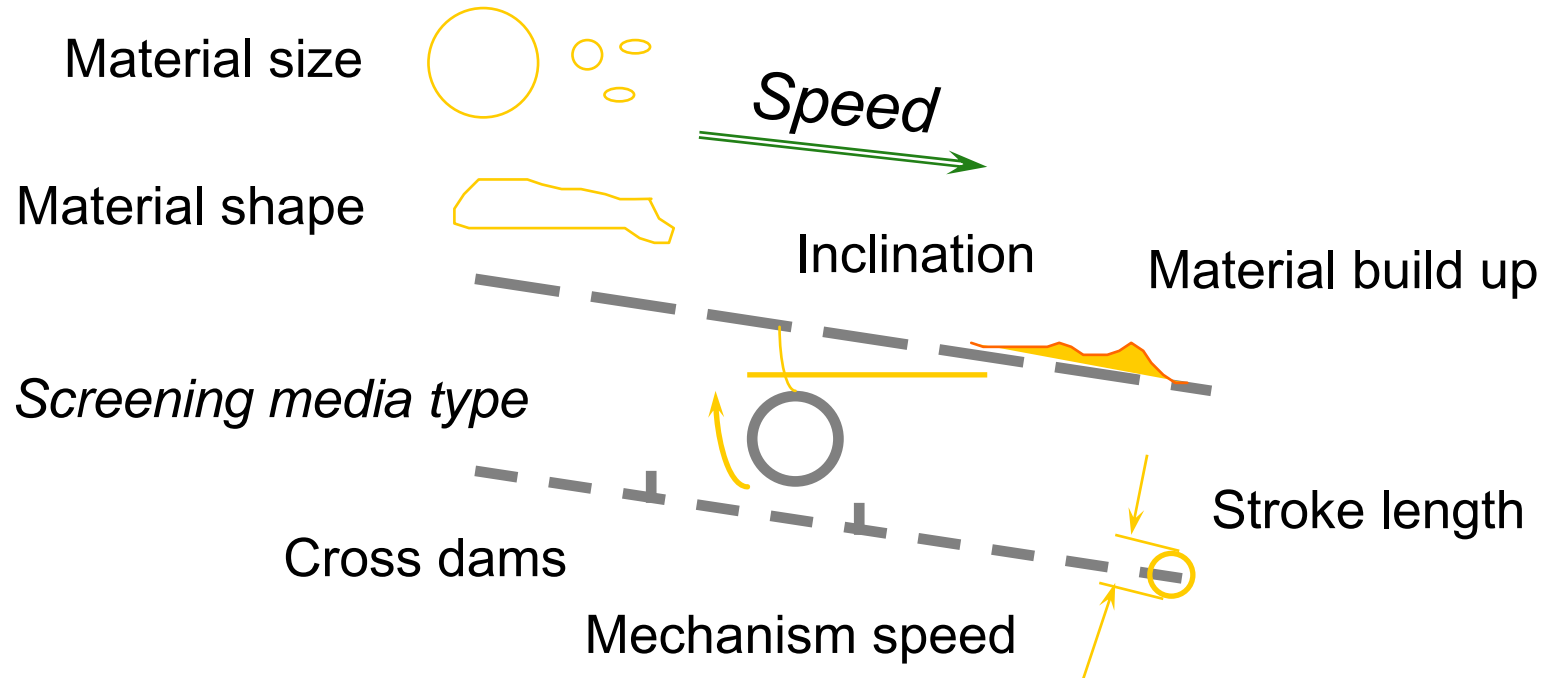

Gravity Free Fall = 32.2 ft/second

$$G_{\text{force}} = \frac{\text{RPM}^2 \times \text{Throw}}{70418}$$

$$G_{\text{force}} = \frac{800^2 \times 7/16''}{70418} = 3.9$$

Direction of Rotation

- With-flow rotation is always preferred.
 - (always consult manufacturer before reversing rotation)
- Counter-flow rotation can produce higher screening accuracy, but can also limit overall capacity due to slower travel speed and high bed depth.

Speed and Stroke Combination Summary

- **Speed & stroke** are interrelated and selected in standard combinations to offer optimum screening.
- **Speed** is selected to help create a **sufficient material travel rate** to produce a shallow enough bed depth that allows the fines to sift through the material bed and screen out.
- **Stroke** is selected to be **sufficient to prevent plugging** but not so great that it affects the life of the frame, mechanism, screen media, or interferes with the screening process.
- B10 Life = Minimum 10,000 hours.

Screening Media

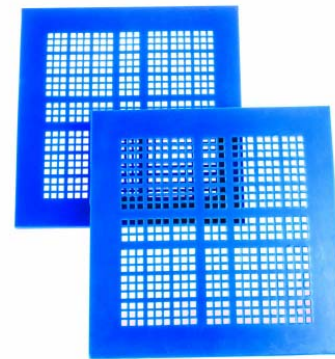
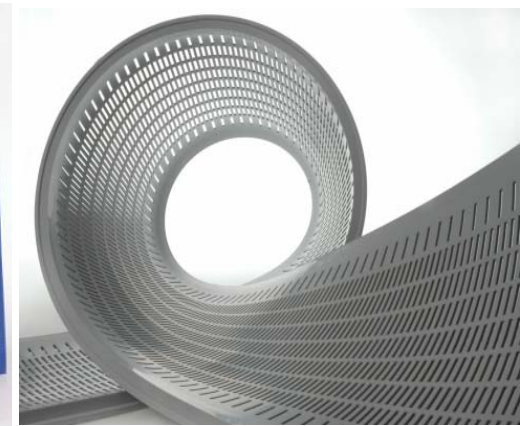

Screening Media

- Woven wire cloth
- Plastic (Monofilament)
- Piano wire
- Rod deck
- Grizzly bar
- Louvered deck
- Profile deck
- Polyurethane(PU)
- Rubber
- Perforated plate
- Cast plate deck
- Rubber clad perforated plate

Screening Media – Woven Wire

- Woven wire cloth - openings
 - Square (clear opening / mesh)
 - Long slot
 - Short slot
 - Z slot
 - S slot
 - L slot

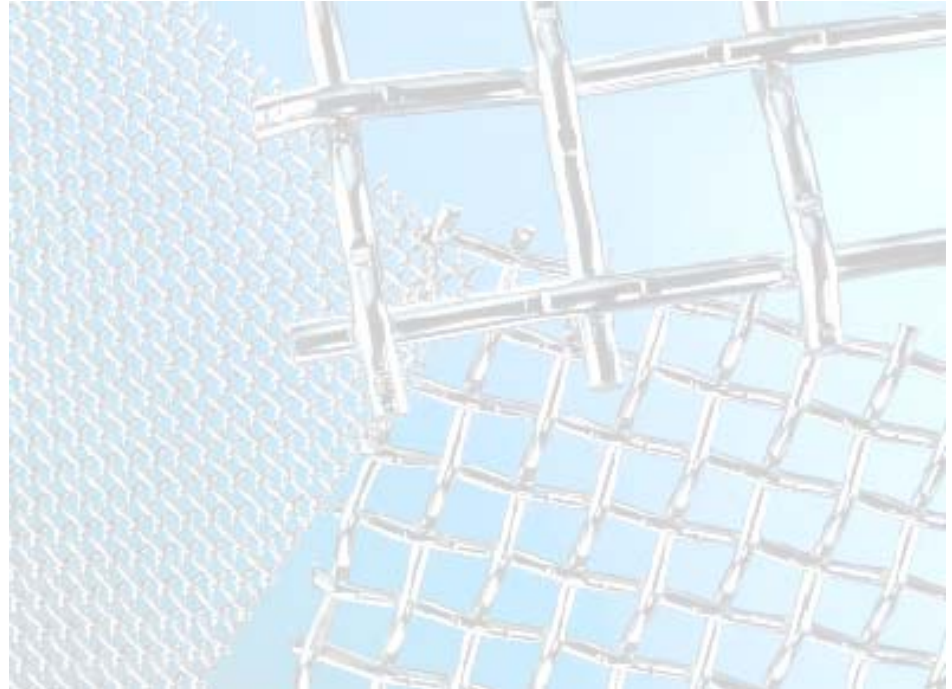

Screening Media – Woven Wire

- Woven wire cloth - weave
 - Plain weave
 - Semi-crimp
 - Double crimp
 - Press lock crimp
 - Intermediate crimp
 - Flat top weave
 - Press crimp

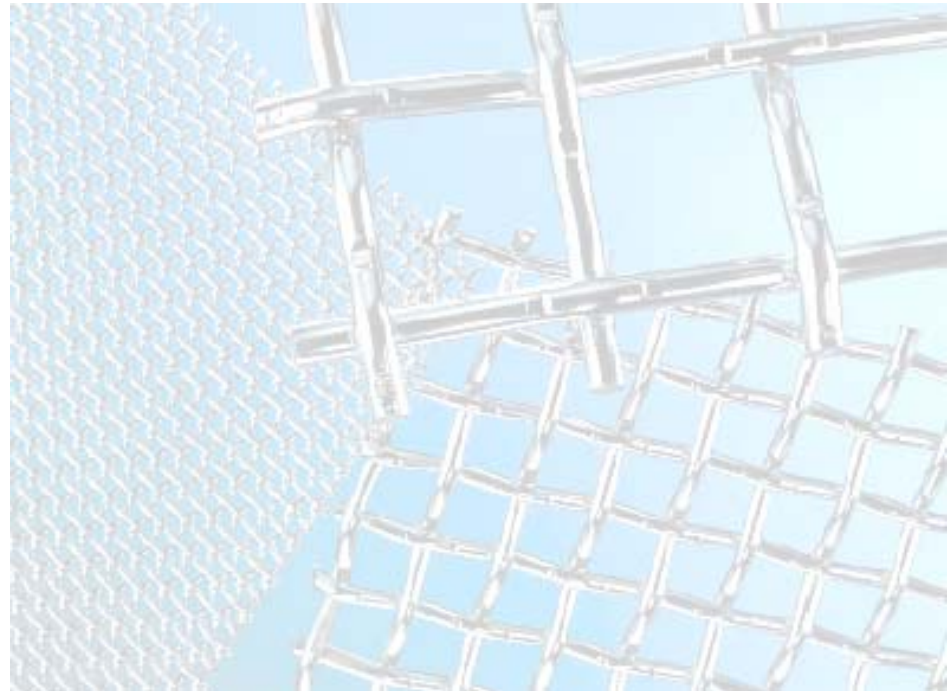

Screening Media – Woven Wire

- Material
 - Stainless steel alloys
 - Heat resistant alloys
 - Copper alloys
 - Aluminum
 - Nickel alloys
 - High carbon steel
 - Oil tempered

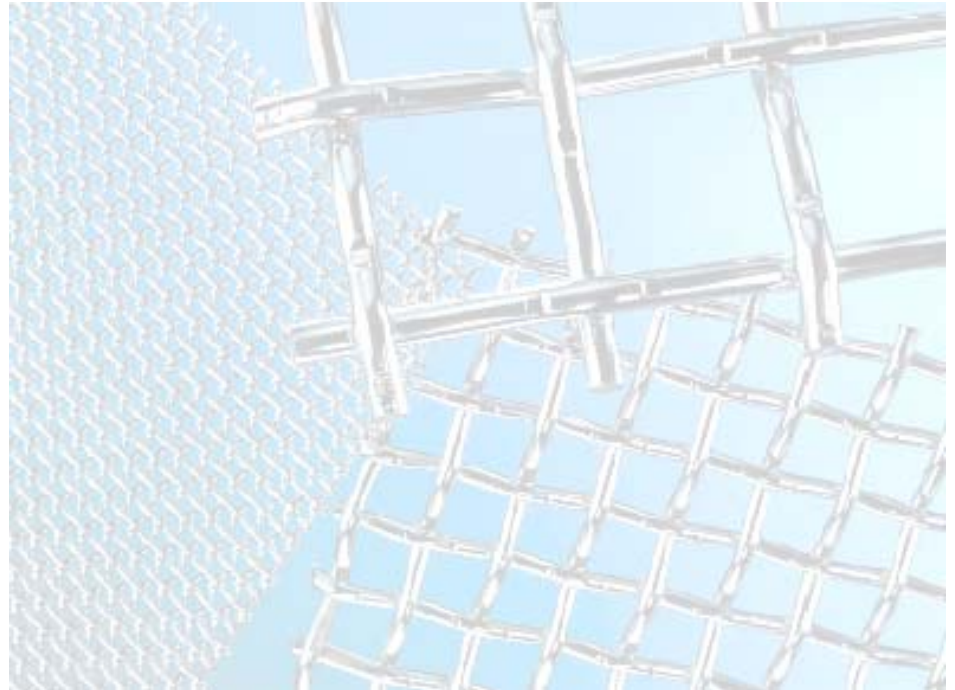

Screening Media – Woven Wire

- Hook strips
 - Hooked edge – 45°
 - Single reinforcing
 - Square
 - Welded insert
 - Welded square bar
 - U-hook strip

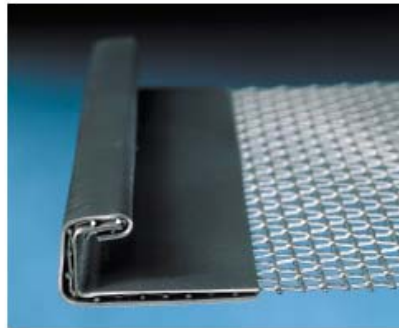
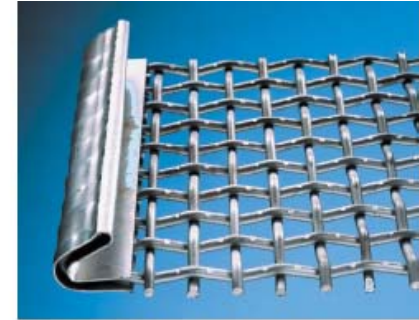

Screening Media – Woven Wire

- Hook strips
 - Double reinforced
 - Welded insert
 - Knuckled Edge
 - Welded edge wire
 - Folded hook strip
 - 90° Welded plate
 - Taped edge...

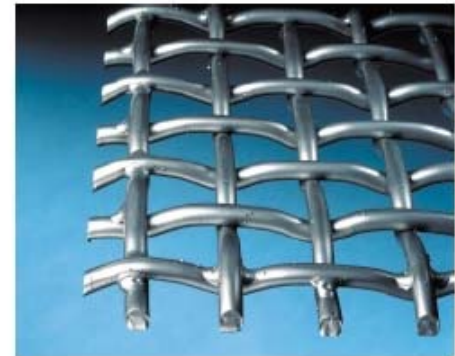

Media Installation

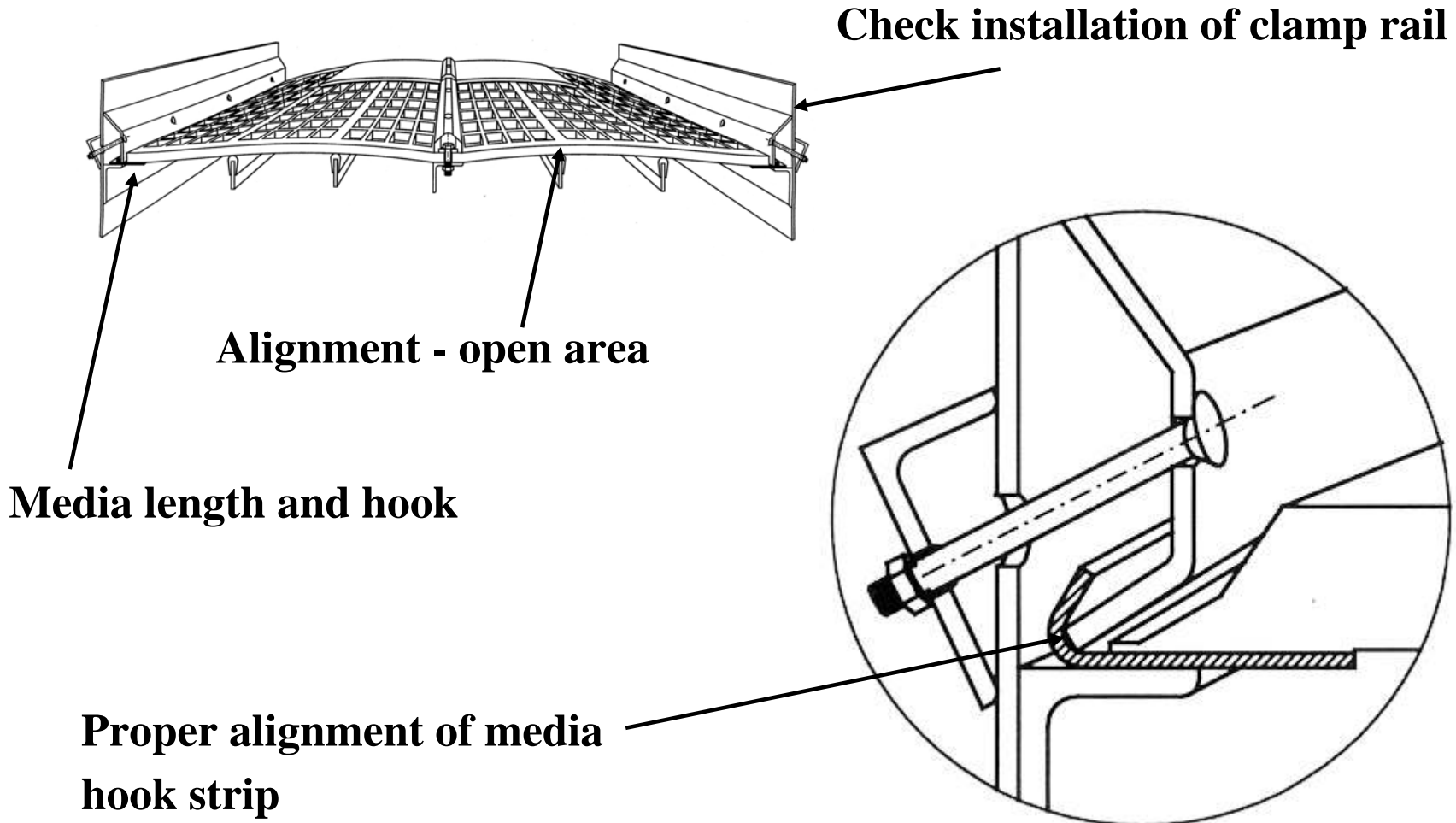

Screening Media – PU

A modular screening media for fine to medium coarse screening in wet applications.

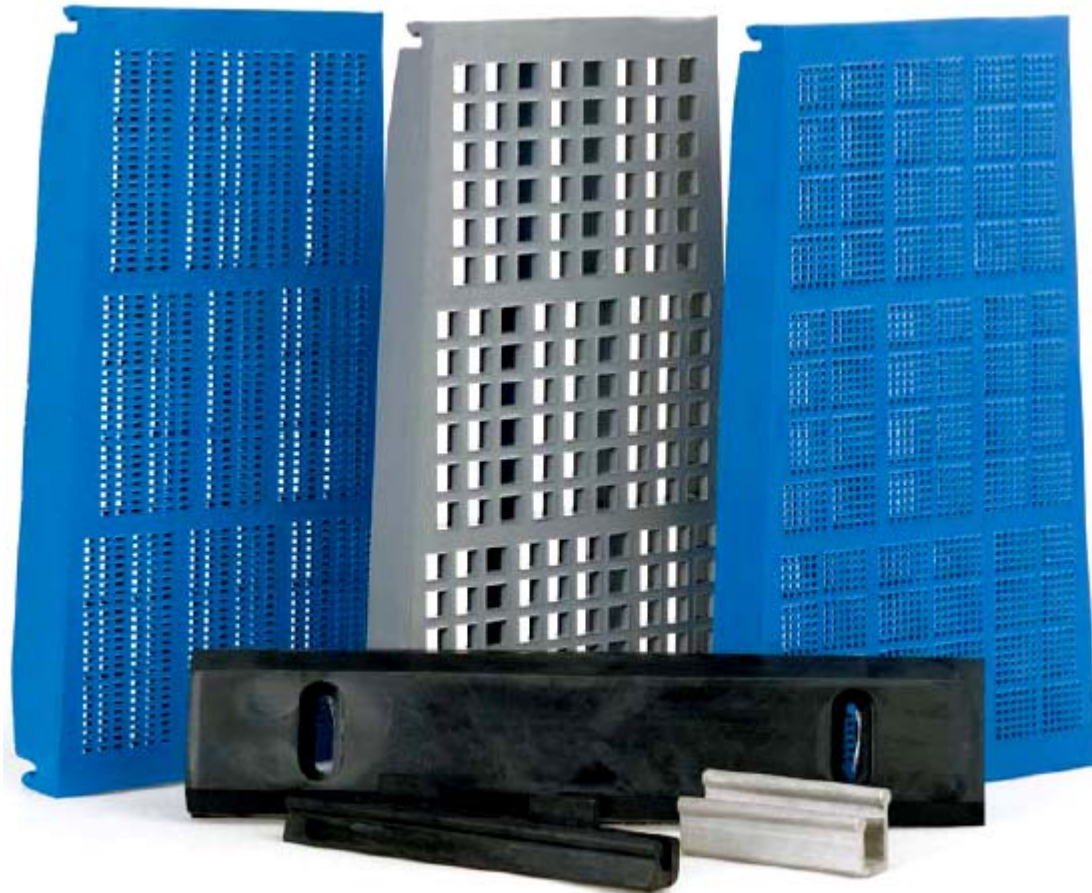

Screening Media – Rubber

A modular screening media for fine to medium coarse screening in dry applications.

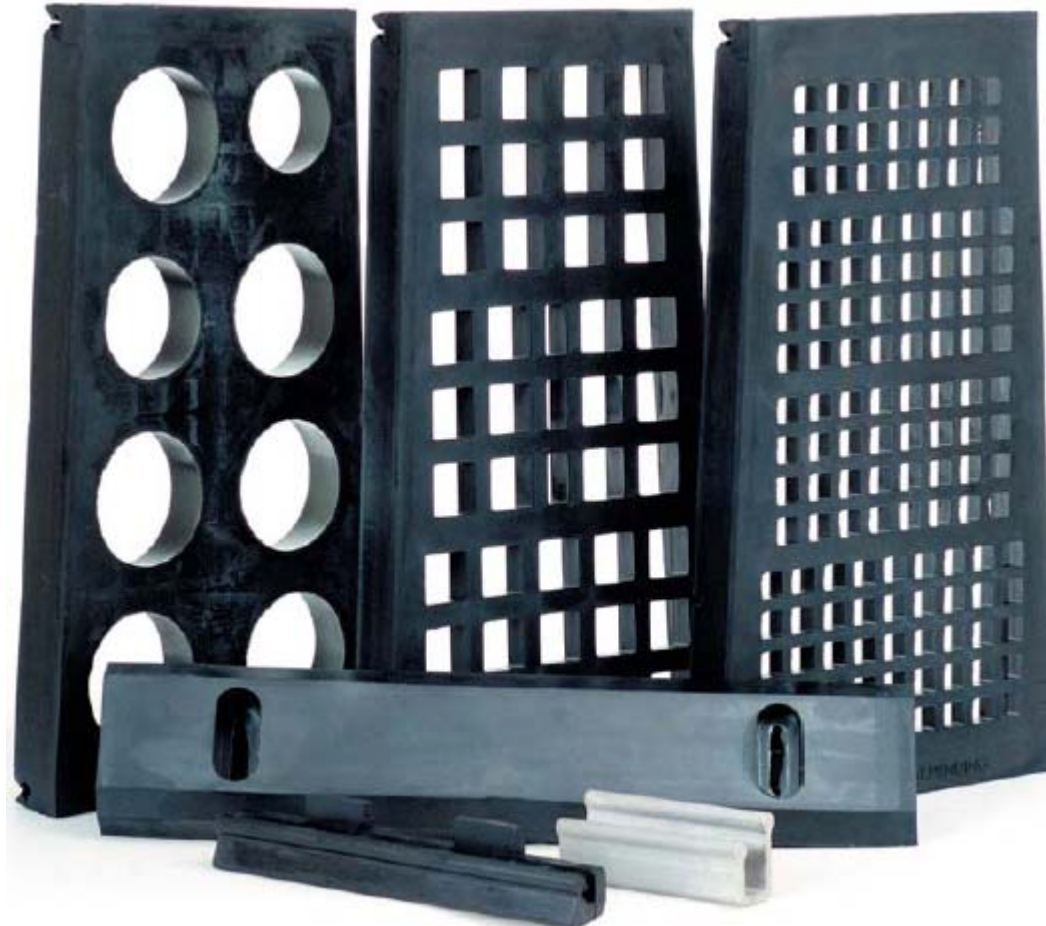

Screening Media – Rubber (40 Duro)

A modular screening media of soft rubber for fine screening in difficult applications.



Screening Media – Synthetic PU or Rubber

Tensioned PU or rubber screening media for fine to medium coarse screening in wet or dry applications.



Screening Media Selection Guide

| | Modular rubber screening media | Modular anti-blinding screening media | Modular PU screening media | Tensioned anti-blinding PU screening media | Tensioned rubber screening media | Tensioned PU screening media | Pre-tensioned rubber screening media | Pre-tensioned PU screening media | Flat self-supporting rubber screening media | Self-supporting rubber screening media with skidbars | Special screening media |
|--|----------------------------------|---------------------------------------|----------------------------------|---|---|------------------------------|--|--|---|--|---|
| Screening duty | Intermediate and final | Final | Intermediate and final | Final | Intermediate and final | Intermediate and final | Secondary, Intermediate | Intermediate and final | Primary, secondary | Primary, secondary | Final |
| Max feed size (mm) | 20 - 150 | 10 - 50 | 10 - 100 | 20 - 50 | 20 - 150 | 10 - 100 | 30-250 | 10 - 100 | 150 - 300 | 75 - 400 | 10 - 50 |
| Separation | 10 - 63 | 2 - 16 | 1 - 31,5 | 2 - 16 | 5,6 - 63 | 1 - 45 | 16 - 90 | 1 - 45 | 45 - 120 | 45 - 120 | 2 - 25.4 |
| Application | Dry | Dry / anti-blinding | Wet / dry | Dry / anti-blinding | Dry | Wet / dry | Dry | Wet / dry | Dry | Dry | Wet / dry / anti-blinding |
| Dewatering | No | No | Yes | No | No | Yes | No | Yes | No | No | No |
| Deck design | Special | Special | Special | Cambered | Cambered | Cambered | Cambered | Cambered | Flat | Flat | Special |
| Panel type | Modular | Modular | Modular | Tensioned | Tensioned | Tensioned | Pre-tensioned | Pre-tensioned | Self supporting | Self supporting | Special |
| Material | Rubber | Soft rubber | Polyurethane | Soft Polyurethane | Rubber | Polyurethane | Rubber | Polyurethane | Rubber | Rubber | Polyurethane |
| Aperture | Moulded and punched | Punched | Moulded | Punched | Punched | Moulded | Punched | Moulded | Moulded and punched | Moulded | Punched |
| Most common thickness (mm) | 8, 11, 15, 20, 25, 30, 35 and 45 | 2.5, 3.5, 5.5, 8, 11 and 15 | Hole size dependent | 2.5, 3.5, 5.5 and 8 | 5, 7, 10, 12, 15, 20, 25, 30, 35, 40 and 50 | Hole size dependent | 15, 20, 25, 30, 35, 40, 50 and 60 | Hole size dependent | 40, 50, 60 and 70 | 55+20, 70+50 and 70+60 | 2, 3, 4, 5, 6, 7, 8, and 9 |
| Fastening | Snap-on | Snap-on | Snap-on | Cross- or length tensioned | Cross- or length tensioned | Cross- or length tensioned | Clamp down | Clamp down | Clamp down | Clamp down | Wedged or bolted depending on screen design |
| Accessories | Side liner and side liner spacer | Side liner and side liner spacer | Side liner and side liner spacer | Centre hold down, Centre hold down spacer and Capping | Centre hold down and Capping | Centre hold down and Capping | Side hold down, Centre hold down and Capping | Side hold down, Centre hold down and Capping | Side hold down and Centre hold down | Side hold down and Centre hold down | Wedge |
| Bulk density max. 1.8 metric ton/m ³ If your application falls outside the limits specified above, please contact your Sandvik Mining & Construction representative. | | | | | | | | | | | |

Wear Protection in the Feed Box, Discharge Lips and Side Liners

- AR steel
- Steel-backed rubber
- PU
- Ceramics

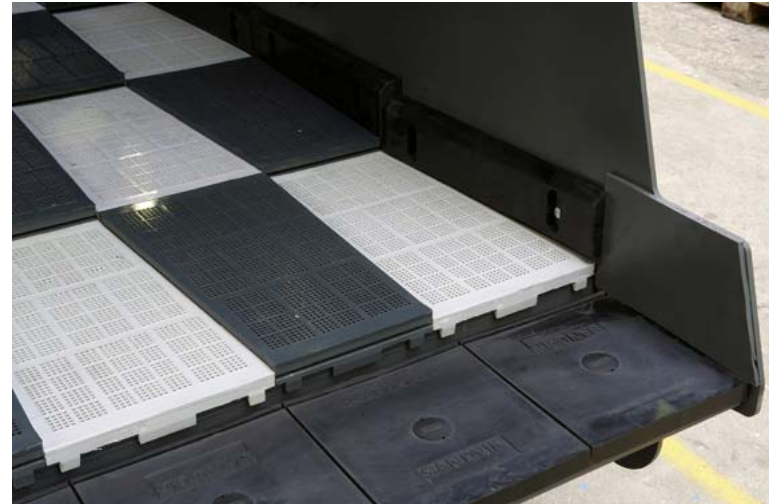
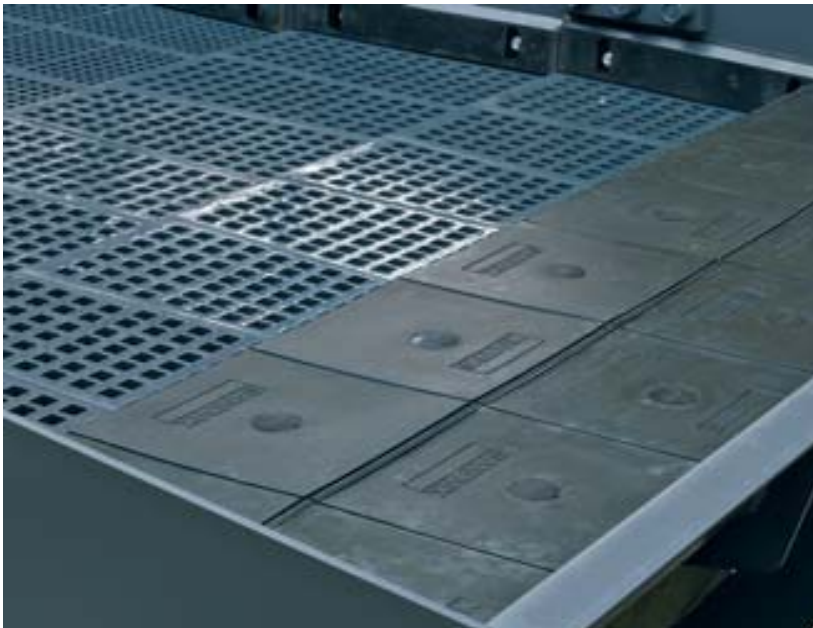

Wear Protection for Feeders and Hoppers

- AR steel
- Mild Steel
- Rubber and steel backed rubber
- Cast or fabricated grizzly bars



Options: Dust Encapsulation

- Safety
- Good neighbor
- Sound
- Dust

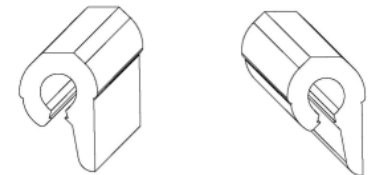
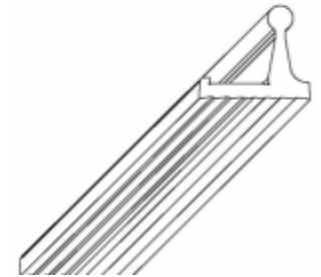
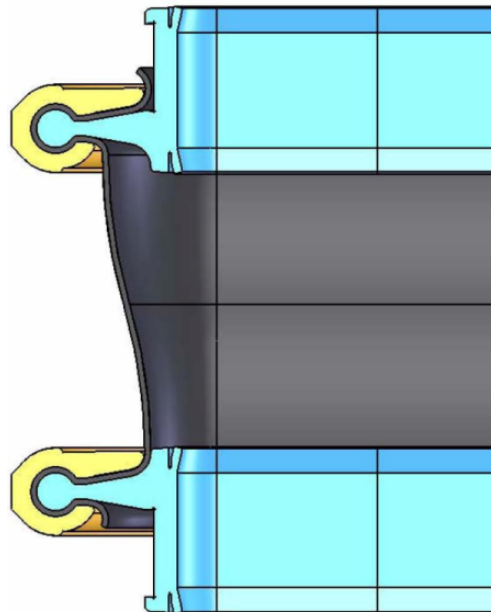
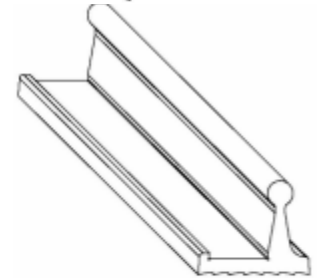
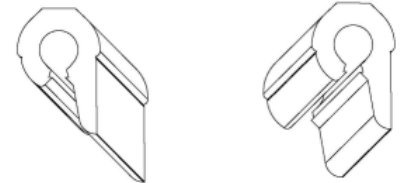
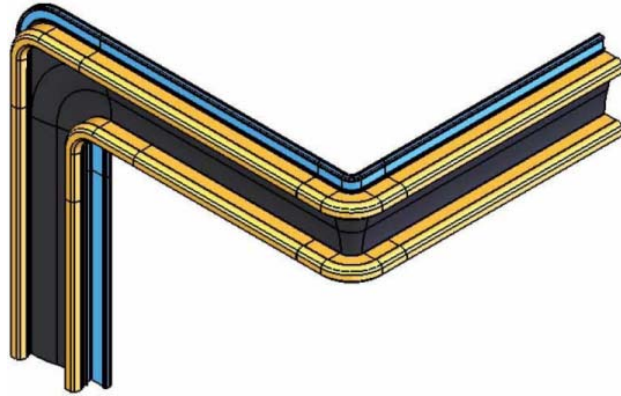

Options: Spray System

- Wash – clean – spec stone
- Stationary or live mounted
- Rule of thumb:
 - 4-6 gpm / ton of feed

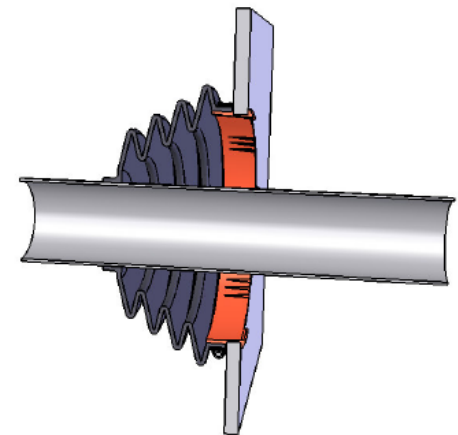
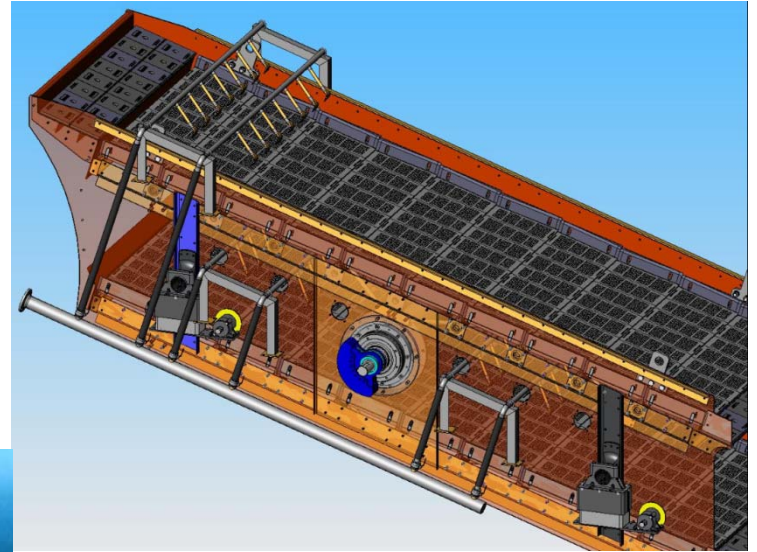

Options

- Base Frame
- Media
- Cardan shaft drive
- Liners
- Motor(s)
- Special paint or coating
- Steel structure.....



Steps to Improving Screen Performance

- Identify the improvement you want or determine the problem that you have with your vibrating screen.
 - *Examples: Increase tph, improve screen efficiency, cleaner product, reduce re-circulating load...*
- If you have a new problem, determine if something has changed in the circuit, material characteristics, crusher setting, screen opening, screen speed and stroke.
- Gather specific application data as it applies to that unit and seek assistance from the manufacturer or dealer.

Solving Plugging and Blinding with Speed & Stroke

- Make sure you have the correct speed & stroke for the openings. There is normally a speed & stroke adjustment which can be made to help.
- For plugging, increasing the stroke normally helps to kick out the near size or elongated material.
- For blinding, increasing the speed normally helps and sometimes increasing the stroke also helps. Sometimes blinding problems start out as plugging problems.

Always consult with the factory before making any changes!

Determining Speed & Stroke

Speed: Electronic RPM Meter

OR

Drive sheave dia. divided by driven sheave x motor RPM.

Example:

Motor sheave 5", Screen sheave 11", Motor RPM 1750

5 divided by 11 = .455 x 1750 = 796 RPM

Stroke: Stroke Card

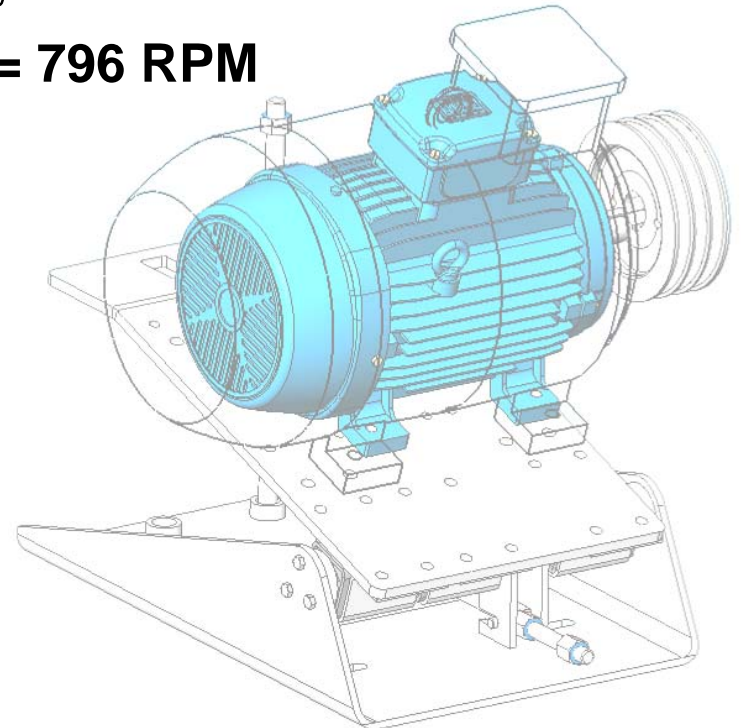
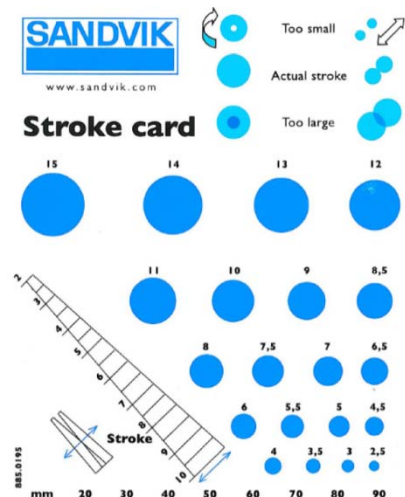

V-Belt Drive

- Check alignment of sheaves. Shafts must be parallel.
- Maintain uniform tension. When idle, belts should appear snug. In motion, there will be a slight movement on slack side when using a pivoted motor base.
- Keep drives well ventilated. Avoid heat build-up.

V-Belt Drive

- Use new belts of the same make.
- Always use matched sets of belts – never mix.
- Never use belt dressing.
- Worn sheaves reduce belt life. Check sheaves frequently.
- Oil Carefully. Excessive oil on belts causes rubber to swell and belts to fail prematurely.
- Never force belts onto sheaves. Release take-up.

Start-up / Commissioning Form

| | | | | | |
|---|---|------------------------------------|---|--------------------------------|--------------------------|
| Customer Representative/Title _____ Phone _____ |  | | | | |
| Address _____ | | | | | |
| City, State, Zip _____ | | | | | |
| Sandvik M & C Distributor | | | | | |
| Contact _____ Phone _____ | | | | | |
| Application: <input type="checkbox"/> Rock <input type="checkbox"/> Gravel <input type="checkbox"/> Recycling Ambient Temperature: _____ °C _____ °F | | | | | |
| A. Prior to actual starting of screen: | | | | | |
| | OK | NOTE | | OK | NOTE |
| 1.a. Oil level | <input type="checkbox"/> | <input type="checkbox"/> | 5. Screen rotating proper direction for application | <input type="checkbox"/> | <input type="checkbox"/> |
| 1.b. Oil sight glass in proper location | <input type="checkbox"/> | <input type="checkbox"/> | 6. No load amps _____ | <input type="checkbox"/> | <input type="checkbox"/> |
| 1.c. Type of lubricant | <input type="checkbox"/> | <input type="checkbox"/> | 7. Water spray provisions | <input type="checkbox"/> | <input type="checkbox"/> |
| 1.d. Check appropriate grease filling locations | <input type="checkbox"/> | <input type="checkbox"/> | 8. Platform and guards | <input type="checkbox"/> | <input type="checkbox"/> |
| 2. Screen cloth tightness | <input type="checkbox"/> | <input type="checkbox"/> | 9. Slope angle | <input type="checkbox"/> | <input type="checkbox"/> |
| 3. Foundation design adequate to support screen | <input type="checkbox"/> | <input type="checkbox"/> | C. Operation performance loaded | | |
| 4. Adequate clearance from chute and structure | <input type="checkbox"/> | <input type="checkbox"/> | 1. Even feed distribution | <input type="checkbox"/> | <input type="checkbox"/> |
| 5. Proper chute design to prevent build up | <input type="checkbox"/> | <input type="checkbox"/> | 2. Feed size max _____ min _____ | <input type="checkbox"/> | <input type="checkbox"/> |
| 6. Screen installed level | <input type="checkbox"/> | <input type="checkbox"/> | 3. Loaded amps _____ | <input type="checkbox"/> | <input type="checkbox"/> |
| 7. Tighten loose bolts or wedges | <input type="checkbox"/> | <input type="checkbox"/> | 4. Bearing temperature normal | <input type="checkbox"/> | <input type="checkbox"/> |
| 8. Springs vertical at horizontal support | <input type="checkbox"/> | <input type="checkbox"/> | 5. Approximate bed depth | <input type="checkbox"/> | <input type="checkbox"/> |
| 9. Proper alignment of motor sheave in relation to drive sheave | <input type="checkbox"/> | <input type="checkbox"/> | 6. Material flow rate _____ | <input type="checkbox"/> | <input type="checkbox"/> |
| 10. V-belt tension correct | <input type="checkbox"/> | <input type="checkbox"/> | 7. Indicator cards for motion | <input type="checkbox"/> | <input type="checkbox"/> |
| 11. Bin level indicator if mounted directly over bin | <input type="checkbox"/> | <input type="checkbox"/> | 8. Feed rate checked: Constant _____ Surging _____ | <input type="checkbox"/> | <input type="checkbox"/> |
| ACCESSORIES | | | 9. Cloth size | <input type="checkbox"/> | <input type="checkbox"/> |
| Automatic lubrication unit | | | Top _____ 2nd _____ 3rd _____ 4th _____ | | |
| 12. Check adjustment | <input type="checkbox"/> | <input type="checkbox"/> | 10. Feed analysis checked | <input type="checkbox"/> | <input type="checkbox"/> |
| 13. Check grease outflow | <input type="checkbox"/> | <input type="checkbox"/> | D. Operation training | | |
| 14. Check hose fixings and linings | <input type="checkbox"/> | <input type="checkbox"/> | 1. Training of safety issues | <input type="checkbox"/> | <input type="checkbox"/> |
| B. Screen no load operation observation | | | 2. Operating the screen | <input type="checkbox"/> | <input type="checkbox"/> |
| 1. RPM | <input type="checkbox"/> | <input type="checkbox"/> | 3. Daily maintenance of the screen | <input type="checkbox"/> | <input type="checkbox"/> |
| 2. Stroke correctly for application amount _____ | <input type="checkbox"/> | <input type="checkbox"/> | 4. Name / Company of attendees in training | | |
| 3. Counterweight setting | <input type="checkbox"/> | <input type="checkbox"/> | a. _____ | | |
| 4. No oil leaks | <input type="checkbox"/> | <input type="checkbox"/> | b. _____ | | |
| NOTES: _____ | | | | | |
| (Please additional notes on back of this paper) | | | | | |
| Customer _____ | Date _____ | SMC/Distributor Service Eng. _____ | Date _____ | SMC Service Manager Date _____ | |



Daily – Weekly – Monthly: Safety and service check list

Maintenance Check List

- Establish a maintenance schedule based upon manufacturer's recommendation.
- Set a daily time period and routine for lubrication, inspecting cloth for condition and tension, inspection of cloth support rubber, etc.
- Do not inspect or lubricate vibrating equipment that is running.
- Check all bolted connections for proper torque on a routine basis.
- Use check-off lists to aid in insuring completion of maintenance duties. Keep good maintenance records.

Maintenance Check List

Before Start-up:

- Check the screening surface for material build-up. Starting with excessive material on the screen deck may damage the vibrating screen.
- Check the screening surface for breaks or worn areas.
- Make sure there is a 2” minimum clearance between any part of the body and any stationary chute, hopper, or any of the support structure. Guards in-place.
- Pay particular attention to oil levels, breathers, pumps, line strainers, warning signals, and pressure hose assemblies. Refer to manufacturer’s manuals.

Safe Installation Procedures

READ THE MANUFACTURE'S INSTRUCTION BOOK FIRST.

- Safety always.
- Select crane or hoist and lifting tackle based on manufacturer's weights for screen.
- Provide means for hoisting and handling largest usual repair part.
- Provide adequate clearance and headroom for making repairs.
- Provide means for handling wire cloth, or other screening surfaces.

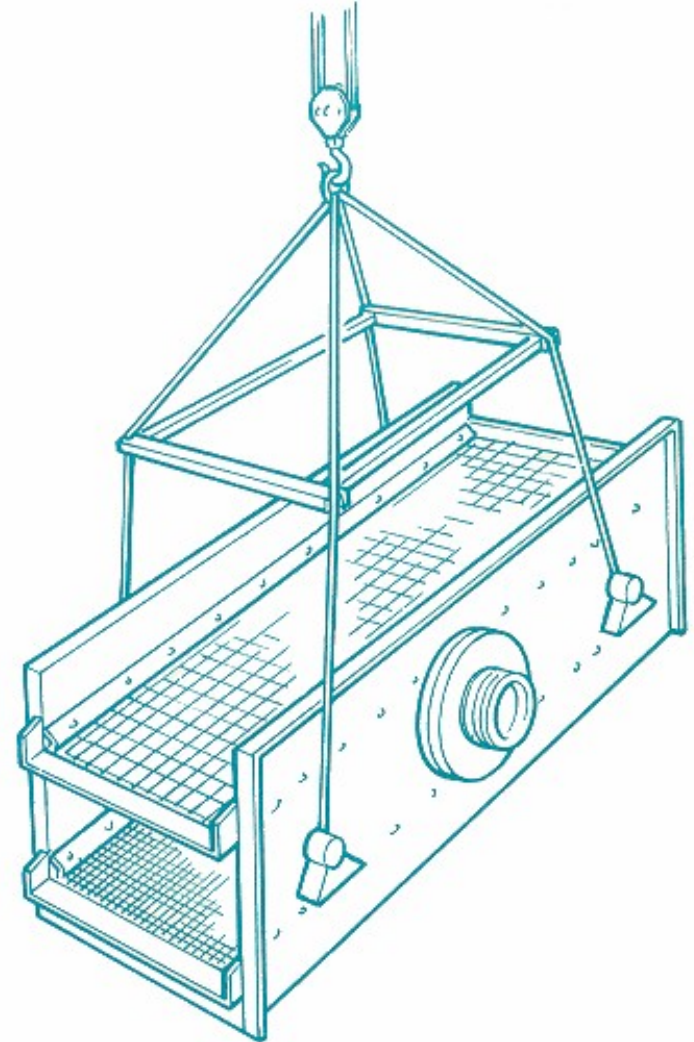

Safe Installation Procedures

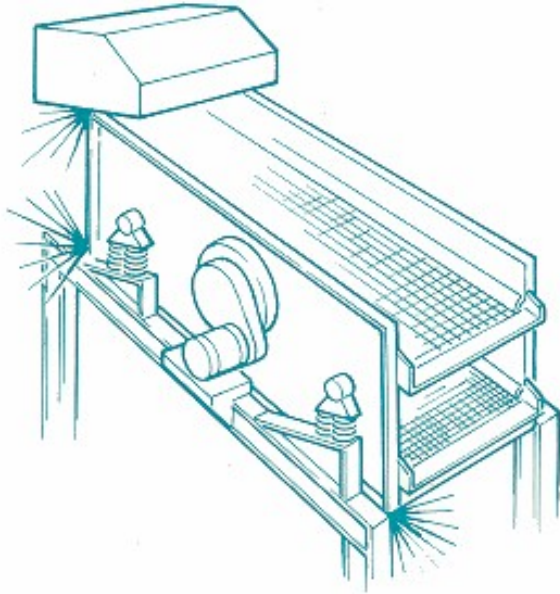

- Check complete installation for compliance with all Federal, state and local regulations for ladders, walkways, rails and platforms, color coding, hazard warnings, guarding, enclosing drives and rotating parts.
- Do not weld any attachments onto screen body or base without consulting the manufacturer.

Off-Motion and Critical Speed

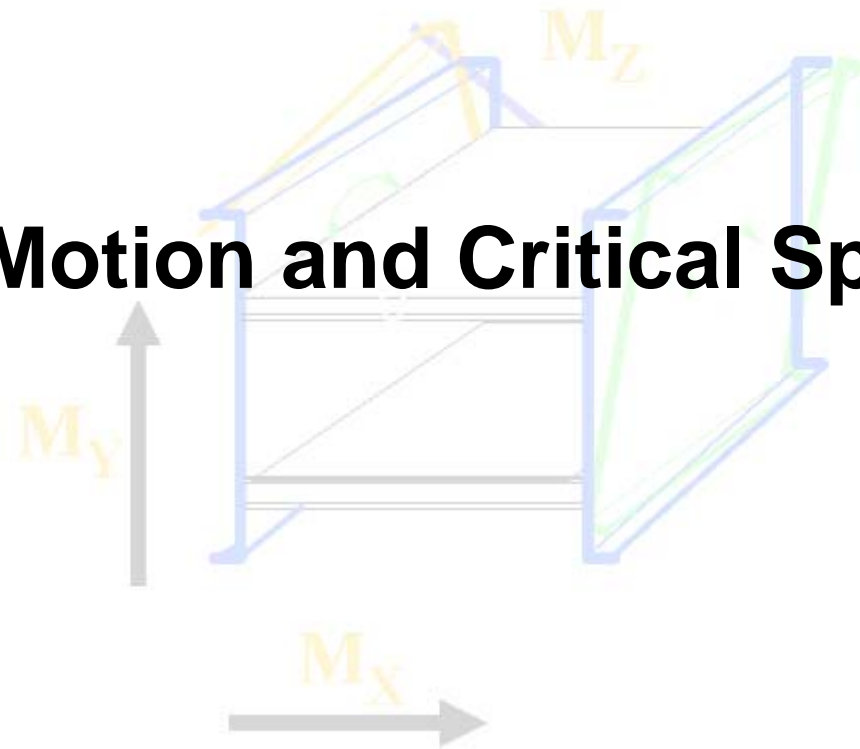

Off-Motion and Critical Speed

Model name: XS144_FEM4_empty_test12
Study name: frek
Plot type: Frequency-Plot1
Mode Shape : 7 Value = 14.827 Hz
Deformation Scale: 26.9813

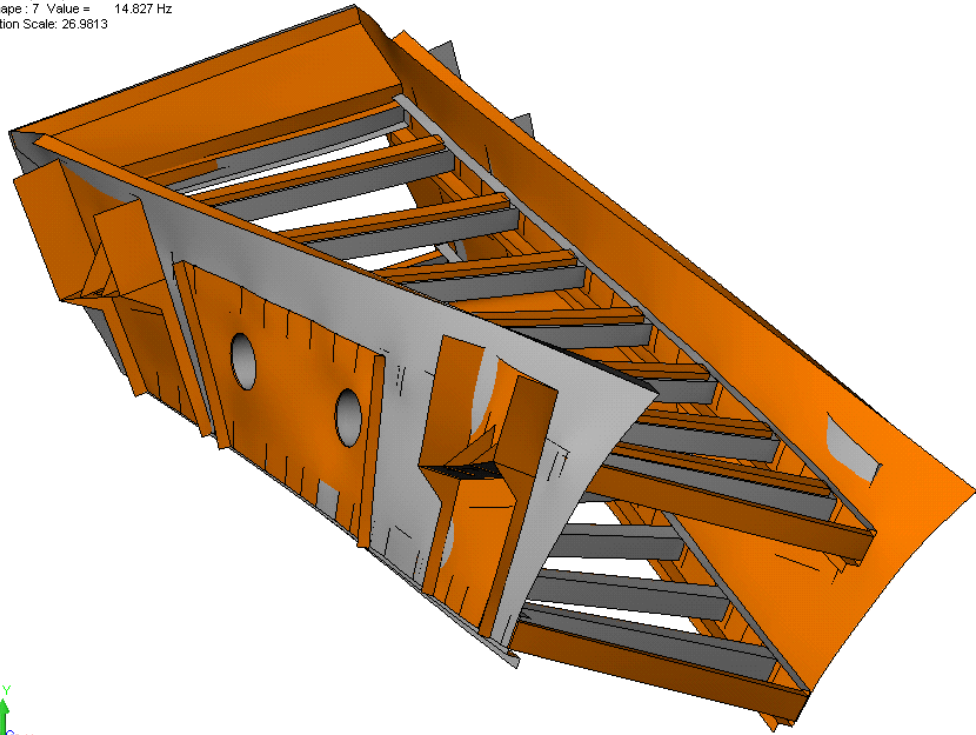

Off-Motion & Critical Speed

What is Off-Motion?

- When the vibrating screen of feeder is not going through its true design motion but instead is running with severely distorted and varying motions throughout the body of the unit.

How to check for Off-Motion?

- Select an area on the side plates and observe the motion pattern.
- Check for “mirror image” pattern, one side compared to the other.
- Stand at the end of the of the vibrating unit and determine if all frame members are moving straight up and down rather than at a sideways angle.

What is Critical Speed?

- Each screen body has its own natural frequency. If the machines operational frequency is too close to the natural frequency the stress can cause off-motion and reduce the life of the screen.

What Causes Off-Motion?

- Unit not installed level (unequal corner spring deflection).
- Broken / worn springs or rubber mounting units.
- Loose fasteners.
- Material build-up on deck or decks.
- Side loading.
- Overloading.
- Plugging and blinding.
- Speed.
- Inadequate support structure.
- Inadequate body design.
- V-Belt tension.
- Vibration dampening adjustments.

Conclusion

- This information was presented to provide you with information to promote a safer, more cost efficient operation.
- My best advice is safety first. When a screening issue arises, always look for the obvious (broken spring, belt too tight, broken cross member, loose bolting hardware).

www.quarryacademy.com



LIGHTEN UP!