

NEW DEVELOPMENTS IN STANDBY SEALS FOR APPLICATIONS FOR ENVIRONMENTAL SENSITIVE DUTIES

by

Jeremy M. Heatley

General Manager

and

Matthew Giffrow

Mechanical Seals Support

Flexibox, Incorporated

Houston, Texas



Jeremy M. Heatley is Vice President and General Manager of Flexibox Incorporated and is responsible for all operations in both the United States and Canada.

Mr. Heatley has gained a wide range of practical experience in both mechanical seals and power transmission couplings during 22 years in service with Flexibox in Manchester, England, Toronto, Canada, and during the last two years in

Houston working in various areas of company's operations.



Matthew Giffrow began his career at Flexibox while studying at the University of Houston. He has been involved in the Engineering, manufacturing, and sales aspects of the mechanical seal industry.

Mr. Giffrow's primary functions now are providing technical support to the Flexibox sales group, and to analyze and provide technical service on seal failures. He has been with Flexibox since 1978.

ABSTRACT

Over the years, close attention has been paid in process facilities to the pumping of light hydrocarbons. Leakage of these products can and do cause environmental and health threatening situations. Since attention has been paid in the past, and at the present time, legislation has been passed to limit product emissions. Even more stringent regional and national limits are being debated that could have far reaching effects in the refining and petrochemical industries.

The problems of viable mechanical seal designs for light hydrocarbons are addressed. Effective types of seals used on light hydrocarbon duties are outlined. The advantages and disadvantages of using single, tandem, and double seal designs on these duties will be discussed.

The criteria set up by the Environmental Protection Agency and the South Coast Air Quality Management District can be a researcher's nightmare, but herein, these guidelines, and how they apply to the mechanical sealing industry, are addressed. How the different types of seals; single, tandem and double do or do not meet EPA and SCAQMD limits are addressed.

Finally, the design and development of a dry running mechanical seal which meets emissions requirements and is a viable economical and technical alternative to liquid tandem seals is discussed.

SEAL LIGHT HYDROCARBONS

Aside from being difficult to effectively seal, light hydrocarbons can be very dangerous to the environment and the people in the environment. This puts extra pressure on seal manufacturers to continuously look at ways to keep leakage to a minimum.

As a rule, mechanical seals must have a stable fluid film between the rotating and stationary faces to run effectively. This fluid film lubricates the rubbing faces and provides sufficiently low coefficients of friction so that continual running is achievable without giving way to too much face wear or excessive heat generation.

The seal faces are loaded together by mechanical force via springs and hydraulic acceptance designed into the seal. These loads work in conjunction with hydrodynamic, hydrostatic, and mechanical forces via asperity contact.

The end result of the mechanical and hydrostatic loads on the faces in a properly operating mechanical seal is leakage which is far below operating leakage limits. However, by the nature of different designs, some seals generate more heat around the faces than others. As critical as this is on conventionally simpler duties, it is doubly critical on light hydrocarbon duties.

With heat being generated around the seal faces, the temperature of the product climbs closer towards its boiling point. If the fluid film between the faces reaches its boiling point, it turns to vapor which damages the seal faces, and eventually causes premature seal failure. It is, therefore, of utmost importance on light hydrocarbons to maintain stable operation of the product.

Light hydrocarbons normally are pumped at temperatures which do not leave much room for heat rise across the seal faces. Because of this, special consideration has to be given to seal face materials and loading on the faces. A typical temperature rise for a 2.75 in seal traveling at 3000 rpm is right at 68°F. As can be seen, this type of rise on light hydrocarbon duties can be quite risky.

By knowing the sealed pressure of any particular light hydrocarbon, the boiling point of that specific duty can be determined. To correctly select a seal, the pumped product temperature should also be known. By having the sealed pressure and temperature of the product the margin of the boiling point and pumping temperature can be determined. This particular margin is commonly referred to as the "ΔT available" of the application.

Sometimes the ΔT is not recognized as sufficient for a particular application. It is the responsibility of the seal manufacturer,

given that the user has supplied him with sufficient correct information, to bring the ΔT to an acceptable level. If an insufficient ΔT has inadvertently been used in the selection process, or if the user has provided incorrect duty details, the chance of product leakage to atmosphere because of mechanical seal failure is greatly increased. This failure could come in the form of product vaporization at the seal faces, or dry running of the seal causing excessive face wear. Either of these symptoms most assuredly gives rise to premature seal failure.

To achieve a satisfactory ΔT , there are a number of options. Using coolers in the circulation line, using cooling jackets, even increasing the pressure that the seal is exposed to are ways that a safe operating curve can be achieved.

EMISSIONS STANDARD AND CONTROL

Leakage of emissions to the atmosphere is no longer acceptable. Legislation has been passed at federal level and is administered by the Environmental Protection Agency (EPA). Several states are also considering or have passed their own regulations. One such example is California's South Coast Air Quality Management Board (SCAQMB).

EPA standards are such that any pump or compressor with leakage measured in excess of 10,000 parts per million (ppm) is in violation. However, in the case of SCAQMB, there has been an amendment that for those plants under their jurisdiction. The maximum allowable level could be as low as zero for new pumps and 1000 ppm for existing installations.

Following is a general guide as to what the requirements are that a plant operator has to meet in regard to the use of pumps and compressors in refineries and chemical plants using SCAQMB standards (reg. -Precursor Organic Compounds). It probably will not be very long before similar such standards are put into place in such states as Texas and Louisiana.

What does the Regulation Cover?

Any pump or compressor service with a Reid Vapor pressure of more than 1.5 psia (78mm HG) is covered by the regulation.

What are the Standards?

Any pump or compressor is in violation if there is leakage or emissions in excess of 1,000 ppm measured at a distance of one cm (0.4 in) from the shaft and seal plate (gland) junction.

Any new pump or compressor put into service must have zero emissions. Any pump or compressor rebuilt and put into a new service must have zero leakage.

Essential and Nonessential Items (Rule 301.1-SCAQMB)

Essential Items

Essential pumps and compressors are those which if taken out of service would reduce the production capacity of a particular process unit by more than 33 percent. Otherwise, the equipment is defined as nonessential. All essential items must be registered as such and identified accordingly. All essential pumps and compressors must be measured for emissions at least once a year. Any new essential equipment must be measured within seven days of installation. In addition, all essential pumps and compressors must be visually inspected every seven days.

Nonessential Items

Any pump or compressor with a leak in excess of 1,000 ppm must be removed from service for repair within seven days. If a spare pump or compressor is then used and found to be in violation, repairs for that item must be completed within 30 days. If during the weekly visible inspection a leak is noticed a measurement must be taken within two days.

When an essential pump or compressor is found to have leakage in excess of 1,000 ppm, the leak must be minimized within 15 days. The equipment must then be repaired during the next scheduled turnaround of that particular process unit. The equipment must also be reinspected 15 days after the leak is minimized.

Record Keeping

Records of all measurements must be kept for two years. A list of all essential pumps and compressors must be maintained. Items that are awaiting repair must be tagged and clearly identified.

The regulation does not specify the type of sealing method. The regulation only specifies the leakage limits. It is in the best interest of every plant maintenance manager to ensure that all applicable operations personnel are aware of what the regulations say and to understand what the regulations mean.

It is essential that everyone involved with the operation and implementation of the standards is fully aware of how seals and their related systems work. They should be able to determine and understand the causes of seal failures. They should also be aware of how to rectify the sealing problem once a problem occurs. The very tight limits set forth will be difficult to achieve, but with the cooperation of the seal manufacturer and the industrial user, they can be obtained.

As we have seen the limits being established for emissions are becoming more and more stringent. Even before those limits came to be, there already was widespread interest in developing more efficient secondary sealing devices. The new regulations are now expediting the research and development process. Seal manufacturers are working closely with users in developing acceptable secondary sealing designs. Currently there are three ways to achieve primary seal security and secondary sealing safety.

MULTIPLE SEAL OPTIONS

Double seals are generally the most secure seal design for products which can withstand contamination of sealed fluid by the barrier fluid. However, if the sealed product can accept zero contamination by the barrier fluid, then double seals are not the way to go. Most light hydrocarbons can ill afford barrier fluid leaking into the system. This can cause all sorts of environmental problems, not to mention the economic penalties. Also, the problem of constant maintenance of a pressurized barrier fluid system is something most users would probably like to do without. Not only maintenance, but the cost of purchasing one of these systems is hard to swallow. Double seals; therefore, may not be the only seal of choice on light hydrocarbon duties.

The second option of secure secondary sealing designs is the liquid tandem seal. In terms of cost, liquid tandem seals are between single seals and double seals. This puts them somewhere up to ten times as much as a single seal after taking into account brackets, concrete bases, pipework, seal pots, and most importantly, the cost of maintaining the system.

The idea of a tandem arrangement is that the inboard seal runs on pumped product, and the outboard seal runs on a clean cool barrier fluid. By doing so, there is no possibility of product contamination by the barrier fluid. The outboard seal is designed to have the same design capabilities as the inboard seal. In the event of primary seal failure, the outboard seal can handle the onset of leaked product.

Because the tandem arrangement is fitted with a seal pot, it is possible to monitor any leakage of the primary seal and the condition of the outboard seal, by monitoring the level of liquid in the pot. The barrier fluid also assists in heat dissipation from the inboard seal by virtue of the fact that the clean cool barrier

fluid is constantly circulating on the underside of the inboard faces. This also prevents any product icing at atmosphere.

Liquid tandem seals are a viable solution to sealing of light hydrocarbons. They do have two significant drawbacks, however, cost and space required to fit them (Figure 1).

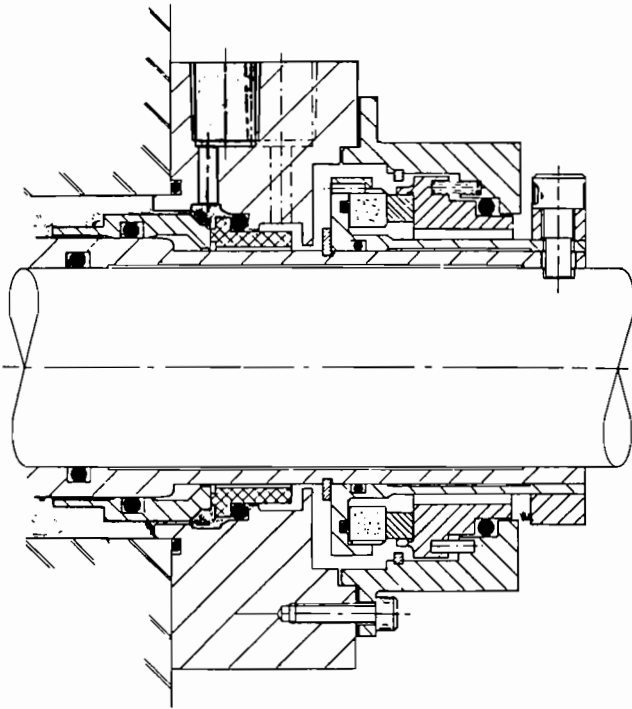

Figure 1. Typical Tandem Seal Arrangement.

DRY RUNNING STANDBY SEALS

It is to this end that the continued development of a reliable alternative has been very actively pursued.

Being able to provide a tandem seal arrangement without needing any barrier fluid systems would provide the user the optimum situation: secondary sealing safety without the worries or cost of systems and their inherent maintenance needs.

This idea sounds ideal, and it can be done, as we will see in the development of a dry running full face contacting mechanical seal.

The dry running standby seal must be capable of running for long periods completely dry. It must also however, be capable of handling intermittent wet and dry pressures and, most importantly, the seal must be able to handle full product pressure in the event of complete failure of the primary seal.

There have been dry running seals introduced before such as seals with hydrodynamic grooves cut into the seal faces. These seals by definition run on gas films and give correspondingly high gas leakages. This can be particularly hazardous for products containing toxic or inflammable fractions. Also, when the product is prone to form waxy deposits, hydrodynamic grooves can be blocked, thus reducing the efficiency of the seal.

This design of full face contacting standby seal has been subjected to extensive development. During these various testing procedures, both at the research and development facilities, and by actual industrial users, the seal has met the demanding requirements set by a number of international oil companies.

At the initial design stage of the seal, some specific parameters were set forth. First, the seal must be capable of running com-

pletely dry at zero pressure for a period of at least 10,000 hr continuously. This is over one year which, on many duties, is longer than the inboard seal may actually operate.

The seal must be capable of running on dry air at a pressure of 30 psi for a minimum of 1,000 hr. This length run is normally slightly less than typical alarm pressure, and allows the user time to schedule proper pump shutdown to check all the pumping systems operating parts (bearings, piping, etc.). This is over a one month period.

The seal must be capable of running on liquids up to 600 psi for at least one hr. This gives the operator the security of knowing he has time to execute a controlled shutdown of that particular pump without having to drop whatever he is doing at that particular moment.

The seal must be able to be periodically checked for its sealing integrity and this check can be done by hooking up pressure gauges to show any primary seal leakage cavity between the two seals. A medium can also be induced into the seal cavity at a given pressure for a specified period of time, to give the user confidence that the seal is still operating at full efficiency.

As suggested by its name, the seal's faces are always in contact and held that way by nominal spring pressure. There is, therefore, a requirement to use the optimum seal face materials to control frictional heat generation and wear. Initial testing was aimed at evaluating a number of different materials under a number of face loading conditions. A number of different results were achieved.

The results of this testing identified a sprayed tungsten carbide rotary face *vs* a PTFE filled carbon as the best combination. The initial design of seal using this material combination proved to be unstable at high pressures following extended low pressure running. The problem was concave conical distortion of the carbon seal ring which allowed the seal to blow open when high pressure was applied, due to the over balancing of the seal.

The seal design was modified, as shown in Figure 2, to give the seal more stability during pressure variations. By 1983, silicon carbide had become more readily available and was chosen as the rotary seal ring material, following extensive testing and successful use on dry running seals for top entry mixes and coal cutting machine seals. The stationary face was modified to use a carbon material best suited for dry running applications.

Since this seal operates continuously in a contacting mode, it was vital to attain the correct compromise between face area, balance ratio and spring load. This compromise needed to produce low enough wear rates to give required life, but also provide stability during all modes of operation. In order to attain low wear rates, the spring load has been kept to an absolute minimum.

While increased face widths would give longer life at zero running pressure, it would inevitably produce much higher heat generation when running under pressurized conditions. It was vital to minimize spring loads, so it became even more important to concentrate on reducing the frictional drag in the secondary O-ring element. By careful adjustment of the O-ring hardness and its compression, it was possible to produce extremely low frictional levels which were reliable and repeatable. Careful attention was given to the fixing of the carbon face in its housing, so as to give minimal thermal and pressure distortions, and of course, secure retention under all operating conditions.

This development and testing has been very carefully monitored by, and with co-operation of, some international oil companies.

Under dry air conditions the seal is in effect, a dry bearing, and lifetime is a function of wear rate. Extended wear tests were performed at a number of different pressures. Wear at zero pressure on dry air was established in our laboratory at 16,000 hr minimum operation for a three inch size seal at 3000 rpm.

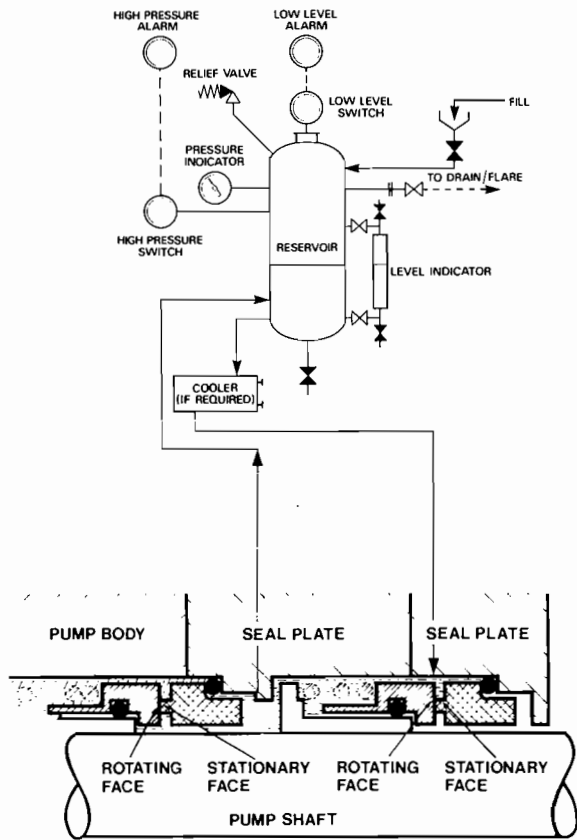

Figure 2. Typical Standby Seal Arrangement.

The seal was then run on nitrogen at seven psi to establish likely lifetimes under pressure expected, if the seal were vented to flare. These tests came out to around 15,000 hr operational life.

As stated earlier it was important to establish minimum lifetimes near the typical alarm pressure (test cases were 25-30 psi). The 1000 hr minimum was attained. Actual figures in testing were between 1200 and 1800 hr at alarm condition.

Formal extended running tests at high pressure on dry air have not been tabulated. However, the seal on various occasions has run up to 150 psi for a number of hr without appreciable signs of heat or wear.

Again, excessive heat generation around the seal faces must be held to a minimum to achieve required running periods. Thermocouples were fitted to a carbon stationary face to show the temperature trace for a period of 13 hr at varying pressures between zero and 25 psi. For an ambient temperature of 85°F the stabilization temperature was 190°F indicating a temperature rise of 105°F, which was within the required users' limits.

The maximum recommended peripheral speed requirements of 70 ft/sec was set to satisfy three criteria simultaneously. The first was for a minimum of 10,000 hr life at zero pressure; this worked out to 81 ft/sec. The second was 1000 hr life at zero pressure; this also worked out to 81 ft/sec. The third was 1000 hr life on dry air at 25 psi; this worked out to 69 ft/sec. Therefore, the maximum speed of 70 ft/sec became a reasonable average of the three values.

An actual sequence test was run finally to assess the seal's ability to run dry and wet intermittently. The seal was initially run dry at zero pressure for 100 hr to simulate normal running in the ambient condition. It then went through a sequence of running dry at 25 psi for an overnight period, during which time the seal

got up to normal working temperature. This was followed by the introduction of cold water at 300 psi and run for two hours.

The 25 psi dry and 300 psi wet sequence was repeated four times, and the seal was then run for several weeks at 25 psi dry air with negligible leakage levels.

The test was aimed to evaluate the seal's resistance to thermal shock and its ability to stabilize seal liquids following periods of running under the quite different conditions of dry air. The liquid trials were run dead-ended, and while the seal and its immediate environment got extremely hot, there was no liquid leakage.

Since the time of that initial testing, many seals have been introduced into quite different applications, from crude oil to the very light hydrocarbons. While actual figures have not been tabulated concerning leakage volumes into atmosphere (partly because of the successes of the inboard seals), readings have been taken outside the seal cavity with good results. There have been failures of some inboard seals which have given the standby seals a "baptism by fire." On these occasions, the standby seals have all held actual full sealing pressure until the system could be shutdown. During these running periods, readings have been taken for safety guidelines, and show no product leakage to atmosphere.

There is every indication at this stage to say that the contacting standby seal will meet both EPA and SCAQMD standards; however, more extensive testing is now taking place to confirm the contacting standby seal's ability to meet these stringent standards now being put into place.

Additional development is underway on noncontacting standby seals and leakage containment systems, and in both the laboratory and field tests, the results have shown only the absolute minimum of emissions.

To compliment the standby seal, a device was developed which would warn of primary seal failure, and permit the standby seal's integrity to be checked intermittently (Figure 3).

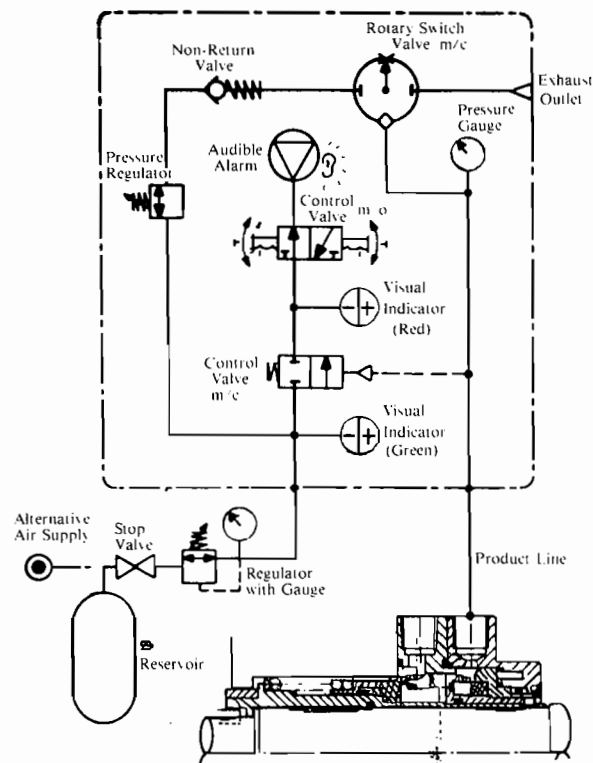

Figure 3. Leak Detector/Alarm System.

One of the design specifications recommended by the users was that the system not rely on electricity as its source of energy. This is extremely important in flammable environments, and also in remote locations where it might not be readily feasible to have a control room.

By monitoring the pressure between the primary and standby seals, the system provides both a visual and audible warning in the event of primary seal failure. In addition, it can also use the compressed gas normally used to arm the system to check that the standby seal is still operating satisfactorily.

The system is connected to the seal chamber between the primary and standby seals, and via another connection to a suitable compressed gas supply.

Should the pressure between the seals increase sufficiently due to main seal leakage, then a valve introduces the compressed gas into a pneumatic circuit causing a whistle (100 bl at 3 ft) to sound, and a fluorescent colored indicator to activate simultaneously. A pressure gauge shows the actual level of primary seal leakage.

Also, by way of a five-way valve, the compressed gas supply can be diverted into the seal chamber at a preset pressure to simulate primary seal leakage.

This allows the operator to check that the standby seal is working satisfactorily. As the gas is directed to the chamber, the pres-

sure will register on the pressure gauge. If the gauge shows the pressure holding, then the seal is working, and the pressure can be vented off. This operation can also check that the visual and audio alarms are in working order. The final advantage to this system is that more than one seal can be linked up to one alarm system.

As has been seen, the emissions limits are becoming more stringent. The development of effective ways to limit omissions has become a central issue among industrial users and mechanical seal companies. Supplying an alternative to liquid tandem seals has become an attractive idea. This idea has developed into a working dry running fully contacting mechanical seal. Based on research and actual field trials this seal has become a viable alternative to liquid tandem seals as an effective, safe secondary sealing design.

CONCLUSION

In our opinion there is now a viable option to double and liquid tandem seals for many applications that handle toxic and flammable products. The standby seals are safe, reliable and extremely economical and do not require continuous support.