

MONITORING SEALESS PUMPS FOR METAL-TO-METAL CONTACT OF THE INTERNAL ROTOR

by

Julien Le Bleu, Jr.

Senior Associate Maintenance Engineer

Olin Chemical Corporation

Lake Charles, Louisiana



Julien Le Bleu, Jr., is a Senior Associate Maintenance Engineer for Olin Chemical Corporation in Lake Charles, Louisiana. Mr. Le Bleu has over 20 years experience in the field of rotating equipment. He has worked for Olin for 13 years and is responsible for all of the rotating equipment in the company's largest chemical plant. He has worked for General Electric company as a lead technical director for the installation and maintenance of several 550 million watt turbine

generator sets. Mr. Le Bleu is a licensed aircraft mechanic and has worked on both reciprocating and jet engines. He received his Bachelor of Building Construction degree from the University of Florida (1974).

ABSTRACT

Monitoring vibration as a predictive maintenance tool will not consistently prevent catastrophic damage and/or fluid release from sealess pumps. When vibration readings are taken periodically, a pump may be destroyed between monitoring schedules. Using acceleration to monitor the internal rotor of a sealess pump does not work as well as it does on a sealed pump configuration. There are several reasons for this. First, the internal rotor mass is relatively low when compared to the rest of the pump. The external mass dampens the vibration signal and a clear interpretation is not always possible. Second, vibration generated by inconsistent fluid flow during abnormal operating conditions can create confusing vibration amplitudes. Third, sealess pumps are relatively new and experience with vibration interpretation is limited.

Monitoring sealess pumps by means other than vibration are generally reactionary, such as indicating the presence of liquid where none should be or detecting the conditions that will result in internal rotor damage. Also, some devices that monitor internal rotor condition create an additional leak path from the pump to the atmosphere. Internal rotor monitoring methods generally rely on "wearing through something" to create a signal that is detectable outside of the pump. The signal is representative of the remaining bearing life. These methods are not effective unless the internal pump wear is uniform over time. This uniformity is often lacking, because the process fluid cools and lubricates the inside of the pump and periods to reach wear limits often vary. All of the wear could have taken place in the last hour, even if the pump has been running for the last 12 months.

INTRODUCTION

There are several reasons which prevent damage detection prior to failure of a sealess pump.

- Monitoring is not continuous. Applying conventional predictive maintenance techniques does not work well for sealess pumps. Vibration amplitudes and patterns that indicate serious problems with a sealess pump would be insignificant when analyzing a conventional pump. The time between the beginning of a problem with a sealess pump and the complete destruction of the pump may be as little as a few minutes. This failure mode does not lend itself to periodic monitoring.

- Vibration monitoring is not sensitive enough or fluid flow in a sealess pump creates confusing vibration signals. Often, there is a continuously increasing one times vibration at low amplitudes, measured externally on the pump. When the amplitudes have risen high enough for good interpretation, the rotor has contacted the casing or containment shell and serious damage has already occurred. If the bearings are silicon carbide, the failure and damage can be instantaneous.

- Pump design is a factor. Consider the sealess pump design with the internal process lubricated plain bearings and external antifriction bearings with oil lubrication. The containment shell, being full of liquid, dampens vibration signals from the internal bearings which makes them difficult to receive and interpret. If the pump is running far from its best efficiency point, the interpretation problem is compounded because of fluid generated signals that are added to the mechanical vibration.

Many attempts have been made to solve the difficult problems associated with early detection of problems on the internal rotors of sealess pumps. Most of the existing "protection" methods detect conditions that will cause failure of a sealess pump or indicate that a failure has taken place. Some devices detect a drop in power consumption indicating a loss of flow or running at shutoff. Some devices indicate that a failure has occurred and allowed the pumped fluid to get out of its normal containment. Neither of these is "predictive" because operation of the pump can not continue without the threat that failure will occur soon, or that failure has already taken place.

Thermocouples contacting the containment shell are another useful protection method used in sealess pumps. However, the measuring point is not ideal. The best place to measure the temperature of the containment shell is in the middle of the magnetic drive where heat will be generated quickly on loss of cooling. This is not easily done because of limited space between the containment shell and the outer magnetic ring. Therefore, most temperature sensors are mounted near the impeller end of the containment shell and heat detection lags behind pump damage. There are also problems getting good contact between the containment shell and the temperature sensor, even with spring loaded sensors. Both of these detection deficiencies create a response time problem and do not consistently eliminate significant damage to sealess pumps.

All of these detection methods try to protect sealess pumps from their common problems. The most common sealess pump root causes are misapplication or improper operation of the pump.

These two common maladies cause the pump to cavitate, run dry, or with a solids content that can not be tolerated.

COMMON SEALESS PUMP PROBLEMS

- *Dry running.* A condition that will lead to rapid failure because fluid is not available for cooling or lubricating sealess pump internals. If the pump bearings are of silicon carbide, this condition is critical because of total bearing destruction due to thermal shock.

- *Severe cavitation.* This condition will cause the pump to fail due to overheating and potential dry running. It will take longer to damage a pump than dry running.

- *Solids in the pump.* Solids in the pumped fluid will damage the bearings, whether silicon carbide or carbon; however, carbon will wear more quickly. This condition will cause two other potential problems: First, erosion of the containment shell or torque ring; second, solids "build up" causing a reduction or blockage of cooling flow through the magnetic drive portion of the pump, resulting in its failure.

- *Thrust bearing.* Excessive wear and/or failure may be caused by solids in the pumped fluid or operating the pump at some extreme position on the pump curve. Cavitation and dry running can also cause excessive wear or failure. Thrust bearing wear will allow the pump impeller to contact the pump casing, which results in expensive damage to the pump. In addition, the potential of wearing through the pump casing exists.

- *Journal bearings.* Wear or failure of journal bearings will allow the torque ring to contact the containment shell or the impeller to contact the front or back wear rings.

The two most common failure modes of a sealess pump are thrust bearing and journal bearing wear or failure. Recent experience has shown that if a sealess pump can be stopped at the moment of metal-to-metal contact, the pump damage will be minimal. This is especially true if the bearings are a combination of soft (carbon) and hard (silicon carbide or steel) materials. This scenario may be repeated many times before a breach of the liquid containing parts occurs or serious damage results.

PUMP MONITORING METHOD

The basic monitoring philosophy was to detect metal-to-metal contact through some sort of "listening" device. If metal-to-metal contact could be detected instantaneously, the pump damage would be minimal and no breach of the containment shell would occur. When metal-to-metal contact occurs, the vibration (sound) in the metal pump components changes dramatically. The location of metal-to-metal contact within the pump is not important for detection purposes, because the vibration is transmitted to the sensor and an abrupt change in the amplitude is detected. During initial testing, some concerns were raised about gasket joints attenuating the signal. However, practice has shown that not to be the case. Perhaps the bolts transfer the sound around the gasket joint. At any rate, the signal does get to the sensor for detection.

Because of the high frequencies involved in spike energy detection, the vibration sensor should be mounted permanently. Magnetic bases and "sticks" lose too much of the signal. As mentioned earlier, continuous monitoring is required and that does not lend itself to anything but permanently mounted sensors.

TEST CONFIGURATION

The test configuration as it was applied to each pump is shown in Figure 1. The monitor, test cabinet, and chart recorder used during the tests are illustrated in Figure 2. The coil of wire is

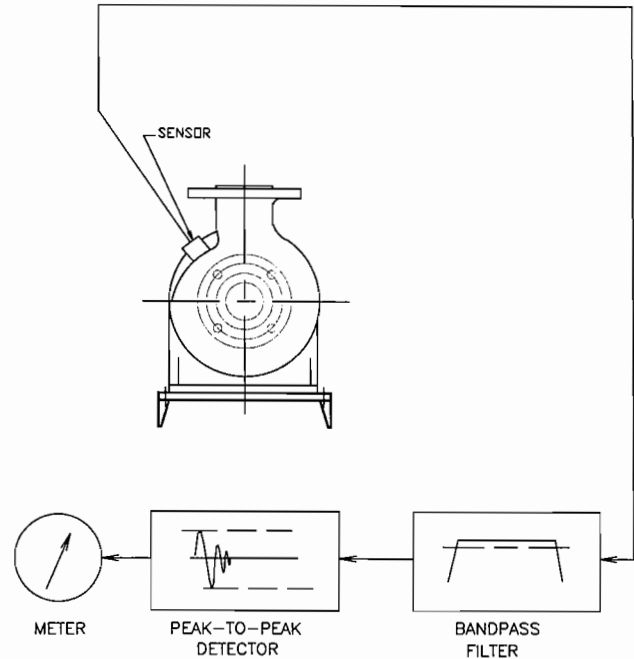

Figure 1. Schematic of Pump and Connection to the Spike Energy Monitor and Processing.

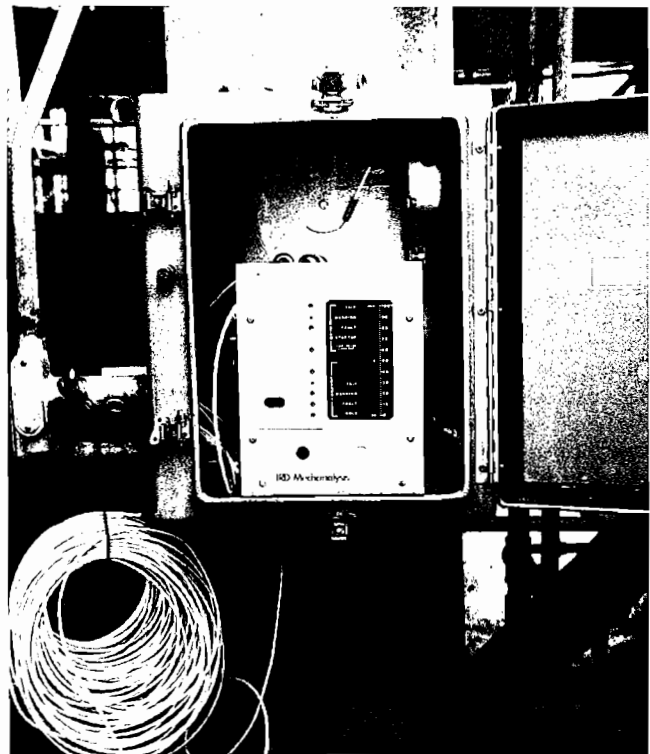

Figure 2. Signal Processor and Chart Recorder used for Testing.

connected to the monitor and was used to sample other pumps not permanently connected to the monitor.

The sensor was put into operation on the first pump in November 1992 and has been operating continuously since. The original test pump was one that had a flow indicator in the discharge line. The flow indication consists of the sum of the traces marked "A" and

“B” on the strip chart shown in Figure 3. There are four traces on the chart but only two apply to the discharge flow of the monitored pump. It provided valuable information about the pump performance at the same time that the sensor signal was changing on the chart. The best interpretation of pump performance during a signal change requires the pump discharge flow in conjunction with the acoustic signal. It is ideal if both are on the same chart. The combination, however, is not required for determining metal-to-metal contact.

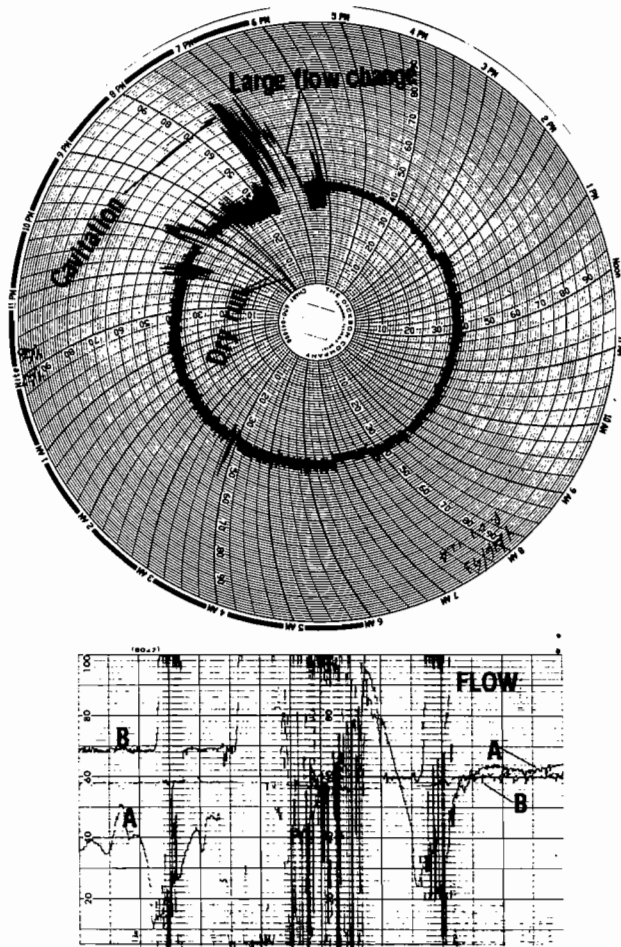
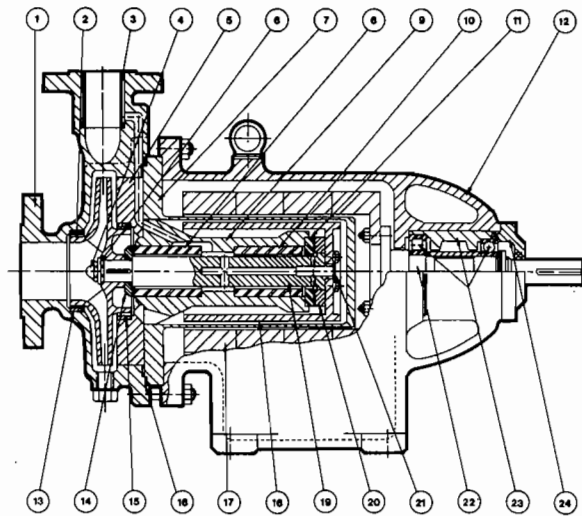

Figure 3. Indications of Cavitation, Occasions of Dry Running, and Large Flow Changes.

The vibration sensors were IRD model 960, with a frequency range of from one to 65 KHz. The processor cards were set for a range of zero to five gSE. The term gSE stands for acceleration units (g's) of spike energy which are dimensionless units. The higher the reading, the louder, or in the case of metal-to-metal contact, the more severe the metal contact. Spike energy is a term sometimes used to describe the high frequency vibration generated when metal rubs against metal. It is called this because of the “spiky” appearance generated on an oscilloscope.

The 960 sensors are connected to an IRD 5806 monitor for signal processing with six channels that are continuously active. The monitor has the ability to set time delays, alerts, and trips. None of these were used during the testing because limits for this new application had not been established. The monitor output is a four to 20 ma (milliamp) signal, which was received by a 24 hr circular chart for recording data during test runs. The chart record-

er was set so that a zero gSE output from the sensor produces a 4.0 ma (milliamp) output from the monitor and was equivalent to zero percent of five gSE on the chart. A five gSE output produces a 20 ma (milliamp) output that is equivalent to 100 percent of five gSE on the chart (full scale) or five gSE. The sensor was mounted to the casing of the initial test pump (Kontra HS2D/1DM). That is a 2 in x 1 1/2 in pump in lethal service with a 15 hp motor operating at 3600 rpm. The “H” range pump is of the eddy current drive type. A cross section is shown in Figure 4 of the pump that was continuously monitored during testing. The test pump, shown in Figure 5, has the sensor mounted on the pump casing at the 11:00 o'clock position, when viewed from the pump suction end. It was mounted by drilling and taping a hole in the casing flange for a 1/4 - 28 stud where the outer magnetic ring housing mounts to the casing. For a canned motor pump, the sensor was mounted at the 11 o'clock position on the casing near the joint where the stator joins the casing. The drilling was between two studs that hold the outer housing and the casing together. The hole is “blind,” so it does not require sealing. The sensor should be installed on a machined flat spot in the flange of the pump with a coupling fluid between the sensor and the casing. The flat spot should be flat within 0.001 in with a surface finish of 125 μin and the coupling fluid is a light coat of silicon grease. The 1/4 in mounting hole should be perpendicular to the flat spot, which ensures the best transfer of signal from the pump casing to the sensor. A mounting detail for the sensor is shown in Figure 6. If the sensor is not installed correctly, the signal will be very weak and there will be no definition or character to the output. This condition can hide pump problems that would otherwise be detected. If the sensor is loose or becomes loose in service, it must be tightened and a thread locking liquid can be used to eliminate a repeat of the problem. It is easy to detect a loose sensor in operation because the signal will be greatly attenuated and the base line will drop substantially from the normal base line for a given pump.



No.	Part	No.	Part	No.	Part	No.	Part
1	Casing	7	Containment Shell	13	Front Neck Ring	19	Shaft
2	Impeller	8	Front Bushing	14	Front Thrust Washer	20	Rear Thrust Washer
3	In-Line Filter (Optional)	9	Bushing Holder	15	Back Neck Ring	21	Torque Ring Tab Washer
4	Impeller Nut	10	Rear Bushing	16	Casing Gasket	22	Drive Shaft
5	Casing Plate	11	Thrust Pad	17	Outer Magnet Ring	23	Bearing Assembly
6	Impeller Lock Washer	12	Housing	18	Torque Ring	24	End Cap

Figure 4. Cross Section of Sealess Pump Continuously Monitored.



Figure 5. Pump with Sensor Mounted for Continuous Monitoring.

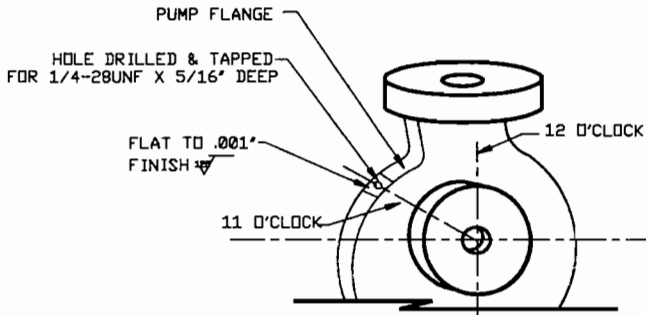

Figure 6. Detail of the Mounting of the Sensor on the Pump Casing.

Testing of the sensor mounting was done to ensure that a sensor was going to give satisfactory information. The sensor mounting test utilizes a piece of aluminum angle marked at one foot and a ball bearing weighing 286g. Impact tests were performed and the results recorded. The weight of the ball is not significant, but once testing begins with a specific ball, it should always be used to ensure consistent input force. This test ensures uniformity of mounting between pumps, and adequate mounting. The angle was placed so the ball would contact the casing about two inches below the mounting of the sensor. The ball was allowed to roll down the aluminum angle and strike the pump casing from a distance of one foot. If the spike was less than 10 on the monitor or chart, the mounting was suspect. The angle guide was aligned so the center of the ball made a straight line from its center to the center of the pump suction, (see Figure 7) The mounting test should be performed on a pump while it is not running, suction and discharge valves closed, and the pump is at its quietest. In Figure 7, two tests are shown. One is an acceptable test result and one an unacceptable test result.

Six pumps were connected to the signal processor; However, only one continuously monitored. Five are magnetically driven and one is a canned motor pump. The pumps are of different sizes

and horsepowers. The magnetically driven pumps are of the eddy current and synchronous drive types. Silicon carbide and carbon bearings are used in these pumps.

RESULTS AND DATA INTERPRETATION

The pump with the most test data had carbon bearings with a hardened steel shaft. It is important to know if the rotor supports are soft, as with carbon or graphite, or hard as with silicon carbide. The interpretation of the data and the analysis response to the data will be affected by that knowledge. For example, if the monitor indicates metal-to-metal contact and the bearing material is silicon carbide running against silicon carbide, it is known that the bearings have already failed and the pump must be stopped immediately.

If the bearings are of a softer material (carbon, graphite, or plastic) there is more time to watch the indications and determine the severity and location of the problem. The detection becomes more predictive and the source of the problem may be identified. The additional time allows a more in depth analysis.

There is a characteristic signature for each pump that is based on the system and pump operation. Experience has indicated that all of our pumps have a base line of between 15 and 25 percent of zero to five gSE, that is 0.75 to 1.25 gSE, when overhauled properly at startup. This base range applies to all of the magnetically driven and canned motor pumps tested. After a base line record for a pump, it is simple to determine operating conditions and the mechanical condition of that pump. For example, Has the freshly started pump been overhauled correctly? Is it running dry? Is it cavitating?

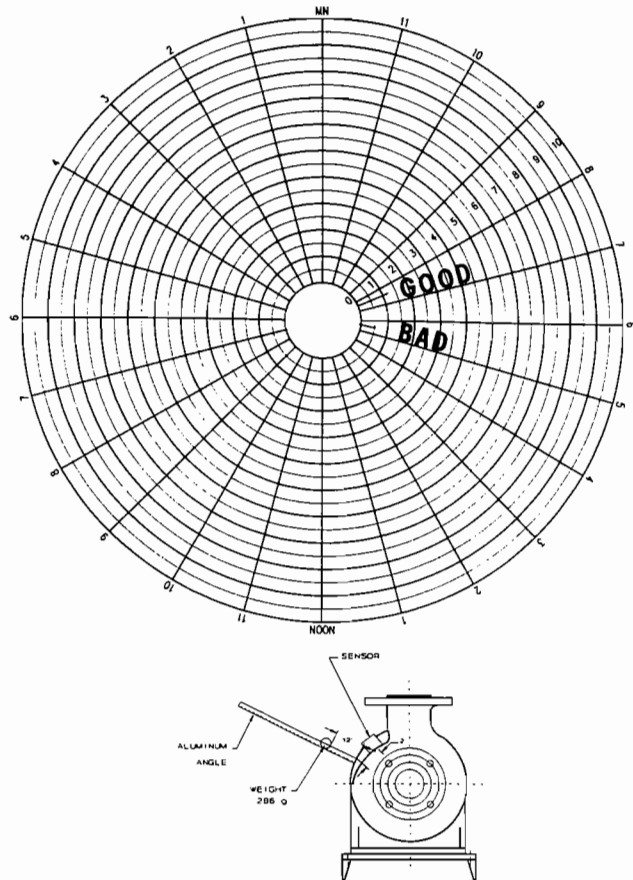

Figure 7. Detail of the Impact Test and the Results to Test Mounting of the Sensor.

There have been 10 instances of instrumented pumps being removed from service for inspection. Three times, the pump was removed from service, because there was a problem in the pumping system, but the monitor detected nothing. When the pump was opened and inspected, no problems could be found. There was some wear on the journal and thrust bearings, but they were still within the manufacturers tolerances, and there was no metal-to-metal contact. The seven times that pumps were inspected after the monitor indicated a problem, a problem was found with each pump. Four times it was excessive thrust and the impeller was touching the pump casing. Twice, the torque ring was touching the containment shell and once the fluid area of the pump was packed with solids.

The first metal-to-metal contact caused large spikes to appear on the chart in a gradual manner (Figure 8). The higher readings which were recorded days later, as shown in Figure 9, were continuous as long as the metal-to-metal contact was taking place. The chart returns to a normal reading for a short time when contact stops because the hydraulics of the pump push the impeller away from the casing. It goes back to the higher reading as contact is reestablished. On the first occasion, this phenomena was observed for about nine days before the pump was removed from service. It was allowed to continue, because the significance of the signature was unknown. The thrust bearing was found to have excessive wear and the results are illustrated in Figure 10. The normal end play on this pump is between 0.030 and 0.070 inch. The thrust on the pump shown in Figure 10 was 0.280 in when checked at tear down. The rotating element of the thrust is normally 0.263 in thick and this one was worn to 0.115 in. There was a loss of 0.148 in of metal from the thrust washer with additional material worn from the stationary carbon. This excessive thrust allowed the impeller to contact the pump casing on its outer diameter. There was no performance loss and had it not been instrumented, the pump would have been allowed to run.

The pump overhaul consisted of replacing the thrust washer, carbon thrust pad, bearings and balancing the impeller. The overhaul cost was minimal as compared to about five to eight times that

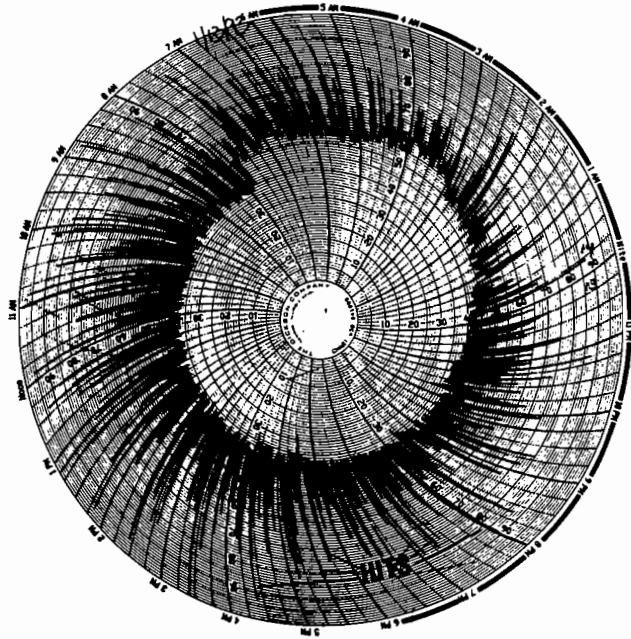

Figure 9. Signature of Metal-to-Metal Contact Between the Pump Casing and the Impeller After Three Days of Continuous Contact.

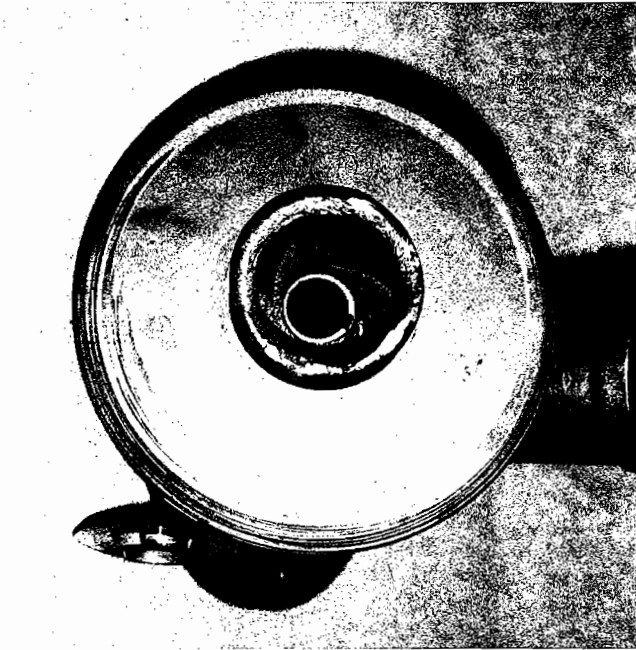

Figure 10. First Failure with Worn Thrust Bearing and Evidence of Impeller Contact.

amount if the pump was allowed to continue until some performance parameter caused it to be removed from service. The savings are influenced by factors such as the pump metallurgy, experience in data analysis, and how long after detecting a problem the pump is allowed to operate. This pump is in lethal service and the potential for a release is always present.

The size of the spikes are proportional to the force with which the metal-to-metal contact is taking place. The larger the spikes, the more force there is in the contact. The period between the large

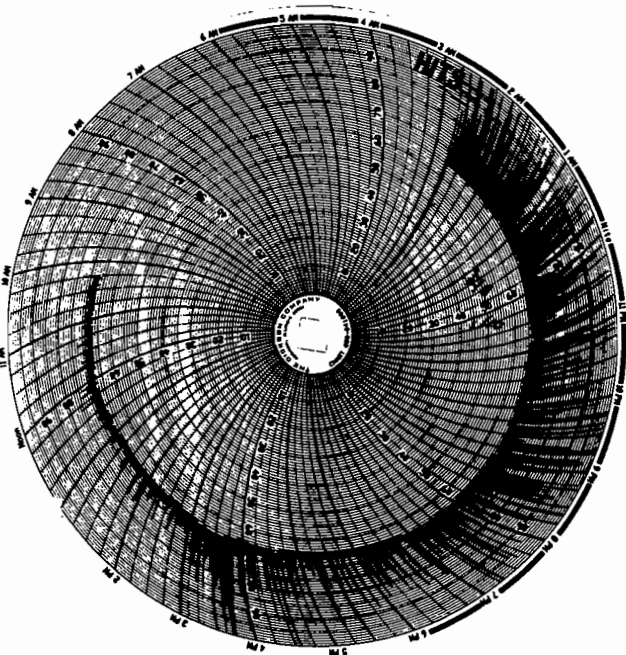

Figure 8. First Metal-to-Metal Contact Detected. Impeller just beginning to contact the pump casing.

spikes is an indication of how badly the bearings are worn. If the thrust has excessive wear, the spikes will be longer and close together (Figure 9). If less wear, the spikes will be shorter and further apart (Figure 11 (a)).

Contact between impeller and pump casing gives a very different signal than a rub in the containment shell. A pump, P-07-12 A, illustrated in Figure 12, experienced impeller to casing contact. The curve marked P-07-12 B in Figure 12, is the startup of the standby pump, after a recent overhaul. The signal was at a high value at startup, compared to the expected 15 to 25 percent on the chart, of five gSE. The signal went off scale and stayed there until the pump was stopped at 8:30 a.m. on March 25. This failure was found to be the containment shell contacting the inner torque ring, because of a stackup of clearance problem in the recently overhauled pump.

Off scale monitor readings detected that the containment shell fluid area, between the rotating and stationary parts, was packed with solids. The pump performance was normal. Had the pump continued to operate, it would have been destroyed. Except for the spike energy monitoring, there was no indication of any problems.

A third failure was captured on charts and is illustrated in the group of Figures 11 (a) to 11(h). These figures depict a sequence of events from the very beginning of metal-to-metal contact, until the pump was removed from service with a thrust failure (impeller to casing contact). At first, the impeller contacts are infrequent. As the thrust bearing continues to wear the interval between contacts is shorter and, hence, the spikes get closer together. The large spikes are a characteristic pattern that occurs when the impeller is hitting the pump casing. The sensor picked up the contact immediately, because it was mounted in close proximity to the contact

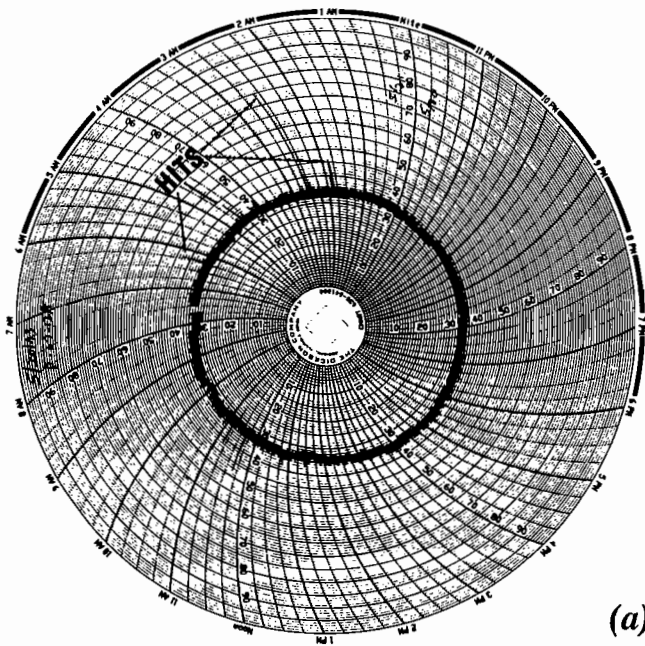

(a)

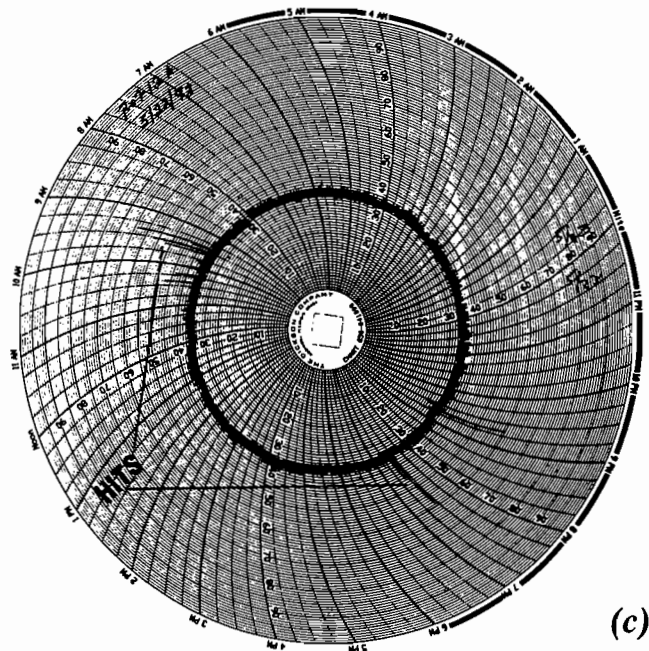

(c)

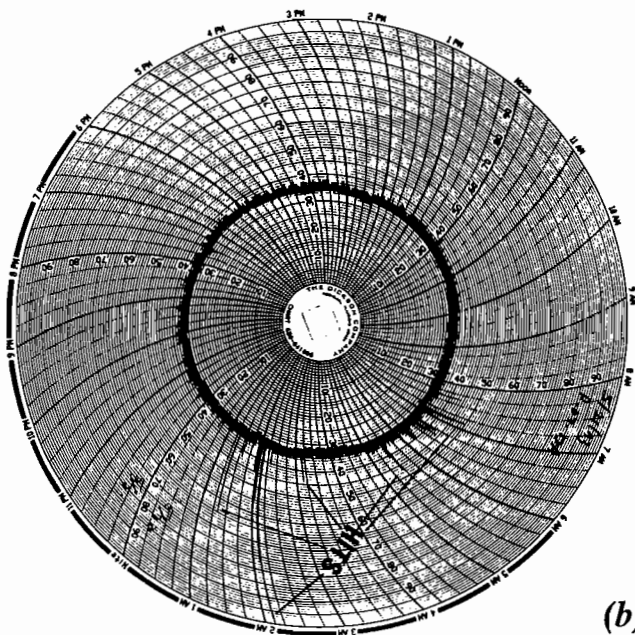

(b)

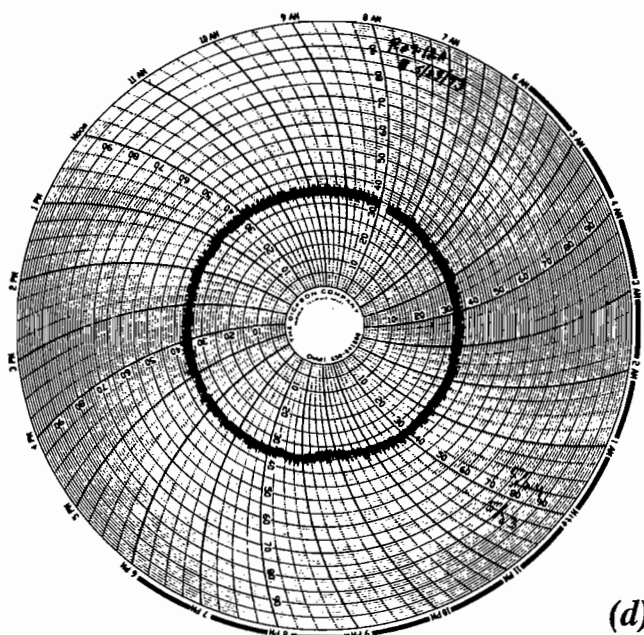

(d)

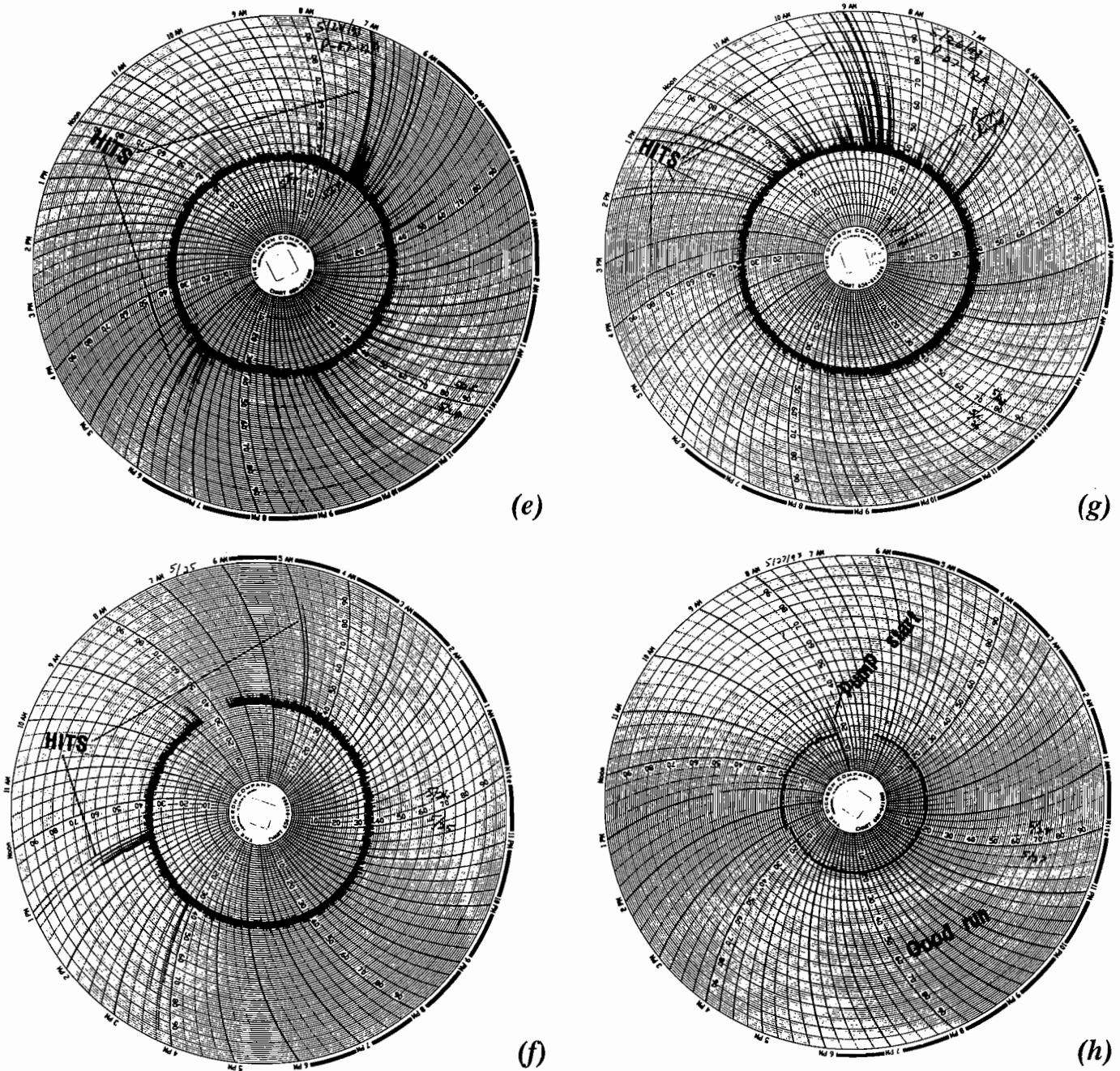

Figure 11(a)-(h). Sequence of Metal-to-Metal Contact as It Progressed to the Removal of the Pump from Service (Thrust Failure).

site. If the pump was internally inspected, as soon as spikes appeared, it may have been difficult to locate the actual contact point.

During the testing, monitoring and analysis to detect dry running, large flow changes, and cavitation in the pump. All of these indications can be seen on Figure 3.

• **DRY RUNNING**—The probe can easily detect when the pump is running dry. It will cause the gSE level to drop to essentially zero. This will continue until the bearings are sufficiently damaged to cause metal-to-metal contact and then spiking will occur. If flow returns and the bearings are not badly damaged the flow will again raise the sensor output level to a normal range.

• **LARGE FLOW CHANGES**—Large flow changes will cause the signal amplitude to change in response to the change in flow. The direction of the change is not always predictable. For example, a large flow increase may cause the signal to go up and sometimes to go down. What is predictable is that large flow changes are detectable. This information can be used as a problem identification tool in troubleshooting pump and system problems.

• **CAVITATION**—Severe cavitation can be detected with the sensor and is also illustrated in the figure. It usually appears as wide lines. The wider the lines, the more severe the cavitation in the pump. Mild recirculation in the pump casing is a narrower “wide” line than cavitation.

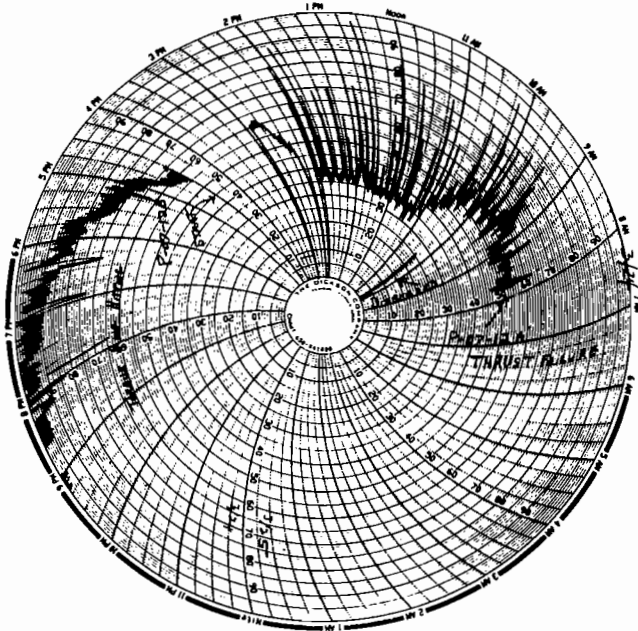

Figure 12. Impeller Contacting Pump Casing Marked P-07-12A and Start of Spare Pump with Containment Shell Rubbing Marked P-07-12B.

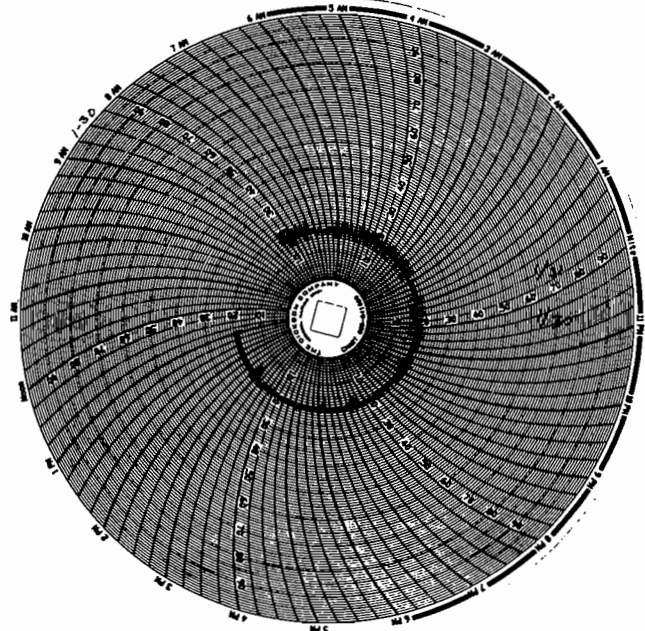

Figure 13. Signal Change After the Change to the New Control System.

During the course of testing, the process control system in the plant was changed to a newer control system. The charts changed dramatically after the change in systems. The pattern after the change to the new control system is represented in Figure 13, and the signal in Figure 11 (h) is shown before the change in systems and after the adjustments. The column that was using the output from this pump became hard to control. There were numerous upsets in the process after the change in the control system. As can be seen from Figure 13 the signal changes were sharp and dramatic. It was suggested to try tuning the control valves in the new system to smooth the flow based on the changes detected with the pump spike energy sensor. The control valves on this pumping system were tuned and the signal patterns returned to normal. The problems with the column disappeared and the plant returned to normal operation as before the control system change.

The spike energy monitor is predictive. For example, if the data is being charted and there are indications of the pump running dry or cavitating, it is a good assumption that metal-to-metal contact will occur soon. This is particularly true of a pump using carbon or graphite bearings. If the pump is using two hard surfaces for bearing materials, they are not as forgiving as carbon and, therefore, the predictive feature of the acoustic monitoring is not as beneficial. Should the pump run dry, with these harder materials, the bearings will shatter and be indicated on the monitor because of the resulting metal-to-metal contact. The monitor will detect the failure of the bearings as soon as it occurs. Other methods of monitoring the internal rotor condition will not react as quickly as this method, and the damage will be more extensive.

If the outer magnetic ring touched the containment shell because of a failure in the support ring bearings of the outer magnetic ring, the contact would certainly be detected. Some magnetically driven pumps use a "rub" strip to catch the outer magnetic ring when the bearings that support it begin to fail. The spike energy sensor would indicate this as metal-to-metal contact. Problems will be indicated by the monitor, but the source of each problem will not always be evident.

Limited testing has indicated that this monitoring method does apply to all types of sealless pumps as long as "good condition" means no metal-to-metal contact.

General Indications and Their Interpretation:

- **ZERO gSE**—If the monitor is reading zero gSE it is an indication that the pump is not running, the probe is not connected, or there is no liquid being pumped. Every running pump generates some noise when it is running and pumping.
- **OFF SCALE**—When the reading is off scale, it is an indication of heavy metal-to-metal contact, extreme cavitation, or the fluid space between the rotor and the containment shell is packed with solids.

If the signal is very high immediately at startup, the pump may have a "stack" of tolerance problems from the parts used in the overhaul that are allowing metal-to-metal contact immediately at startup. This is very difficult to detect in the shop, because after the pump is assembled, the clearances can not be measured. The inside and outside diameters can be checked when the pump is open but their concentricity is difficult to measure because the pump must be assembled to check it and when assembled, it can not be measured.

- **LOW READING**—but not zero, in a running pump, may indicate that the probe is not properly attached to the pump casing. Look at the baseline signature taken when the pump was started and compare it to the present signature. If it is low by comparison the sensor is probably loose. As a final check, try tightening the sensor with a wrench.

If a chart is connected to the monitor output additional information is available. Its interpretation is listed below:

- **WIDENING PATTERN**—indicates internal recirculation in the pump or mild cavitation. (Figure 3)

• **LARGE CHANGE/LONG TIME**—change in the amplitude of the signal on the chart over time such as ten to fifteen minutes, will indicate a large change in the flow through the pump. It can not be said, however, that an increase in flow will always give an increase in spike energy level. The condition of the pump and other factors make the interpretation more complicated than that (Figure 3).

• **LARGE CHANGE/SHORT TIME**—change in the amplitude of the signal on the chart over a short period indicates metal-to-metal contact caused by the thrust bearing wearing excessively allowing the impeller to contact the pump casing. The signature generated by this type of contact is illustrated in Figure 9.

• **NARROW LOW SIGNAL**—a correctly installed pump should not have metal-to-metal contact. The readings, from experience, are in the 15 to 25 percent of five gSE range on the monitor for a normally operating pump. This is true for both canned motor pumps and magnetically driven pumps and is illustrated in Figure 11(h).

CONCLUSION

Using spike energy for monitoring the internal rotor of sealess pumps for metal-to-metal contact will reduce the cost of pump overhauls substantially, especially on pumps with soft bearings. Based on past testing, if the overhaul cost of a pump is equal to "X" when it is protected by the spike energy monitoring system, the overhaul cost without the use of monitoring will be "5X" to "8X." A catastrophic failure will cost "15X." These savings do not include the elimination of spills, releases, or the fines that may be associated with them. A list is presented in Table 1 of overhaul

costs, based on protected failures and unprotected failures of a sealess magnetically driven pump with soft bearings. Canned motor pumps would be similar but not identical. A major failure of this type of pump would require rewinding if the containment were breached.

The spike energy monitor will reliably detect dry running of the pump by indicating a loss of signal when fluid is not being pumped. If the result of the dry run is metal-to-metal contact, the sensor will detect that as well.

Experience has shown that metal-to-metal contact is easy to detect with spike energy. If the pump is removed from service when metal-to-metal contact is indicated, there will be no breach of the liquid containing parts and the damage to the pump components will be minimal. An additional benefit is that overhauls can be checked in the shop or at the initial start of the pump using this technology.

ACKNOWLEDGEMENTS

The author would like to thank Olin chemicals for allowing him to write and present this paper. Also for their help and enthusiasm during the testing of the equipment. He would like to thank IRD and their Houston office for help, support, and the use of equipment for the experiment and Kontro and HMD for their help by providing information and independent verification of this concept in their facilities in England.

Table 1. Cost Comparison for Protected and Unprotected Pumps Using Carbon Bearings.

O.H. + SPIKE	O.H.	MAX. O.H.
BUSHINGS	BUSHINGS	BUSHINGS
THRUST PAD	THRUST PAD	THRUST PAD
BK. THRUST WASHER	FR. THRUST WASHER	FR. THRUST WASHER
	FR. IMP WEAR RING	FR. IMP WEAR RING
	BK. IMP WEAR RING	BK. IMP WEAR RING
	IMPELLER REPAIR	IMPELLER REPAIR
	SHAFT	SHAFT
	1/4 TORQUE RING	TORQUE RING
	1/10 CASING	CASING
	1/5 CONT. SHELL	CONT. SHELL
TOTAL	X	5X TO 8X
		15X