

HYDRAULICALLY RERATING CENTRIFUGAL PUMPS TO IMPROVE RELIABILITY

by

Robert X. Perez

Senior Reliability Engineer

CITGO Refining and Chemicals, L.P.

Corpus Christi, Texas

and

Claude Knight, Jr.

Regional Sales Manager

Flowserve Corporation

Houston, Texas



Robert X. Perez is a Senior Reliability Engineer for the CITGO Corpus Christi Refinery, in Corpus Christi, Texas. His primary duties include troubleshooting rotating equipment problems, leading root cause failure analysis teams, and serving as the plant consultant in the areas of vibration analysis and rotordynamics. He has previously written and been a coauthor on several papers in the field of machinery vibration.

Mr. Perez is a registered Professional Engineer in the State of Texas and a member of ASME and the Vibration Institute. He received his B.S. degree (Mechanical Engineering) from Texas A&M University, and an M.S. degree (Mechanical Engineering) from the University of Texas.



Claude "Bud" Knight, Jr., is currently the Regional Sales Manager for Flowserve Corporation (a merger of the former BW/IP International, Inc., and Durco International companies), located in Houston, Texas. His current responsibilities include the growth and development of the Service and Repair Division, concentrating primarily on centrifugal pumps with a focus on engineered upgrades, hydraulic rerates, mechanical retrofits, and enhanced

reliability remanufactures.

Mr. Knight's previous 13 years in the Pump Division included five years as a Repair Engineer and six years as a Sales Engineer. He graduated from Texas A&M University with a B.S. degree in Engineering (1982), with an emphasis in Metallurgy.

ABSTRACT

The authors present two case studies where improperly applied hydraulics resulted in poor mechanical reliability, due to chronic flow instability problems. A successful hydraulic rerate of these pumps, which required minimal modifications to their original pump casings and no modifications to the piping, drivers, or baseplates, dramatically improved their reliability and reduced annual repair costs. The first case study describes the rerate of a $4 \times 6 \times 13$, 3560 rpm, 300 hp, single suction overhung pump and its spare, which were averaging between seven and 12 failures per

year from 1990 to 1995. The second case study involves the rerate of a $12 \times 14 \times 23$, 1780 rpm, 600 hp, double suction, between bearings pump and its spare, which were experiencing three to five failures per year. Both rerates involved selecting an impeller pattern with a best efficiency point closer to actual operating conditions and an acceptable suction specific speed ($N_{ss} < 11,000$), and then modifying the pump casing to obtain the proper volute throat areas for the desired performance. The pumps in both case studies realized marked improvements in reliability as a result of the hydraulic rerates. The authors will take the readers through the rerate process, illustrating the key steps involved, and explain which types of problematic pumps qualify for this conversion. They will also clearly explain the hydraulic principles employed to give the readers insight into the design process. Finally, the authors will explain the economic benefits that can be derived from a hydraulic rerate and how this type of work can be economically justified.

INTRODUCTION

Centrifugal pumps are the work horses of the petrochemical industries. They are often called upon to pump corrosive and flammable fluids at high temperature and at high energy levels. The trend to push them to higher speeds and horsepower ratings, while demanding higher levels of reliability, presents a major challenge to machinery engineers. Today, machinery engineers have three basic goals, which are to:

- Maximize pump reliability,
- Minimize overall pump repair costs, and
- Minimize pump risk levels.

For spared pumps, maximizing a pump's mean time between failure (MTBF) is usually the most effective means of accomplishing all these goals. By reviewing the most common modes of failure and determining the root causes of the failures, one can be successful in extending pump MTBF to two to three years between failures. Whenever the MTBF of a pump falls below one year, and certainly when it falls below six months, a detailed investigation into the root cause of controlling failure mechanisms is well justified. These investigations should include surveying past repair records, close examination of all damaged parts, dimensional inspection of critical fits, and even hydraulic surveys.

Common root causes of failures are often mechanical in nature, such as seal flush problems, misalignment, poor bearing fits, imbalance, etc., but can also be hydraulic in nature. Hallam (1982) found that pumps with suction specific speeds greater than 11,000 have significantly higher failure rates than those below 11,000.

Pumps with suction specific speeds higher than 11,000 are prone to hydraulic problems commonly manifested as mechanical failures. Machinery engineers are skillful at improving the MTBF of their pumps with mechanical improvements, such as bearing and mechanical seal upgrades. However, hydraulic improvements aimed at improving mechanical reliability are not commonly employed for a number of reasons:

- Hydraulic instabilities are not always obvious to users.
- Users may not be willing to replace problematic pumps with those possessing improved hydraulics, due to unfavorable economics.
- In some cases, users may not know how to improve pump hydraulics.

HYDRAULIC MALADIES

Centrifugal pumps like to operate at their best efficiency point (BEP), where they perform at their highest efficiency and lowest vibration and noise levels. Pumps can also operate safely over a flow range, but there are risks associated with off-design operation. Operation significantly below the best efficiency point causes pressure pulsations and unfavorable flow patterns that can result in:

- Impeller and casing erosion,
- Significant shaft deflection and associated stresses,
- Impeller failure,
- High rates of radial and thrust bearing failures, and
- High rates of seal failures (Hallam, 1982, and Nelson, 1984).

It is prudent for users to determine the minimum continuous stable flow (MCSF) for their pumps before the pump is placed in operation, so that proper safeguards are put in place to preclude unsafe operation.

Fraser (1981) and others have investigated the nature of internal recirculation that occurs at off-design conditions. These flow reversals, which can occur at the impeller eye or at the impeller discharge tips (Figure 1), can generate damaging pressure pulsations (Florjancic, 1993) that can limit the minimum safe flow of pump operation. Figure 2 shows how pressure pulsations related to internal recirculation are generated at low flows (Fraser, 1981). Incipient internal recirculation is the point where the centrifugal pressure field exceeds the dynamic head gradient. Comparing a high N_{ss} impeller with a low N_{ss} impeller, the reader will discover the high N_{ss} impeller has a larger impeller eye and, therefore, a correspondingly lower inlet fluid velocity than that of a lower N_{ss} impeller. At lower flows and related lower inlet fluid velocities, the dynamic head falls below the centrifugal pressure, resulting in suction recirculation. This explains why impellers with low inlet velocities and high suction specific speeds are more susceptible to internal recirculation. In high energy pumps (> 250 hp/stage), internal recirculation can impart damaging levels of fluid energy in the impeller, shaft, bearings, and casing.

The factors required to determine the MCSF for a pump are the pump's:

- BEP flow (use $\frac{1}{2}$ this flow for double suction impellers).
- The suction specific speed, N_{ss} , for the impeller.
- The pump type, such as single stage, double suction, or multistage.
- Pump size.
- Some methods also require $NPSH_A$, $NPSH_R$, and fluid type. Users must be more cautious with water and other single-component fluids with a specific boiling point, but can be less conservative with multicomponent fluids, such as kerosene, crude oil, etc., that have a boiling point range.
- Mechanical design (i.e., L/D ratio, overhung versus between bearings design, etc.).

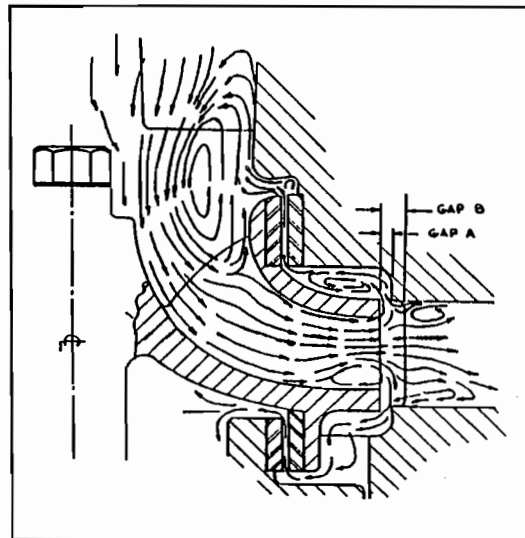

Figure 1. Secondary Flow Pattern in and Around a Pump Impeller at Off-Design Conditions.

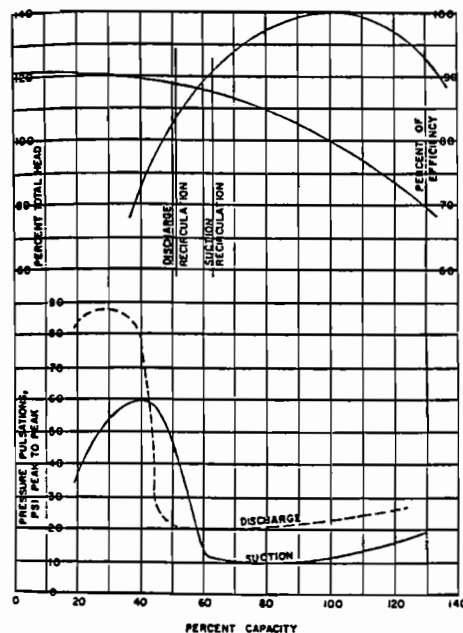

Figure 2. The Effect of Off-Design Flow on Pressure Pulsation Levels.

There are numerous methods available to determine the MCSF, such as those proposed by Heald (1996), Fraser (1981), and others. One common conclusion that can be drawn from these methods is that an impeller's N_{ss} has a significant impact on the useful flow range of the pump. The higher the impeller's N_{ss} , the narrower its operating range. Figure 3 (Lobanoff and Ross, 1992) clearly illustrates the effect of N_{ss} on the width of the operating flow window. For example, a pump with an N_{ss} of 8,000 can be operated in a stable manner from about 60 percent to 120 percent of its BEP, while a pump with an N_{ss} of 13,000 can only be operated in a stable manner from about 80 percent to 110 percent of BEP. (Keep in mind, Figure 3 is only presented as a general example and cannot be applied widely.) Hallam (1982) has suggested a practical upper limit of 11,000 for N_{ss} when selecting new general duty process pumps. Dufour and Nelson (1993) recommend boiler feed and condensate pumps and general hydrocarbon pumps should have N_{ss} values in the 8,500 to 11,000 range.

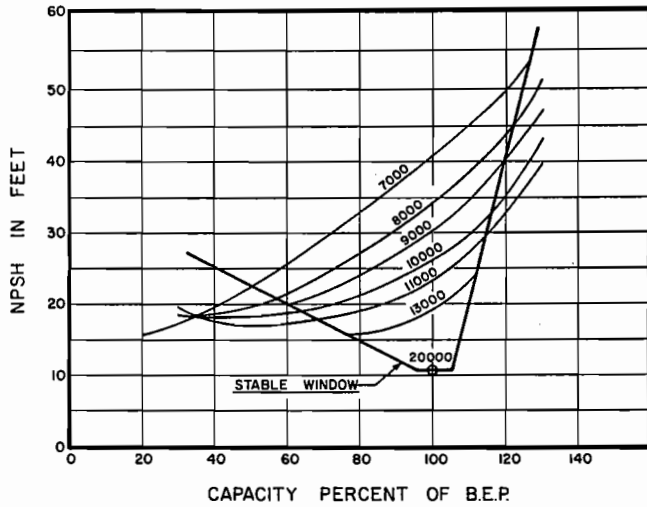

Figure 3. Stable Operating Window Versus Suction Specific Speed.

The reason there are numerous methods of determining the safe minimum continuous flow for pumps present in the literature is that there are no universally accepted guidelines for dynamic force limits. Internal recirculation alone does not lead to mechanical failures. It is the unstable flow field that generates pressure pulsations and the resulting dynamic forces on pump elements. Fraser's (1981) minimum flow guidelines are based on the onset of internal recirculation, while Heald's (1996) and the API 610 guidelines are based on the vibration levels associated with low flow operation. The problem with using vibration alone as a criterion for minimum flow determination is that pump bearing housing stiffnesses vary widely. Vibration levels may not truly reflect the magnitude of the dynamic forces acting on them. Dufour and Nelson (1993) have presented simple, conservative minimum flow guidelines based on the impeller types and N_{ss} values. For example, they recommend an absolute minimum flow of 50 percent of BEP for all pump types. They go on to recommend that double suction pumps should be operated above 60 percent to 70 percent of their BEP at all times. As is usually the case, the onus for the determination of the actual minimum flow guidelines falls on the user. As suggested by Fraser (1981), another method of determining the initial point of internal recirculation is by measuring and plotting pressure pulsations as a function of flow as seen in Figure 2. The points where suction recirculation and discharge recirculation occur can clearly be seen in the pressure pulsation versus flow plot. Users of pumps must use a mixture of recommendations presented in the literature and good judgment based on their experience. In services representing high risk levels, conservatism is warranted, and for common low-risk services, liberal guidelines may be used.

THE RERATE SOLUTION

It is not uncommon that a process engineer calculates the required pumping flow for a new pump application and adds 10 percent to that value for uncertainty. Then the project engineer will usually add another 10 percent for good measure. As an example, let us say the process engineer has determined he needs 1000 gpm of flow, so he asks for 1100 gpm. The project engineer asks for vendors to quote a pump rated at 1210 gpm. The pump vendor receiving the purchase order delivers a pump with an N_{ss} of 13,000 and BEP of 1500 gpm. On the surface, this looks like a good fit ($1210/1500 = 81$ percent of BEP), but if you consider that the pump will actually be operated at 1000 gpm, you can see the pump will be operated at 67 percent of its best efficiency point. Revisiting Figure 3, it is clear a pump with an $N_{ss} = 13,000$ will be operating outside its stable operating region. Users should expect that this pump will exhibit higher than normal mechanical failures during its life, unless the pump hydraulics are improved.

There are ways to avoid chronic hydraulic instability problems. The following methods can be used to improve stability and hence improve pump reliability:

- Install a minimum flow spill-back line. In this scheme, a total pump flowmeter is installed upstream of a spill-back line. Whenever the total pump flow falls below the minimum flow for the pump, the control valve in the spill-back lines opens and allows the total pump flow to be maintained at a safe level. This method has been successfully used by one of the authors (Perez) to improve flow stability. The disadvantage of this option is that it wastes horsepower when the pump is operated below its minimal flow.
- Replace the pump with one better suited to the actual flow requirements. This is expensive and usually requires piping and foundation changes.
- Rerate the problem pump with a better fitted impeller, using the existing pump casing, baseplate, and foundation. This option typically costs a fraction of the cost of the second option.

Of the options mentioned above, the rerate option is usually the most appealing, because it is cheaper than buying a new pump, it does not require an expensive spill-back line, and it does not waste horsepower at flows below the original minimum flow point. Performing a rerate requires that an impeller capable of the desired performance and with an acceptable N_{ss} be available. In addition, the suction system must have excess $NPSH_A$ to allow the new, lower-flow impeller to be used. If you remember, it was stated that internal recirculation occurs when the centrifugal pressure field exceeds the dynamic (or velocity) head gradient. Suction recirculation, for example, occurs because the inlet velocity falls to critical levels at lower flows. So, in general, to improve hydraulic stability, inlet and outlet impeller fluid velocities must be increased. At the impeller eye, increasing the average fluid velocity means decreasing the eye area and increasing the $NPSH_R$. Figures 4 and 5 show two different plots of normalized $NPSH_R$ versus flow. Figure 4 shows a proposed impeller with excess $NPSH$ margin ($NPSH_A - NPSH_R$) and Figure 5 shows a proposed impeller with little or no $NPSH$ margin. The impeller depicted in Figure 4 could be replaced with a better fitting impeller because of the excess suction head margin available, but the impeller depicted in Figure 5 could not be rerated.

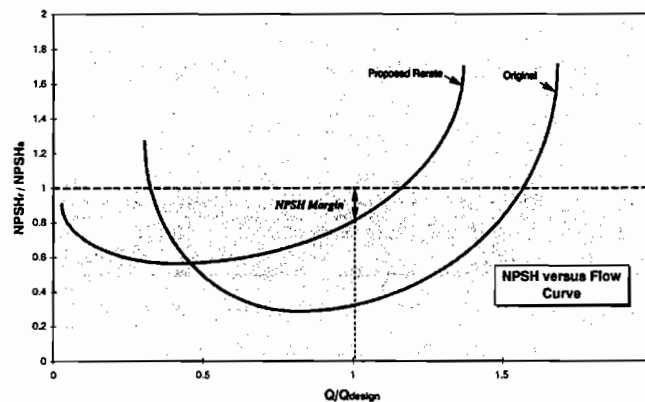

Figure 4. Example of a Viable Hydraulic Rerate.

Figure 6 shows a cross section of a typical pump rerate. It can be seen that the original pump case, impeller shaft, and mechanical seal are unaffected by the rerate. The basic idea is to fit an impeller with a lower flow rating inside an oversized pump casing. To accommodate a smaller impeller, oversized case wear rings are used. In addition to these changes, the volute throat area(s) have to be matched to the new impeller. This is done by cutting out the original volute lips and welding in custom designed volute lips. This simple, straightforward design provides a cost-effective solution for chronic hydraulic instabilities.

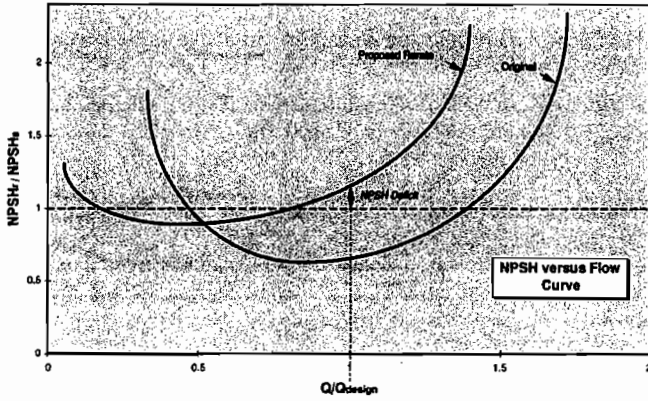

Figure 5. Example of a Nonviable Hydraulic Rerate.

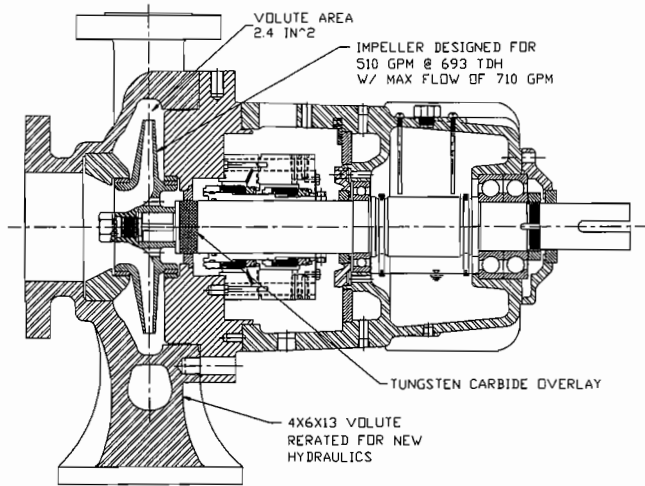

Figure 6. Cross Section of a Typical Hydraulic Rerate with Power End Upgrade.

RERATE CASE STUDY 1—
300 HP LEAN AMINE PUMPS

Two (main and spare) 4 × 6 × 13 single stage, overhung centrifugal process pumps coupled to 300 hp, 3570 rpm electric motors were installed in 1976. Table 1 shows the combined failure history of both pumps.

Table 1. Combined Failure History of Both Pumps (Case Study #1).

Year	Number of Failures
1990	7
1991	7
1992	7
1993	6
1994	7
1995	13

This history equates to an average of 7.8 failures per year and an average MTBF of .13 years or 47 days!! Shaft and impeller bolt failures constituted a high percentage of the historical failures. The shaft failures were determined to be related to fatigue. Several years ago, shaft metallurgy was upgraded to improve endurance limits in an effort to preclude fatigue related failures. This improvement had little or no effect on the MTBF. After an all-time high of 13 failures in 1995, it was decided to revisit these

problematic pumps and conduct a detailed investigation into the root cause of the shaft failures.

The frequent failures of the shafts due to fatigue, noisy operation of the pumps, and broad frequency content in the recorded vibration spectra all seemed to point to a hydraulic instability problem. To confirm this, the N_{ss} for the pumps was calculated. It was a surprise to discover the N_{ss} was 16,600, which is well above the recommended limit of 11,000 for general duty process pumps. Referring to Fraser's (1981) guidelines, the reader can see that single suction impellers (corresponds to line "ss" in Figure 7) with N_{ss} values above 15,000 have no turndown capabilities. This means these pumps must be operated at their BEP to avoid internal recirculation. To make matters worse, it was also discovered the pumps were normally operated at 31 to 36 percent of their BEP. It is obvious these pumps had no chance to operate reliably. (Note: While the original pump curves contained no caveat concerning operation well below the best efficiency point, current sales performance curves from the original equipment manufacturer now recommend a minimum flow of 1000 gpm, or about 71 percent of the BEP.)

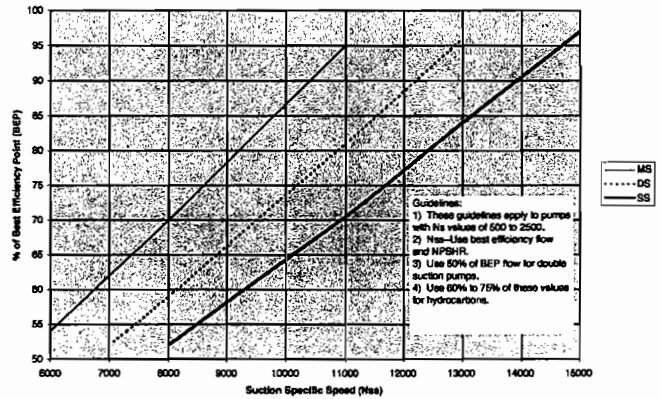

Figure 7. Minimum Flow Guidelines for Centrifugal Pumps ($N_s = 500$ to 2500).

To consider a hydraulic rerate, an available impeller pattern capable of handling the head/flow requirements and additional $NPSH_A$ to handle the smaller impeller eye related to the smaller flow rating was required. It was fortunate that both conditions were satisfied. Table 2 lists the original and proposed impeller characteristics.

Table 2. The Original and Proposed Impeller Characteristics (Case Study #1).

	Original Design	Proposed Design
Design flow (rated)	440 - 710 gpm	440 - 710 gpm
Design temperature	170°F	170°F
Pump/Impeller size	4" × 6" × 13"	3" × 4" × 13"
BEP flow	1400 gpm	775 gpm
Volute throat area	5.0 in ²	2.4 in ²
Q_d/Q_{bep}	31% - 51%	57% - 92%
N_{ss}	16,650	9,636
Q_{min} (est)	1126 gpm	320 gpm
Efficiency	55% @ 510 gpm	67% @ 510 gpm
BHP	153.4 bhp	130.2 bhp
$NPSH_R$	6.2 ft @ 510 gpm	12 ft @ 510 gpm

Figure 8 shows the original and proposed performance curves, which illustrate the improvement in hydraulic fit. The BEP of the proposed impeller is closer to the actual flow required by the process. The combination of improved hydraulic fit and lower N_{ss} value made the proposal attractive. (APPENDIX A describes the thought processes and analytical methods, typically used in a hydraulic rerate, for the selection of a suitable impeller and volute throat area.)

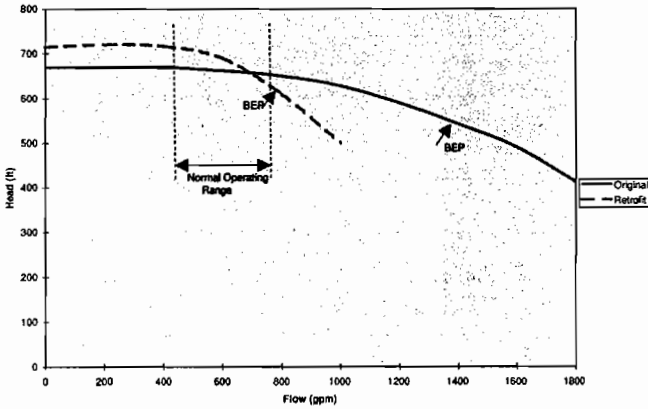

Figure 8. Comparison of the Original and Proposed Performance Curves (Case Study #1).

Preliminary economics were based on the assumption that the failure rate and annual repair costs of these pumps would drop 75 percent. The savings of approximately 23 hp, due to improved efficiency, were also included in the project economics. An analysis of the rerate costs and associated benefits revealed that an internal rate of return (IRR) of about 29 percent could be realized. Because of the favorable tangible benefits and intangible benefits, such as fewer frequent operational interruptions, the rerate project was approved.

HYDRAULIC AND MECHANICAL DESIGN DETAILS

A successful hydraulic rerate begins with the selection of an impeller design that best satisfies the flow, differential pressure, and NPSH_A requirements for the application. Referring to Figure 9, the reader can easily distinguish the significant differences in the existing and new impeller, noting especially the impeller eyes. Due to the reduction requirement of flow, the impeller eye area decreased from 22 in² to 13.2 in², thereby reducing the suction specific speed value and increasing the reliable operating range of the pump. This new and smaller optimal impeller design meant that the impeller's physical geometry no longer fit the existing volute, so changes had to be made. Due to the need to maintain the impeller to volute centerline, the suction and discharge wear ring journals in the original design became sufficiently short of achieving the desired 80 percent wear ring overlap. Therefore, the case and cover wear ring areas were redesigned to move toward the volute centerline, while maintaining their original fits (Figure 6). Additionally, the impeller width and bore lengths were sufficiently shorter than the original impeller. To maintain the centerline arrangement, the shaft locating shoulder had to be modified, along with the impeller journal diameter, in order to fit the smaller impeller bore.

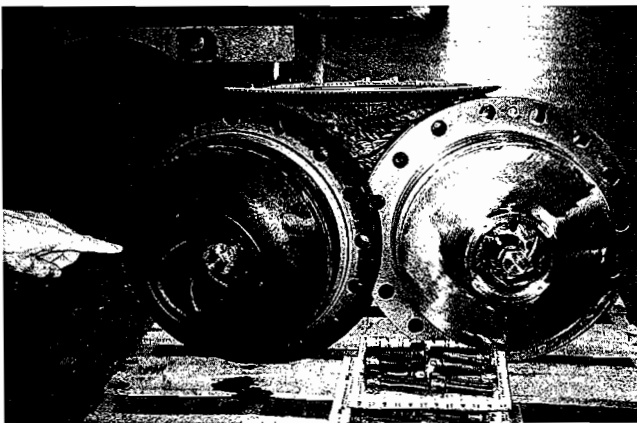

Figure 9. Side by Side Comparison of Original and Rerated Impellers (Case Study #1).

An important aspect of this rerate involved matching the volute area to the new impeller hydraulics, meaning that the volute throat would have to be minimized from its original cast area of 5.0 in², to that of 2.4 in². (Refer to APPENDIX A for additional information on how the volute throat area was determined.) The general idea is to remove as much existing volute cutwater as practical, so that the progression of fluid velocity is consistent from the initial cutwater (Figure 10), to the point of full pressure development prior to exiting the nozzle at full rated capacity. To enhance the more uniform velocity reduction, the manufacturer selected a point at which the least amount of disturbance to velocity would occur and removed the "long" volute up to this point. Correspondingly, the newly engineered volute was inserted and welded into place following ASME Section IX weld procedures, necessitating that specific preheat, interpass, and post heat specifications would be followed (Figure 11). The new volute insert (Figure 12) was manufactured from mill certified material matching the original cast material, and was machined to provide full weld penetration from the front (top) side on all three edges. While the "B" gap is a primary factor in creating optimum efficiencies, the primary goal of the rerate was to maintain the volute area required for the actual pumping conditions. This resulted in a "B" gap of 14 percent, essentially due to the impeller's final trim diameter. The shorter of the two volute cutwater's was also cutback, as previously described, to establish a premier velocity reduction surface for the new volute, and to ensure an integral foundation for the root of the new volute lip. The interfaces between the cast volute wall and the manufactured volute tongue are not in machinable locations, therefore much grinding was required by an experienced mechanic to remove weldments that did not create uniformity, and to alert the welder for additional filler metal when location templates did not match. The final volute lip ends were located exactly 180 degrees apart from each other to further promote radially hydraulic balance (Figure 11).

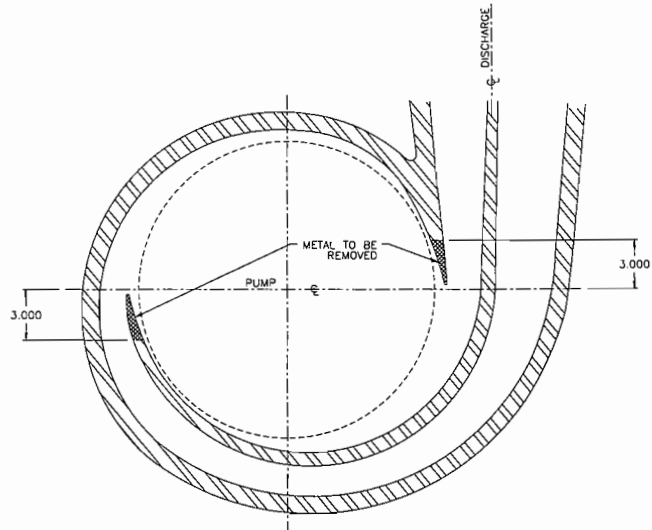

Figure 10. Typical Volute Tongue Removal Detail.

As the original bearing bracket and stuffing box arrangement was manufactured to an earlier edition of API (believed to be the Fifth Edition), an upgrade to Seventh Edition was provided in addition to the hydraulic rerate. Essentially, the existing cast iron bearing housing was replaced with a cast steel bearing housing. The stuffing box could then incorporate a standard sized dual seal arrangement and the L³/D⁴ of the rotor improved from 89 to 24. Most importantly, the rotor ratio improved primarily by the enlargement of the shaft diameter at the shaft sleeve area through the stuffing box, thereby minimizing the deflection imposed by the cantilever effect and the subsequent radial forces imposed by the

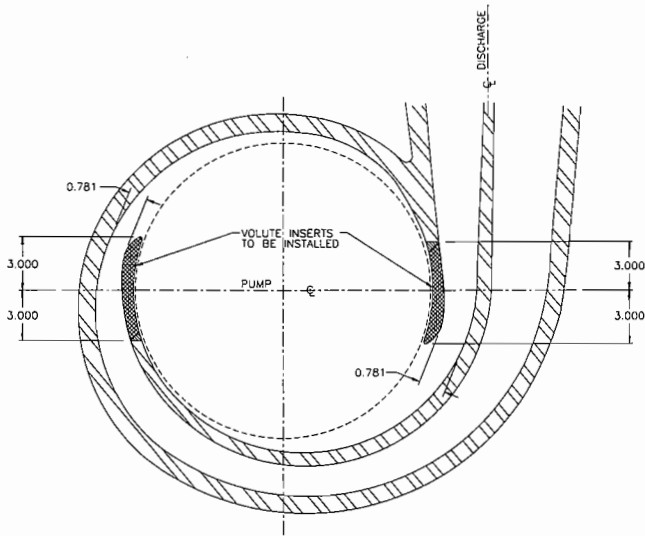

Figure 11. Typical Detail of Modified Volute Tongue Installation.

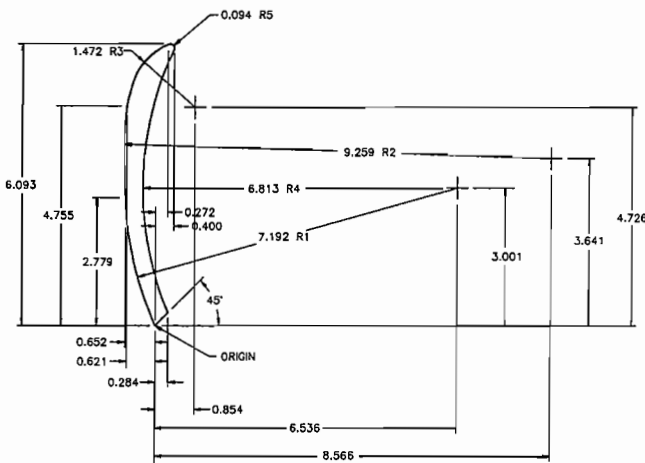

Figure 12. Typical Detail of Manufactured Volute Tongue.

impeller. (Note: The original shaft diameter was 2.437 in, while the new shaft diameter increased to 2.937 in.) This minimization of radial movement also lessens the misalignment of the rotating seal face to the stationary face, improving the seal effectiveness and contributing to seal life. As a matter of convenience, the thrust bearings were also upgraded to that of 7314 duplex 40/15 degrees back-to-back bearings and, additionally, magnetic bearing isolators were installed for additional oil preservation and protection. To facilitate the new bearing bracket and stuffing box components, a new backhead (cover) was engineered. This meant that the same volute bolt pattern and bolting circle were copied, and the gasket shoulder register was designed to facilitate the necessary crush on the flexitallic gasket. Since a new shaft was manufactured to fit the bore of the impeller, along with axially locating the centerline of the discharge vanes, the journal of the shaft that coincided with the throat bushing area was overlaid with a denser and harder layer of tungsten carbide for wearing protection. Following standard procedures, the impeller was ground, polished, and dynamically balanced. The bearing housing interior was glyptol painted and assembled with the bearing isolators.

RESULTS OF THE RETROFIT

Once the assembly of the redesigned pump was complete, it was necessary to performance test the unit to ensure the rated capacity

at differential pressure values would be met with calibrated gauging, driver, and instrumentation. By reviewing Figure 13, it can be seen that at 3570 rpm, the rated flowrate and differential pressure were met, with a corresponding vibration level of .13 in/sec. $NPSH_R$ at full capacity was well within the two feet of $NPSH$ margin previously established. Subsequent to the factory testing, the pump was then commissioned in the refinery for the real test. Obviously, the pump was now secured to a grouted base while sufficient suction and discharge piping forces were imposed. Reading like a script, the parameters of flow and discharge were achieved. Vibration levels were monitored and proved satisfactorily in the range of .12 IPS. As an added benefit, operators now notice both pumps' flows are much more stable than before the rerate. As expected, the mechanical reliability has improved significantly. These pumps have not experienced a failure since their installation on August 15, 1996.

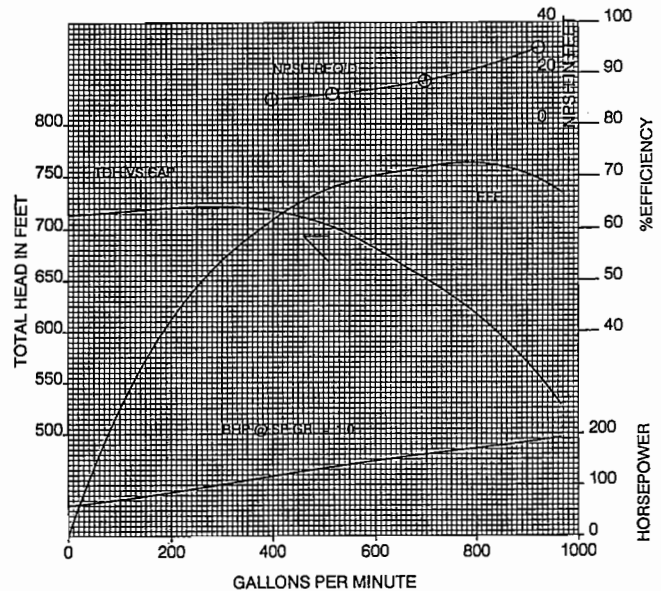

Figure 13. Actual Performance Curve of One of the Rerated Pumps (Case Study #1).

**RERATE CASE STUDY #2—
700 HP HOT OIL PUMPS**

Two (main and spare) 12 × 14 × 23 double suction, between bearing pumps, rated for 5510 gpm and designed to pump hot oil at 500°F, were installed in 1976. Both pumps are directly coupled to 700 hp electric motors. Together, they experienced the failure histories (from 1992 to 1995) shown in Table 3.

Table 3. Combined Failure History of Both Pumps (Case Study #2).

Year	Number of Failures
1992	3
1993	5
1994	3

The average of over three failures per year (MTBF < 1/3 year) was considered unacceptable. For this reason, an investigation into the root cause of these failures was initiated.

A hydraulic mismatch was suspected because of noisy pump operation. Furthermore, a year before the rerate, dynamic pressure pulsation levels in excess of 40 psi (peak-to-peak) were measured in the discharge piping, supported the theory that hydraulic

instability was the cause of the high failure rates. To confirm this, the impeller suction specific speed was determined along with the percent of BEP for the present operating condition. It was determined the N_{ss} was 11,150, which is considered marginally high. To compound matters, the Q_{actual}/Q_{bep} was determined to be about 62 percent, which is considered marginal by Dufour and Nelson (1993). Using Fraser's (1981) approach, it can be seen that a double suction impeller D_s , with an N_{ss} of 11,150, a minimum flow of 82 percent of BEP is suggested (Figure 7). (Note: For hydrocarbons, Fraser (1981) recommends using 60 percent to 75 percent of these flows—which would mean flows 50 percent to 62 percent of BEP could be tolerated.) The survey of minimum flow guidelines strongly suggested hydraulic instability at off-design conditions was occurring.

The unacceptable failure history of these pumps led the authors to consider a hydraulic rerate. An extended outage of the operating unit where these pumps resided provided the opportunity to remove and modify them extensively. The two conditions required for a rerate were present: a redesigned impeller capable of delivering the required hydraulic performance was available, and there was excess $NPSH_A$ required for the smaller impeller eye and lower N_{ss} . Table 4 compares the original and the proposed impeller characteristics.

Table 4. The Original and Proposed Impeller Characteristics (Case Study #2).

	Original Design	Proposed Design
Design flow (rated)	4521 gpm	4521 gpm
Pump/Impeller size	12" x 14" x 23"	10" x 14" x 20"
BEP flow	7259 gpm	5000 gpm
Volute throat area	34.4 in ²	27.75 in ²
Q_{design}/Q_{bep}	62%	82%
N_{ss}	11,150	8,530
Q_{min} (est)*	4355 - 5100 gpm	1900 - 3300 gpm

* Based on several methods

Figure 14 compares the original and proposed performance curves. As in the previous case study, the proposed impeller has its best efficiency point farther to the left and closer to the rated flow point than the original impeller. Because of the marked improvements in the hydraulic fit and allowable operating range, it was decided to proceed with the modifications required for the rerate. As mentioned before, another very attractive benefit of the rerate was that it would not require any changes to the piping, baseplate, driver, or coupling.

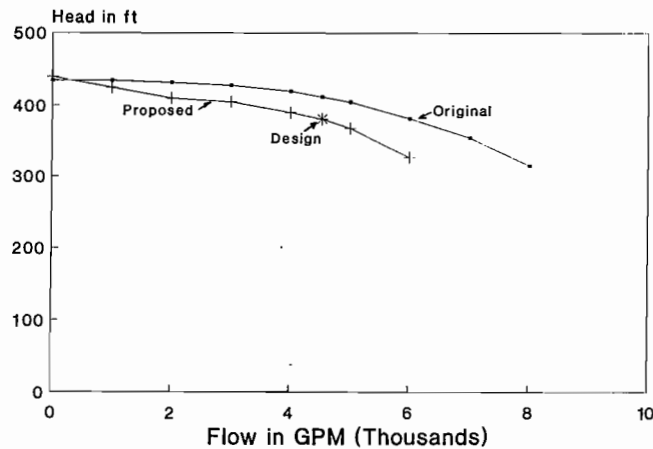

Figure 14. Comparison of the Original and Proposed Performance Curves (Case Study #2).

HYDRAULIC AND MECHANICAL DESIGN DETAILS

Similar to the first case study, this pump was also hydraulically rerated by using a redesigned impeller with a corresponding

modification of the volutes. The primary difference between this and the first rerate was that additional significant mechanical improvements were incorporated into this larger and higher horsepower pump. Since the original design point of the pump was 7259 gpm and the BEP was brought back to 5000 gpm, it was necessary to reduce the area of the volute from 34.4 in² to 27.75 in², while incorporating a new lower flow impeller. Additional $NPSH_A$ was verified. Therefore, it became possible to also reduce the suction specific speed of the impeller, and it consequently improved from 11,150 to 8530, thereby allowing a more favorable operating range.

While dropping a geometrically smaller impeller into an existing volute sounds simple, many physical alterations had to be made. Most importantly, the casing and cover wear rings had to be redesigned to converge (Figure 15) toward the narrower impeller while maintaining a smaller bore, since the impeller eyes were now smaller as well. Just as critical, the modification required to the volute areas was carried out as previously described in Case Study #1. Referring to Figures 16 and 17, the reader can ascertain that both volute cutwaters were removed (with much discussion as to the exact location of volute removal) and replaced with similar metallurgy volutes. The impeller suction, discharge, and corresponding volute areas now together would contribute to a lower flow operation conducive to reliable operation.

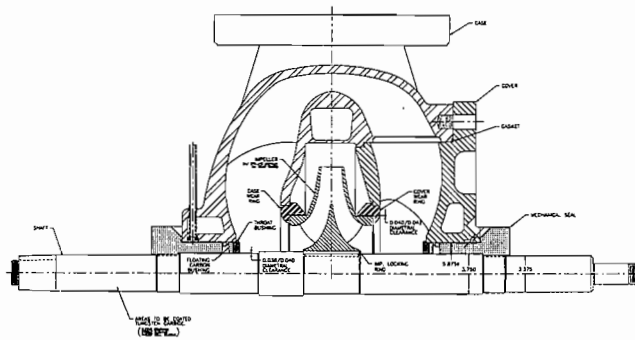

Figure 15. Cross Section of Rerated Double Suction Pump (Case Study #2).



Figure 16. Transition Region of Modified Volute (Before).

Based on the fact that this pump operated in a 500°F heavy vacuum gas oil (HVGO) with entrained solids (which are abrasive to the base metal of the volute), enhanced metallurgies were introduced during the rerate. Reviewing Figure 15, these upgraded metallurgies included the impeller, the surfaces of both the case and cover wear rings, the pump shaft journals, and the throat bushings. The impeller was upgraded from carbon steel to that of CA6NM, promoting additional corrosion resistance, a tougher and more durable carbon alloy with nickel and molybdenum

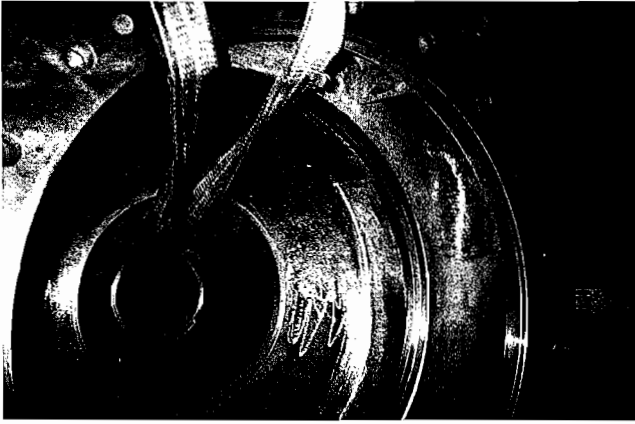

Figure 17. Transition Region of Modified Volute (After).

constituents, thereby promoting enhanced weldability. As this new impeller arrived in the form of a raw casting, it became practical to utilize the advantage of the added material on the shrouds, ring turns, and bore; therefore, the ring turns were machined to enable a welded overlay of stellite #6 (with four to six percent WC_2). The application of the cobalt based stellite was performed with the service center's plasma transferred arc (PTA) welding machine. This process introduces the stellite in an atomized welding powder through a constricted nozzle, where the metal deposition is introduced onto the base metal (impeller journal) with a minimal amount of heat input (comparative to the standard MIG and TIG methods of welding), to maintain the lowest level of dilution possible. This PTA process ensures that the bonding strength of the overlay meets the ultimate tensile strength (UTS) of the parent metal, while providing a superior wearing surface that is virtually nongalling when compared with alternate heat treated stainless coatings. A final impeller modification was that of designing the thrust end impeller wear ring smaller (.125 in) than the opposing wear ring, in order to create an approximate 500 lb load on the thrust bearing, essentially keeping the shaft in tension and preventing the rotor from "shuttling" when a perfect axial hydraulic balance occurs. In addition to the impeller wear ring journals, the casing and cover wear rings were also PTA overlaid. To create a 10 Rc hardness differential with the impeller, a harder grade of stellite was used, stellite #1, which supplies a higher level of WC_2 (10 to 12 percent) in the cobalt matrix. Both of the throat bushings were also upgraded to incorporate the #1 grade of stellite, and the shaft journal under the throat bushing was coated with a tungsten carbide layer applied by a high velocity spray process, thereby keeping heat input to the shaft to acceptable levels. Additionally, both sleeve bearing journals and the thrust bearing journal were tungsten carbide coated.

There were modifications made to each of the stuffing boxes to permit new cartridge bellows seals to be installed. Both stuffing boxes were bored .125 in oversize to enable larger bellows to be used and the pumping ring flow was improved by milling of the stuffing box where the bleed-off line intersected the stuffing box bore, to act as a "cutwater." Finally, the stuffing box redesign included the use of floating carbon bushings, which were now suspended around the shaft that also incorporated a dense layer of tungsten carbide. The cover (head) was further machined to modify the old gasket arrangement, which originally called for braided gasketing. Both of the internal cover shoulders were machined (including the corresponding casing shoulders) to allow for two confined flexicarb stainless sheathed, spiral wound gaskets to permit a calculated crush, once metal-to-metal face contact was made between the casing and cover. This upgrade also promoted parallelism of the cover, since both case and cover faces were fully machined, and this design negates the requirement for the mechanics to "travel" around the cover perimeter with a feeler gauge.

The pump shaft required minor modifications, a few of which were mentioned previously. One significant revision to the design was to create a locating shoulder for the impeller. This shoulder would now carry the hydraulic thrust imposed by the impeller, whereas the original design provided a mere .062 in spiralox retaining ring to carry thrust.

RESULTS OF THE RERATE

Performance testing at the factory was necessary to prove that the rerate and modifications were satisfactory. By reviewing the actual pump test data, Figure 18, it can be seen that at 1780 rpm, the capacity at differential was met. The efficiency of the pump exceeded the estimated 82 percent efficiency by 4.7 percent, and the corresponding vibration at 4529 gpm was .09 to .11 IPS. The two pumps have not experienced a failure since their installation in September 1995. Operators have noticed the pumps are much quieter than before and that pressure pulsations have been significantly reduced.

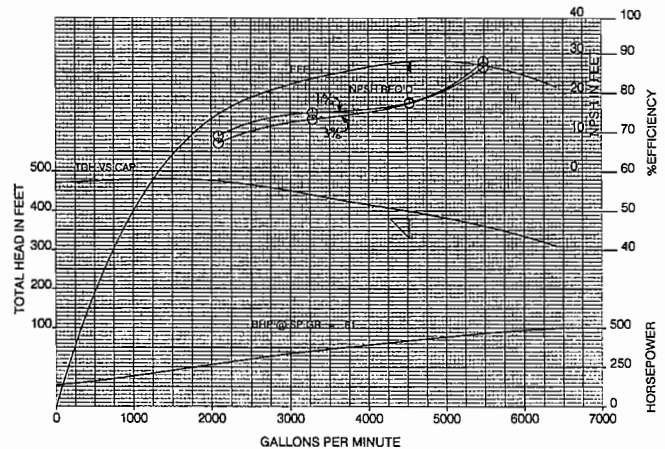

Figure 18. Performance Curve from One of the Rerated Double Suction Pumps (Case Study #2).

CLOSING REMARKS

When performed properly, hydraulic rerates offer users an effective solution to misapplied critical pumps. While rerates are implemented, users should take the opportunity to also improve the mechanical design of their pumps. The following general rerate guidelines are aimed at helping users improve the overall pump reliability of their pumps.

General Rerate Guidelines

- Move the actual operating flow closer to the impeller's best efficiency point by moving the new BEP to the left. This is done by matching a lower flow impeller with the required reduced volute throat area.
- Reduce the suction specific speed well below 11,000, if possible, to increase the operating flow range of the pump.
- Upgrade the rotor support system to API standards, if possible.
- Upgrade the mechanical seal design to API standards, if possible.
- Implement metallurgical, gasketing, and other technological upgrades wherever possible.

Users should realize the hydraulic rerate solution is only one tool in a pump specialist's toolbox of reliability improvement solutions. Like many other design improvements, if misapplied, rerates will not be completely effective and provide the resultant return of investment. To attain the maximum benefits of this

method, users should judiciously select rerate candidates. When applied properly, the rerate solution can solve the most notorious pump problems in your plant, placing the proverbial feather in your cap, while allowing you to move forward and focus on the next reliability improvement.

APPENDIX A

Typical Calculation Procedure for Rerates

After the decision regarding the location of BEP for the rerate is made, it is necessary to select the impeller and volute geometries to provide the desired BEP. In general, there are no direct methods to arrive at the geometry from required flow conditions. Therefore, typically an impeller/volute selection is made and its characteristics examined through flow analysis.

The key hydraulic characteristics to be verified for the impeller are:

- Shockless entry flow.
- Incidence angle of the flow with respect to the vane over the range of intended flows.
- The NPSH inception numbers over the range of intended flows.
- The minimum continuous flow for safe operation.
- The required NPSH and margin with respect to available NPSH.

The computational techniques for estimating the above are described in Gopalakrishnan (1985). The calculations must be done for the existing design and the proposed rerate design. Table A-1 summarizes the key hydraulic results for CASE STUDY 1—300 HP LEAN AMINE PUMPS.

Table A-1. Key Hydraulic Results for Case Study #1.

	Original Design	Proposed Rerate Design
Pump Designation	4 × 6 × 13	3 × 4 × 13
Shockless entry flow (gpm)	1200	880
• Incidence angle (deg)		
400 gpm	6.3	10.6
600 gpm	4.7	6.1
800 gpm	3.1	1.7
1000 gpm	1.5	-2.4
NPSH _i (ft)		
400 gpm	310	275
600 gpm	178	140
800 gpm	93	30
1000 gpm	58	38
Minimum continuous flow (gpm)	700	275
NPSH _R (ft) at BEP	16	22
NPSH _A (ft) at design	30	30

It can be seen from Table A-1, that the rerate brings the shockless entry point very close to the upper end of the design operating range, while in the original design the shockless entry point was far in excess of the design range. It can also be seen that with the rerate, near the peak design flow with the available NPSH of about 30 ft, the impeller will operate with almost no cavitation activity.

The comparison of the minimum continuous flow is also revealing. The original MCSF was 700 gpm, and the pump was operating routinely below that condition down to about 400 gpm. With the rerate, MCSF is 275 gpm allowing stable operation through the entire design range.

It must be remembered that the volute area also must be adjusted when the operating point needs to be changed as much as in this case. The volute area change required can be estimated preliminarily from the charts provided, for example in Lobanoff and Ross (1992). Computation of the H-Q curve resulting from this choice can be done using modern CFO codes. While this is feasible, it is not practical in most cases to go through this effort. Reference must be made to past hydraulic data to finalize the volute area choice.

REFERENCES

- API 610, 1995, Eighth Edition.
- Dufour, J. D. and Nelson, W. E., 1993, *Centrifugal Pump Sourcebook*, New York, New York: McGraw-Hill, Inc.
- Florjancic, S. and Frei, A., 1993, "Dynamic Loading of Pumps—Causes for Vibration," *Proceedings of the Tenth International Pump Users Symposium*, Turbomachinery Laboratory, Texas A&M University, College Station, Texas, pp. 171-184.
- Fraser, W. H., 1981, "Flow Recirculation in Centrifugal Pumps," *Proceedings of the Tenth Turbomachinery Symposium*, Turbomachinery Laboratory, Texas A&M University, College Station, Texas, pp. 95-100.
- Gopalakrishnan, S., 1985, "Modern Cavitation Criteria for Centrifugal Pumps," *Proceedings of the Second International Pump Symposium*, Turbomachinery Laboratory, Texas A&M University, College Station, Texas, pp. 3-10.
- Hallam, J. L., April 1982, "Centrifugal Pumps: Which Suction Specific Speeds are Acceptable?" *Hydrocarbon Processing Magazine*.
- Heald, C. C., July 1996, "What is Minimum Flow?" *Plant Services Magazine*.
- Lobanoff, V. S. and Ross, R. R., 1992, "Centrifugal Pumps: Design and Application, Second Edition," Gulf Publishing Company, pp. 90-93.
- Nelson, W. E., 1984, "Maintenance and Troubleshooting of Single-Stage Centrifugal Pumps," *Proceedings of the First International Pump Symposium*, Turbomachinery Laboratory, Texas A&M University, College Station, Texas, pp. 73-84.

ACKNOWLEDGEMENT

The authors would like to thank S. Gopalakrishnan of Flowserve Corporation for his encouragement and for his work on APPENDIX A of this paper.