

HYBRID PUMP— A NEW TYPE OF PUMP FOR THE PAZFLOR DEEP SEA PROJECT

by

Pierre-Jean Bibet

Senior Rotating Equipment Engineer

Total

Courbevoie, France

Bernard Quoix

Head of Rotating Machinery Department

Total

Pau, France

and

Haakon Grimstad

Head of R&D, Subsea and Rotating Machinery Departments

Framo Engineering

Bergen, Norway



Pierre-Jean Bibet is a Senior Rotating Equipment Engineer at Total E&P, in Paris, France, working in the Rotating Machinery Department since 2003. In this position, relying on 13 years of professional experience with pumps, he is dedicated to Subsea Boosting Projects, with a special focus on multiphase pumps. He previously worked for Sulzer Pumps France as Technical Coordinator for the multiphase

pump product, covering pump specification, testing, commissioning, technical support, and troubleshooting.

Mr. Bibet graduated (Mechanical Engineer, 1986) from Ecole Supérieure de l'Énergie et des Matériaux.



Haakon Grimstad is Technical Manager at Framo Engineering, in Bergen, Norway, responsible for the R&D, Subsea, and Rotating Machinery Departments. He started with Framo Engineering in 1985 and has since held various positions primarily related to development, commercialization, and delivery of new technology such as multiphase flowmeters, multiphase boosting, wet gas compression, and subsea pumping systems.

Mr. Grimstad graduated (Mechanical Engineer, 1983) from the Norwegian University of Technology. Pierre-Jean Bibet is a Senior Rotating Equipment Engineer at Total E&P, in Paris, France, working in the Rotating Machinery Department since 2003. In this position, relying on 13 years of professional experience with pumps, he is dedicated to Subsea Boosting Projects, with a special focus on multiphase pumps. He previously worked for Sulzer Pumps France as Technical Coordinator for the multiphase pump product, covering pump specification, testing, commissioning, technical support, and troubleshooting.



Bernard Quoix is the Head of Total E&P Rotating Machinery Department, in Pau, France, and has held this position since November 2003. He began his career in 1979 within Total Operations in the North Sea, then from 1986 to 1989 became Head of Engineering of Turbomeca Industrial Division, a small and medium size gas turbine manufacturer. Mr. Quoix then went to Renault as Assistant Manager of the

testing facilities for prototype and production engines before joining Elf Aquitaine and, eventually, Total, where he was mainly involved in all aspects of turbomachines, including conceptual studies and projects for new oil and gas field development, bringing his expertise to all Total Affiliates Operations.

Mr. Quoix graduated from Ecole Nationale Supérieure d'Électricité et de Mécanique (1978), and then completed his engineering education with one additional year at Ecole Nationale du Pétrole et des Moteurs, specializing in internal combustion engines.

ABSTRACT

Subsea processing gives pump engineers permanent technical challenges due to the comprehensive specifications that often stretch the proven limits of technology. It is particularly true for pumps that have to boost a multiphase effluent.

This paper presents the state-of-the-art of the centrifugal or multiphase pumps that are designed to be installed on the sea floor. It then describes why the existing technology could not match the technical requirement of a deep sea project for which the development scheme relied on a gas/liquid subsea separation, and pumping of the mixture of liquid and gas carried-under. It finally presents the pump technology specifically developed for this world first full field development application, the hybrid pump.

INTRODUCTION

Subsea processing represents significant design challenges due to the comprehensive specifications that often stretch the proven limits of technology. This paper focuses specifically on subsea pump technology for which the tasks are numerous, such as to:

- Manage the constraints linked to immersion and high water depth,
- Manage the constraints induced by the remote distance to the topside asset,
- Generate a high ΔP ,
- Pump a very viscous fluid,
- Work with various gas volume fractions (GVF),
- Have good efficiency because the available shaft power is limited,
- Be tolerant to any fluctuation coming from the process,
- Be tolerant to sand, and
- Ensure the operators a mean time between failures (MTBF) of at least five years!

The Pazflor project decided to base the development on full utilization of subsea pumps. Field descriptions as well as pump specifications for Pazflor are given as a background to the evaluation of alternative pump solutions considered for the application.

The paper further describes why existing technology could not match the technical requirements for the Pazflor project for which the development scheme relies on a gas/liquid subsea separation and pumping of the mixture liquid/gas carried-under. Finally, the pump technology specifically developed for this world first full field development application and the associated qualification program are described.

Henceforth, in this paper, manufacturer 1 refers to Framo Engineering, and manufacturer 2 refers to AkerSolutions.

PAZFLOR PROJECT

In order to produce the Miocene fields of the Pazflor development, a significant artificial lift is required, mainly due to the low reservoir pressures and the quality of the oils. Given the relatively “shallow” water depth (2625 ft, 800 m) and the high viscosity of the oils, bottom riser gas-lift alone is not efficient enough to reach the required production plateau; an additional/alternative artificial lift technology is required. This need for “heavy” artificial lift is linked to:

- The relatively degraded quality of the oil (heavy and viscous),
- Its tendency to form strong emulsions (an emulsion increases the viscosity thus increasing the pressure losses by friction),
- The low reservoir pressure, and
- The rapid decrease of wellhead flowing pressure (WHFP) due to increasing water cut.

Different scenarios have been studied, out of which the subsea gas/liquid separation and liquid boosting appeared to be the most attractive both in technical and economical aspects.

With a subsea gas/liquid separation and liquid boosting architecture, the wells are produced through single multiphase production lines, connected to a gas/liquid subsea separator located at the mud line close to the first well. The separated gas flows naturally to floating production storage and off-loading (FPSO) via a dual gas riser system. The separated liquids (oil and water) are boosted to surface by two subsea liquid pumps via a liquid riser (Figure 1).

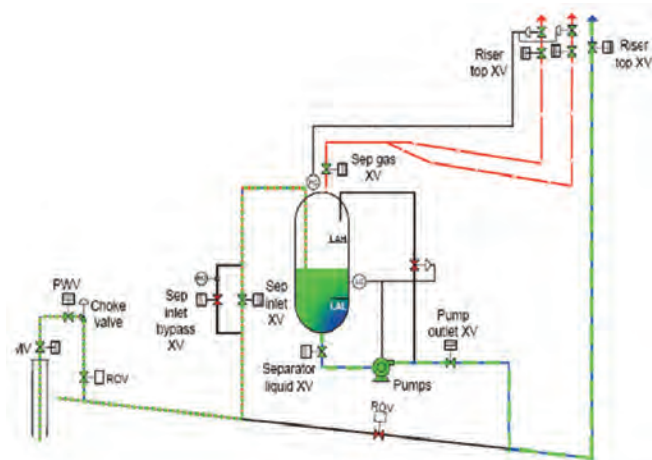

Figure 1. Pazflor Subsea Gas/Liquid Separation and Liquid Boosting Architecture.

PUMPING REQUIREMENT

The Pazflor pump specification was very demanding and went beyond what is normally required either subsea or topside. Indeed the pumping requirement was to find a pump capable at the same time of:

- Generating a high ΔP (1522 psi, 105 bar), for a suction pressure of 333 psia (23 bara), a flow of 53,000 bpd (350 m³/h), and a viscosity of 250 cP.
- Handling a highly viscous fluid during startup (up to 4500 cP).
- Working with high GVF (15 percent for the base case, and 40 percent for unexpected fluid behavior).
- Being efficient because available power subsea is limited to 3350 hp (2.5 MW) today.

The critical challenge for the pump engineer was therefore to find the pump tolerant to free gas, and able to pump very viscous oil and able to generate high ΔP efficiently.

STATE-OF-THE-ART ON SUBSEA PUMPING TECHNOLOGY

In the oil and gas world of subsea processing, two types of applications may require subsea pumping: water injection and multiphase boosting. Two sorts of subsea pumps have been specifically designed by the manufacturers for installation on the sea floor. Manufacturer 1 and manufacturer 2 are the only two pump manufacturers capable of proposing today a qualified subsea pumping solution, with the respective technologies shown in Table 1. Of course, differences in technology mean different domain of application from one pump to the other. So how do these technologies differ?

Table 1. Respective Subsea Technologies.

	Water Injection	Multiphase Boosting
Framo	Centrifugal Pumps	Helicoaxial MPP
AkerSolutions	Centrifugal Pump (LiquidBooster)	Twin-screw MPP

Key Difference Between Manufacturer 1 and Manufacturer 2 Centrifugal Pumps

Three key differences in the two proposed designs (shown in Figures 2 and 3) can be highlighted:

- Motor/pump integration
- Type of barrier fluid
- Impeller arrangement



Figure 2. Manufacturer 2 Liquid Booster. (Courtesy of Aker)

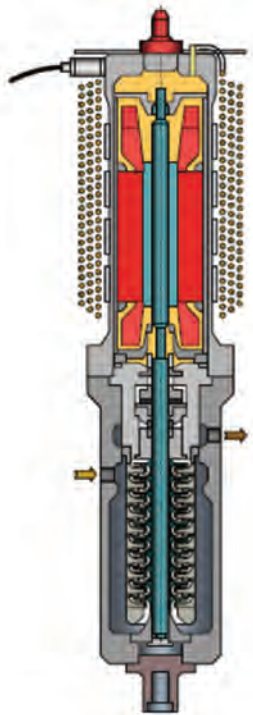

Figure 3. Manufacturer 1 Subsea Single Phase Pump.

Key Difference #1: Motor/Pump Integration

The manufacturer 2 motor and pump are an integrated design, i.e., the pump and the motor are designed as a complete machine. This means that the two shafts are rigidly coupled, and that there is only one thrust bearing.

The manufacturer 1 pump is of a more conventional design, i.e., the pump and the motor are individual machines, with their own journal and thrust bearings. The two shafts are coupled by a flexible coupling.

Both solutions have a single pressure containing housing for the motor and pump unit.

Key Difference #2: Type of Barrier Fluid

The manufacturer 2 centrifugal pump is driven by a water glycol-filled motor. This has a direct impact on the type of bearings

used in this technology. The bearings are in silicon carbide because they are water lubricated by the barrier fluid (freshwater glycol mixture).

The manufacturer 1 centrifugal pump is driven by an oil-filled motor, therefore the barrier fluid is oil with low viscosity. The bearings are more conventional, “standard” hydrodynamic bearings lubricated by oil with polymer pads.

Key Difference #3: Impeller Arrangement

The manufacturer 2 pump has a back-to-back impeller arrangement; it does therefore not require a balance piston. The back-to-back impeller arrangement balances the axial hydraulic thrust by their opposite arrangement and needs only a small thrust bearing to absorb the residual thrust. This is handled by the motor thrust bearing. This pump has a throttle bushing in the center of the pump made of silicon carbide, which sees half the total ΔP. This bearing is product lubricated (PLB). With this technology, the lower bearing can be PLB or not, potentially saving a mechanical seal.

Manufacturer 1 delivers a pump with an inline impeller arrangement. The inline impeller arrangement requires a balance piston if the ΔP is higher than 725 psi (50 bar).

In terms of existing experience, manufacturer 1 has four water injection pumps in operation today, and three others delivered. For manufacturer 2, the first subsea application for this pump will be a raw seawater injection pump for Tyrihans, to be delivered during the first quarter of 2009.

Depending on the project specification, these key design features can become technology advantages or drawbacks. Therefore, it is the responsibility of the pump engineer to perform the right technology evaluation and to select the most appropriate technology for his application.

For Pazflor, the free gas content was too high for these standard centrifugal pumps already qualified for subsea water injection. These centrifugal pumps have limited gas handling capacities (10 percent approximately, depending on viscosity and suction pressure and gas to liquid density ratio), hence these technologies were not able to meet the full specification.

Note: Compared to existing subsea references, the Pazflor project was really special by the type of fluid to be pumped (viscous oil with a lot of gas). This makes all the difference compared to usual water injection or oil export applications because this has an impact on the pump stability in operation (in fact this nonhomogenous fluid circulates through the wear rings and balance piston and can generate destabilizing forces). This is the reason why this project was handled as a multiphase pump application.

Key Differences Between Helicoaxial and Twin-Screw Multiphase Pumps

The differences between volumetric and rotodynamic pumps are well known. For an operator, the advantages/drawbacks of the technologies are evaluated as shown in Tables 2 and 3 and Figures 4 and 5.

Table 2. Advantages/Drawbacks of a Helicoaxial MPP

HELICO AXIAL MPP	
Advantages	Drawbacks
Technology simple. - Flow path open. - Large rotor/stator clearances - Two mechanical seals only	Torque variable with GVF. Requires protection from slugs.
Can run indefinitely with 100 percent gas as long as there is a net flow (but generating a very low ΔP). High Flexibility due to a wide operating envelope. No real intrinsic power limitation (state-of-the-art onshore is 8850 hp (6.6MW)). Can pump to dead head	High operating speed (3500 to 6000 rpm).
Several references both onshore, offshore and subsea.	

Table 3. Advantages/Drawbacks of a Twin-Screw MPP.

TWIN-SCREW MPP	
Advantages	Drawbacks
Volumetric pump, so the torque does not depend on the pumped fluid density.	Technology more complicated; <ul style="list-style-type: none"> - Flow path not straight forward. - Tight rotor/stator clearances. - Four mechanical seals at least. - Needs at least 3 percent liquid recirculation flow to seal the rotor/stator gap.
Very tolerant to unstable flows, does not require protection against slugs.	Pump volumetric efficiency very dependent on the rotor/stator clearance: <ul style="list-style-type: none"> - sensitive to fluid viscosity variation. - sensitive to water cut variation. - sensitive to wear
Run at low speed (800 to 1800 rpm typically).	Limited in ΔP due to shaft deflection.
	Still prototype for $\Delta P > 725$ psi (50 bar). Two subsea references only.

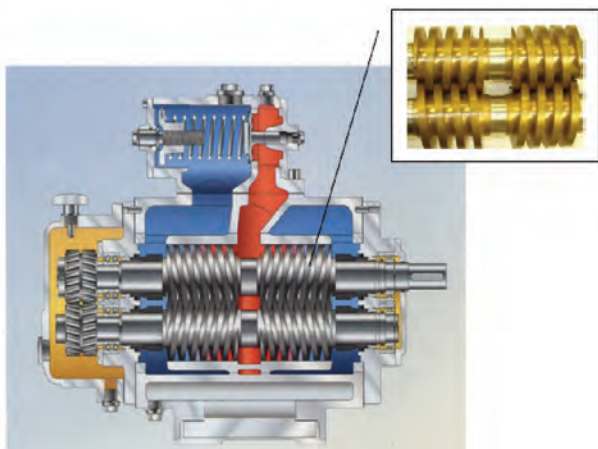

Figure 4. Manufacturer 2 Multiphase Pump. (Courtesy of Aker and Bornemann)

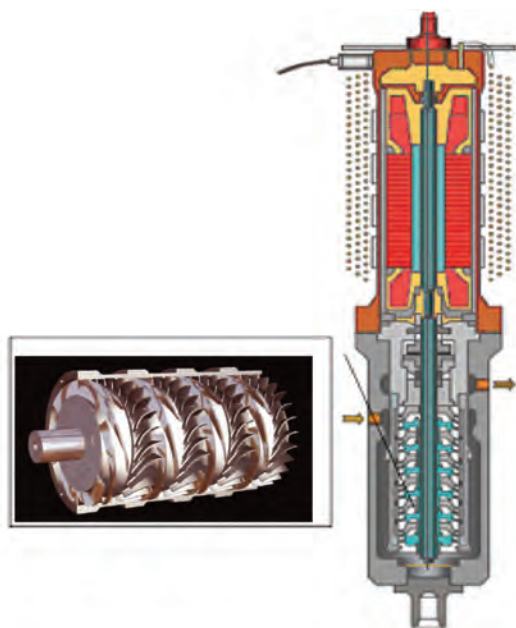

Figure 5. Manufacturer 1 Subsea Multiphase Pump.

In terms of existing experience, manufacturer 1 has 21 pumps in operation today subsea, and manufacturer 2 has three pumps in operation. Here again, both available technologies were not able to meet the full specification. The required ΔP was too high for the twin-screw pump technology, but also too high for standard

multiphase pumps already qualified and limited to a maximum ΔP of 725 psi (50 bar). The decision was therefore to develop and qualify the pump that would meet the requirements, the so-called “hybrid pump.”

Hybrid Pump

The idea of a hybrid pump is to assemble, on a common pump shaft, gas tolerant impellers with radial impellers, the first ones for their ability to handle free gas, and the others for their high performance and efficiency.

The hybrid pump selected for Pazflor is an eight-stage pump where the two first stages are helicoaxial impellers, and the six others are pure radial impellers. The two helicoaxial impellers generate enough pressure ratio to reduce the GVF below 10 percent at the first centrifugal impeller inlet. Both hydraulics were field-proven, except when operated at relatively high viscosity and/or GVF. Therefore a qualification program was established to demonstrate the performance and the viability of the hybrid pump concept, i.e., a sound design of the intermediate diffuser, and sound design of the balance piston with a multiphase flow (no existing reference, so far, subsea).

In a performance point of view, the main issue was to select the optimum impeller arrangement with regard to the specified viscosities, this because the viscosity effect is more pronounced on a helicoaxial impeller than for a radial impeller. As the pump must be designed for one operating condition, this means that everywhere else the two different types of hydraulics will never work at their best efficiency point (BEP) at the same time. The real challenge was thus to find the best compromise for the whole operating range.

A prototype machine was then built with two helicoaxial impellers upstream of two radial impellers identical to those proposed for Pazflor (Figures 6 and 7). This prototype 2H+2R included:

- The same impeller size as for the full-scale pump.
- The same intermediate diffuser design as for the full-scale pump.
- The same balance piston design and clearance as for the full-scale pump, but with a piston diameter slightly lower because of only four stages here. Therefore, it was also possible to totally characterize the performance of the balance piston with a viscous/gaseous leakage, both from a performance and rotodynamic point of view.



Figure 6. Hybrid Pump Prototype.

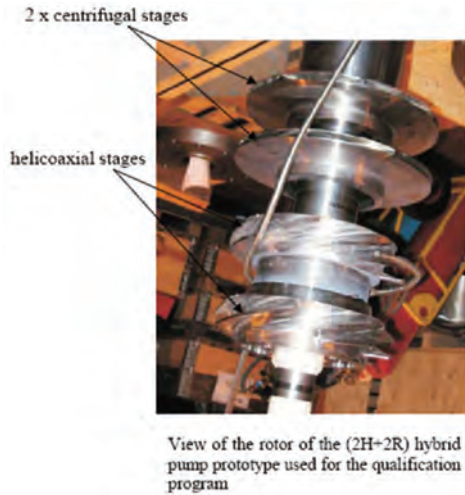

Figure 7. Hybrid Pump Prototype Rotor.

QUALIFICATION PROGRAM

The main objectives of the qualification program were to:

- Verify the hydraulic performance of a hybrid pump consisting of helicoaxial multiphase stages and radial centrifugal stages on the same shaft, for a range of fluid viscosities representative of Pazflor conditions, and various gas content. Focus was on the hydraulic and mechanical behavior of the hybrid pump including balance piston and the intermediate diffuser.
- Establish relevant viscosity correction diagrams for the hybrid pump.
- Establish performance of the balance piston (BP): impact on the rotodynamic behavior, leakage rate, and temperature rise across the piston.
- Establish performance of the intermediate diffuser. The intermediate diffuser is not supposed to generate a large head; however it has a significant influence on the performance of the downstream impeller. The performance of the intermediate diffuser is therefore indirectly expressed by the performance of the downstream radial hydraulics.

The test program was performed between Q3 2006 and Q1 2007. The main results are presented hereafter.

TEST RESULTS—HYBRID TEST PUMP

Single Phase Fresh Water

Figure 8 compares predicted performance (solid lines) versus test results (points). The performance for water without gas is in very good agreement with the estimated performance. As can be seen the performance is slightly better than expected at relatively higher capacities, and this response is consistent at increasing speeds.

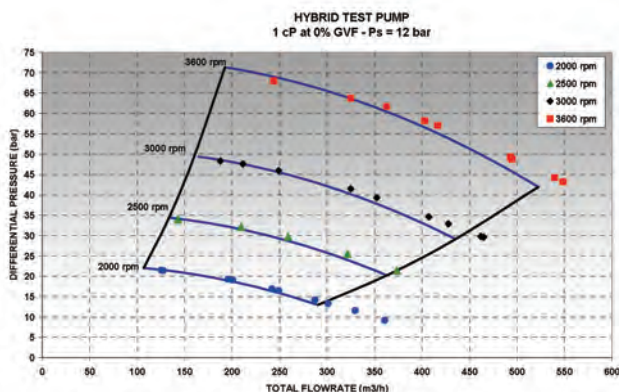

Figure 8. Estimated Versus Tested Performance—1 cP at 0 Percent GVF.

The reason is that design conditions for the pump and motor rating are based on the high viscosity case (250 cP). At lower viscosities, the nominal flow for the helicoaxial hydraulics is higher and the relative flows correspondingly lower. This means that when running with water, the impellers are outside the normal operating range and the extrapolation was too pessimistic.

Two Phase Fresh Water and Gas

Figure 9 compares predictions and test with 15 percent GVF at pump inlet. Performance with added gas is better than expected, particularly at the higher speed.

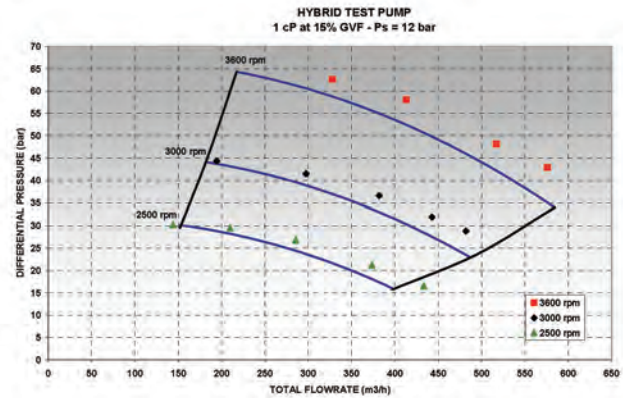

Figure 9. Estimated Versus Tested Performance—1 cP at 15 Percent GVF.

The effect of GVF on the pump performance has several consequences. First the differential pressure for a given head will be reduced as the mixture density reduces with increasing GVF. Secondly, the fluid will experience a reduction in volume as the gas is being compressed through the pump. Due to this, the intermediate diffuser and last impellers will operate at lower flow rates depending on the gas volume fraction into the pump and the pump pressure ratio. The reduced internal flow rate will result in an increased head, in particular at relatively high capacities where the performance curve of the radial impellers is steeper.

Figure 10 demonstrates the reduction of flow rate before the radial impellers and how this affects the differential pressure across the pump.

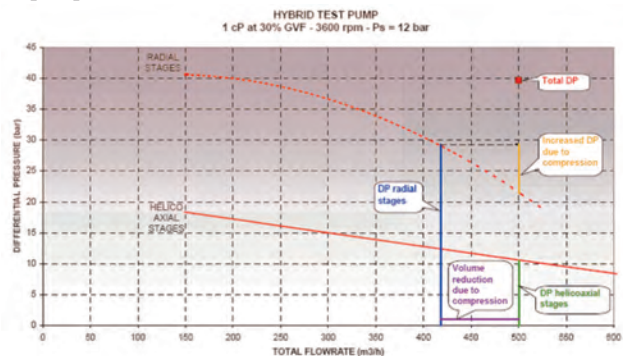

Figure 10 Volumetric Flow Reduction Through Helicoaxial Stages.

Note: Data for the hydraulic performance are given in terms of differential pressure versus flow rate. Although head is commonly used for single-phase performance, it is not possible to define a consistent head basis when a multistage pump is operating on gas and liquids. This is because the mixture density will not be constant, but rather vary for each stage through the pump. Since the intermediate densities are not known, a head-based performance analysis will be very complicated. A differential pressure basis has been chosen in order to be consistent with the multiphase analysis.

Single Phase Viscous Oil

Centrifugal Impellers

Centrifugal impellers may not be the best solution for pumping very high viscosities. The economical duty limit for centrifugal pumps is approximately 500 cP. However, the performance impairment can be well predicted with Hydraulic Institute correction factors, or original equipment manufacturer (OEM) in-house test data. Hydraulic Institute test results show that high viscosity for a centrifugal pump means:

- Significant reduction of flow.
- Marginal impact on head.

A centrifugal pump for a viscous duty can therefore be designed for a greater flow rate to keep the head, using the correction factors given by the Hydraulic Institute (refer to Equations (1) and (2)) or coming from OEM test results:

$$Q_{water} = \frac{Q_{viscous}}{C_Q} \tag{1}$$

$$H_{water} = \frac{H_{viscous}}{C_H} \tag{2}$$

(The correction factors are the relative difference in BEP between a situation with low viscosity and a situation with high viscosity.) It is therefore possible to build the pump for a viscous fluid based on know-how with water. The absorbed power then becomes:

$$P_{viscous} = \frac{\rho_{viscous} \times Q_{viscous} \times H_{viscous}}{\eta_w \times C_H} \tag{3}$$

Equation (3) shows that C_Q and C_H are only dimensioning factors of the pump; they do not affect the efficiency. C_η is the only impairment factor that affects the absorbed power. A centrifugal pump for viscous oil can easily be sized in terms of flow and head because it is just a matter of “oversizing” the impeller. The only issue is to evaluate C_η to determine the required absorbed power.

For the hydraulic design of the Pazflor hybrid pumps, the viscosity effects on the radial impellers section were assumed to comply reasonably well with the correction factors as from the Hydraulic Institute.

Helicoaxial Impellers

The hybrid test pump was equipped with a pressure probe in the intermediate diffuser between the two different hydraulic series. Therefore, it was possible to evaluate the individual performances of the impeller sections.

For a helicoaxial impeller, the basic findings were that the qualitative effect of viscosity on the characteristic curves is similar to that prescribed by the Hydraulic Institute. However due to the greater importance of losses because of the increased channel length compared to a single-phase centrifugal pump, a helicoaxial multiphase pump (MPP) has a more significant reduction in flow, and the head at BEP is in fact slightly increasing with increasing viscosity. The helicoaxial impeller can be seen as if the viscous flow was acting like some sort of choke valve with the reduced flow giving just a minor impact on head. So MPP in viscous flow compared to a centrifugal pump is:

- Minor reduction in head,
- More significant reduction in flow, and
- More significant loss in efficiency.

As for a centrifugal pump, MPP for a viscous duty is designed for a higher flow rate to keep the head.

Test results showed that the viscosity effect on the performance envelope was to shift the performance characteristics and BEP to a lower capacity and a lower head. This effect is shown in Figure 11 for the helicoaxial hydraulics, which is more influenced by viscosity than the radial hydraulics. As mentioned earlier, one of the design challenges with the hybrid pump was to choose the design viscosity for which the BEP of the two hydraulics should match, compromising slightly the peak performance for other viscosities. On the other hand, a reduced peak performance at “off-design” viscosities will lead to increased performance at low and high capacities for these viscosities.

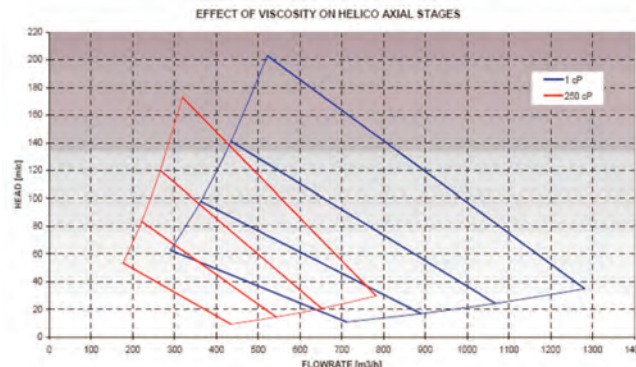

Figure 11. Effect of Viscosity on Helicoaxial Capacity Range.

The performance curves in Figure 12 are compared at a pump speed of 3600 rpm in order to visualize the impact of viscosity. The impact of the higher viscosities is reduced in relative terms as viscosity is increased. Viscosity increases at the lower flow rates almost become insignificant for this pump above 50 cP, whereas the required speed compensation from 1 cP remains unchanged.

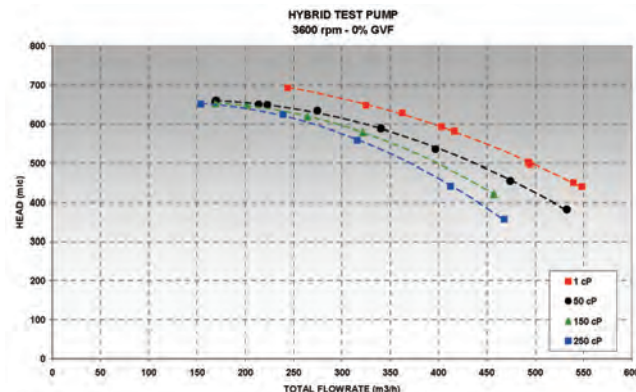

Figure 12. Effect of viscosity with 0 Percent GVF.

For the higher flow rates, say at around 68,000 bpd (450 m³/h), the applicable viscosity changes would have to be compensated for by the speed increases given in Table 4 in order to maintain original head at 1 cP.

Table 4. Speed Increase to Compensate for Increasing Viscosity.

PAZFLOR HYBRID PUMP		
Viscosity cP	Speed increase %	Power increase %
1	-	-
50	3	4
150	5	11
250	7	15

Two Phase Viscous Oil and Gas

Estimated Performance at
250 cP and 15 Percent GVF

This combination of high viscosity and gas fraction represents the main challenge and design requirement for the hydraulic design of the pump. Performance curves established for the base case of 250 cP and 15 percent gas volume fraction are shown in Figure 13.

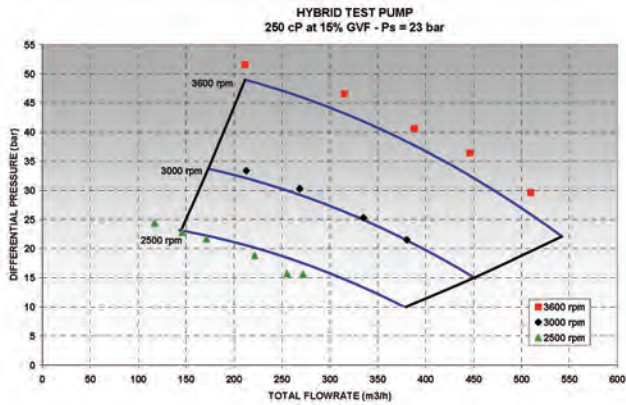

Figure 13. Estimated Versus Tested Performance—250 cP at 15 Percent GVF.

The differential pressure is in general 45 to 60 psi (3 to 4 bar) over what has been estimated for the design speed at 3600 rpm and is mainly related to the helicoaxial performance. The measured performance is according to design at about 3000 rpm.

Hydraulic performance with gas has been found to be higher than expected. A likely reason for this is a conservative design of the helicoaxial impellers with respect to viscosity correction based on liquid viscosity only. With increasing gas content a lower effective viscosity reduces the actual losses in the pump and thus contributes to a better than predicted performance.

Estimated Performance at
250 cP and 30 Percent GVF

This behavior is in line with the previous trends observed, where an increasingly higher performance is achieved beyond the estimated as the viscosity and GVF are raised (Figure 14).

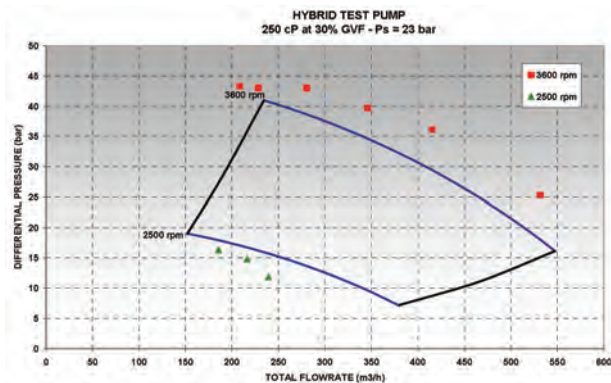

Figure 14. Estimated Versus Tested Performance—250 cP at 30 Percent GVF.

Reduced Suction Pressure

In order to investigate the impact of a higher density ratio of liquid and gas, the pump was operated at a few selected points at reduced suction pressure. According to the fluid properties and field operating conditions, a suction pressure of 116 psi (8 bara) is representative of typical field conditions in terms of density ratio.

The results presented in Figure 15 show that at low speed (2500 rpm) the differential pressure generated is less at reduced suction pressure, while at higher speed (3600 rpm), the differential pressure generated is apparently not influenced by the suction pressure. However, it should be noted that the pressure influence observed is a result of several effects. In particular a reduced suction pressure will result in lower gas density and hence lower differential pressure generated by the first stages. It will also result in a higher pressure ratio, particularly at higher speeds, which then again result in reduced flow rate, reduced GVF, and increased mixture density at the last stages tending to increase the differential pressure generated.

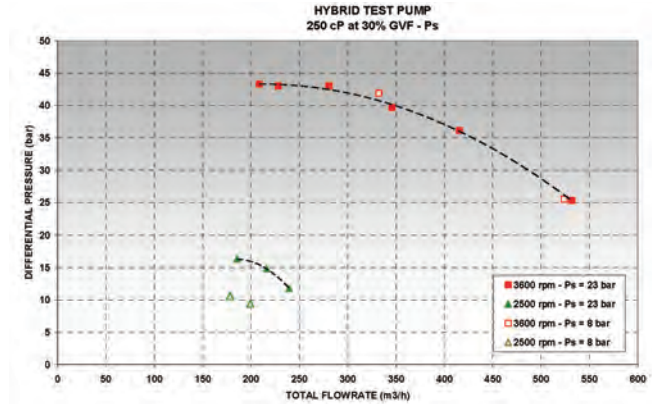

Figure 15. Influence from Suction Pressure.

Balance Piston

As previously mentioned, the thrust balancing by use of a balance piston/drum arrangement was an important part of the design and hence the qualification testing. Although commonly used in single-phase pumps, the challenges of operation with unprocessed well fluids and free gas require special attention.

There was no doubt that the thrust balancing functionality would be maintained with multiphase fluids. The principle of the balance piston is basically to constitute a pressure drop given by and equal to the pump differential pressure, over a given diameter of the shaft (balance piston), thus providing a counter-force to the axial thrust provided by the pump impellers. Challenges for the Pazflor application were however related to the following aspects:

- **Volumetric and viscous losses**—Generally the primary disadvantage of balance piston arrangements is the volumetric losses due to the leakage of fluid from the pump discharge side past the balance piston and back to pump suction. From a hydraulic point of view the clearance between the balance piston and the stationary balance drum should thus be as small as possible in order to keep the volumetric losses low.

The leakage rate across the balance piston of the test pump was established by closing the return line from the balance piston outlet chamber back to pump suction. At stable conditions the flow rate and differential pressure were measured with this line open and closed at various capacities, which basically provided two performance curves. These curves allow for a proper comparison of flow at the same differential pressure.

With increasing GVF, volumetric efficiency does fall slightly as expected. However this is more than counterbalanced by increasing viscosity, which reduces the volumetric losses over the balance piston significantly.

Increasing viscosity does however lead to higher viscous losses over the balance piston and with higher viscous losses and reduced leakage flow, temperature increases more over the balance piston. However, the temperature increase for the applicable operating conditions is less than 86°F (30°C), and will be within the design limit of the balance piston. The viscous case scenarios are also basically due to the formation of emulsion, where the presence of

water will reduce the temperature increase due to its higher heat capacity (by a factor of approximately two-thirds at 50 percent water cut [WC]).

Furthermore, results showed that the temperature rise over the balance piston when operating on viscous oils generally reduces with increasing differential pressure for the various viscous cases. From a hydraulic perspective, this observation is fairly reasonable, in that the thermodynamic balance of frictional and volumetric losses counterbalance each other. With higher differential pressure, the leakage rate will increase more than the frictional losses and temperature will thus increase less.

- **Rotordynamics**—Based on the large variations in fluid conditions specified for the Pazflor field, rotordynamics for the pump in general and specifically related to the balance piston design required high attention and comprehensive simulation efforts. The operating conditions covered from pure water to 40 percent GVF combined with viscosities from less than 1 cP to 4500 cP during pump startup conditions.

The analysis focused on an optimized and rotordynamically stable balance piston design, given also the sometimes contradictory requirements for a mechanically robust design with minimum volumetric losses. Testing confirmed stable operation over the full operating range.

- **Wear resistance**—Although the flow path from the last stage impeller outlet to balance piston inlet is optimized such that the majority of impurities in the fluid will follow the main flow to pump discharge, the balance piston still must be designed for the presence of hard particles from the wells.

The solution to this challenge is to manufacture the balance drum in hard material such as solid tungsten carbide, while the balance piston can be coated with tungsten carbide or even in solid tungsten carbide as well (as already delivered in other manufacturer 1 subsea pumps). Extensive full-scale wear testing with almost pure quartz sand on very similar balance piston designs has proven the high robustness of this material combination for balance piston/drum arrangements.

Eventually, extensive wear will increase the clearance between balance piston and drum. This will lead to higher volumetric losses, in particular for lower viscosities. The rotordynamic stability is maintained or will even improve with increased balance piston clearances.

Intermediate Diffuser

The intermediate diffuser shall take the outlet flow from the last helicoaxial stage and route the flow from a “swirl pattern” to an axial one immediately upstream of the first centrifugal impeller. It can therefore be described as a combination of a conventional helicoaxial diffuser and a centrifugal diffuser. The design is illustrated in 3D image in Figure 16.

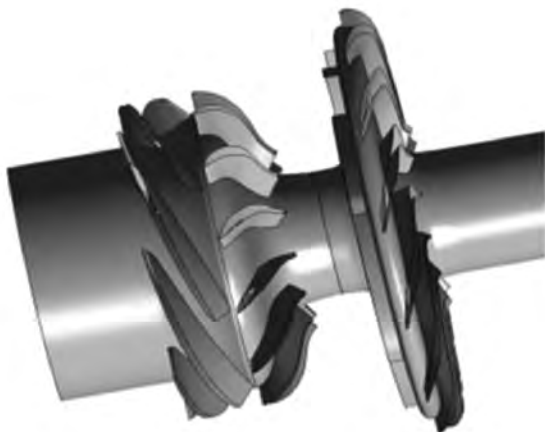

Figure 16. 3D View of Intermediate Diffuser.

The intermediate diffuser does not generate a large head. However, it has a significant influence on the next downstream impeller. The performance of the intermediate diffuser was therefore indirectly expressed by the performance of the downstream radial hydraulics.

As part of the design, full 3D fluid dynamic simulations were performed at a variety of operating conditions. The key objective for the design was to provide optimum inlet conditions for the first centrifugal stage and at the same time avoid flow instabilities over a wide range of operating conditions. Figure 17 illustrates a typical computational fluid dynamics (CFD) plot.

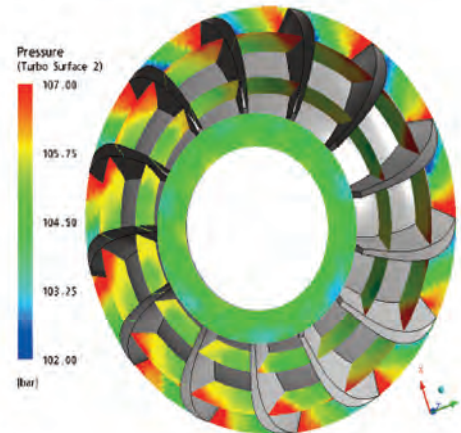

Figure 17. Plot of Intermediate Diffuser CFD Simulation.

The test pump was equipped with pressure measurements upstream and downstream of the intermediate diffuser in order to verify the hydraulic performance of this element at the variety of test conditions covered.

CONCLUSIONS

The Pazflor pump operating requirement was very demanding, beyond what is normally required either subsea or topside. Therefore, a thorough review of the existing pump technology was carried out, concluding that the only solution was to develop and qualify a new type of pump, the so-called “hybrid pump.”

The hybrid pump prototype (2H+2R) went successfully through a very comprehensive qualification program, running with viscous model oil to be as representative as possible to the real Pazflor process condition. Results showed that:

- The performance curves were well predictable and stable, and very tolerant to the gas content (with two helicoaxial stages, no capacity reduction as long as GVF < 30 percent).
- Performance of the helicoaxial stages deviated somewhat from predicted performance depending on fluid conditions. In general, the hydraulics did overperform compared to estimates, most likely due to reduced effective viscosity at two-phase conditions.
- The rotordynamic behavior of the rotor was trouble-free, as predicted by the rotordynamic analysis. Especially, no instability was observed through the balance piston, even at 250 cP and 14 percent GVF at the piston inlet.
- Pump performance losses are mainly driven by density and viscosity, which can be compensated for by increasing the pump speed (+7 percent for 250 cP).

The pump performances were confirmed one year later (June 2008) during the tests of the first “full-scale” Pazflor pump (2H+6R). The tests confirmed the results obtained with the (2H+2R) pump prototype, showing that the effect of the additional four radial stages was to reduce the steepness of the pump performance curve. This was indeed just as expected (Figure 18).



Figure 18. View of the First Pazflor Hybrid Pump on the Test Stand.

NOMENCLATURE

GVF	= Gas volume fraction
BEP	= Best efficiency point
WC	= Water cut
C_Q	= Flow correction factor
C_H	= Head correction factor
C_η	= Efficiency correction factor