

HEAT TRANSFER IN MECHANICAL SEALS

by

Gordon S. Buck

Senior Mechanical Engineer

John Crane Inc.

Baton Rouge, Louisiana



Gordon S. Buck has a B.S. degree in Mechanical Engineering from Mississippi State University (1970) and an MS in mechanical engineering from Louisiana State University (1978). He has held various engineering positions with Gulf Oil, Eastman Kodak and Exxon in the chemical and refining industries. He was Regional Sales Manager for United Centrifugal Pump Company, and is currently Senior Mechanical Engineer for John

Crane Inc.

Mr. Buck has written several technical publications, including two books.

ABSTRACT

Numerous studies have shown that mechanical seal reliability is related to the state of the fluid between the seal faces. In turn, the fluid state depends on the seal face temperature. Unfortunately, calculating the seal face temperature has required complex and time consuming calculations such as the finite element method. A method of estimating the seal face temperature is presented. A closed form analytical solution which considers both convective and conductive heat transfer is given for a simple rectangular seal shape. A heat transfer "efficiency" is defined for this simple shape and presented in chart form. Efficiencies are also presented for more complex seal shapes. The charts are used in examples to calculate seal face temperatures for several configurations and services.

INTRODUCTION

A mechanical seal is a device used to prevent leakage around a shaft; one of the more common applications of a mechanical seal is in a centrifugal pump. A typical mechanical seal is shown in Figure 1. In Figure 1, heat is generated as the primary ring rubs against the mating ring during pump operation.

To assure reliable operation, mechanical seal manufacturers recommend maintaining a cool, clean, lubricating liquid environment around the seal. Hughes [1] showed that the combination of a pressure drop and temperature increase can cause the liquid to vaporize between the seal faces. Buck [2] showed that seal reliability was related to the relative proportions of liquid and vapor between the seal faces. Buck [3] presented a method of estimating the relative amounts of liquid and vapor between the seal faces. Buck's method is strongly dependent on the seal face temperature. Will [4] presented an example of improving reliability by reducing the face temperature.

Hughes, et al. [1], estimated the face temperature for semi-infinite solid seal shapes. Although this approximation illustrates the importance of thermal conductivity, it is not useful for comparing different seal shapes made of similar materials. Buck

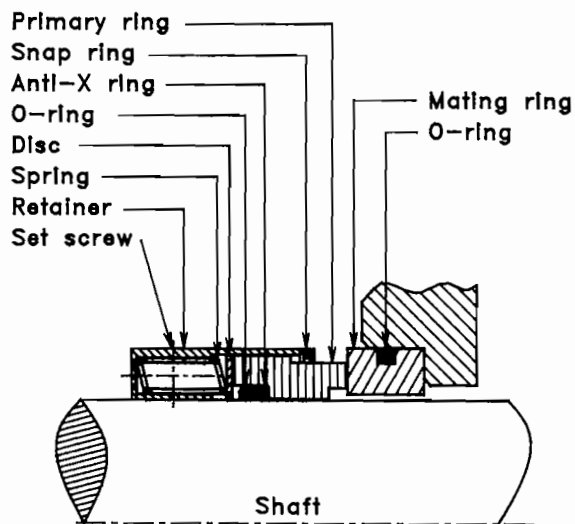

Figure 1. Typical Mechanical Seal.

[2] assumed a linear temperature distribution based on inspection of the seal shape. Will [4] assumed face temperatures based on experimental data from a small sample of shapes. Lebeck [5] used a finite difference method to determine the temperature distribution for a particular seal shape.

The purpose herein is to present a simplified method of estimating seal face temperatures. The proposed method considers conduction, convection and seal shape.

ONE DIMENSIONAL HEAT TRANSFER MODEL

The heat transfer process in a mechanical seal is illustrated in Figure 2. Heat is generated as the primary ring rubs against the mating ring. This heat must pass through those rings and into the surrounding fluid. Obviously, both conduction and convection mechanisms must be considered.

Because the sealing elements are physically small, there is a certain temptation to consider each element as a lumped mass (that is, at a uniform temperature). This approximation leads to very low estimates of the temperature at the seal faces and is not recommended.

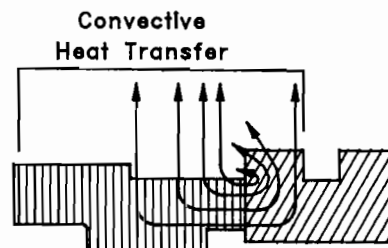

Figure 2. Heat Transfer Paths.

A more realistic approximation than the lumped mass approach considers the primary ring and the mating ring as separate elements. The individual elements may then be analyzed as one dimensional fins. The fin is considered to have a heat flux at the base (seal face) and an insulated end. Because this is a one dimensional analysis, the temperature is considered to vary only along the length of the seal. This approach is illustrated in Figure 3 and recommended in a 1988 publication [7]. The heat transfer rate through such a fin is (using the classical arrangement of the Holman [8] variables)

$$q = \sqrt{hCkA} \Delta T \tanh(mL) \quad (1)$$

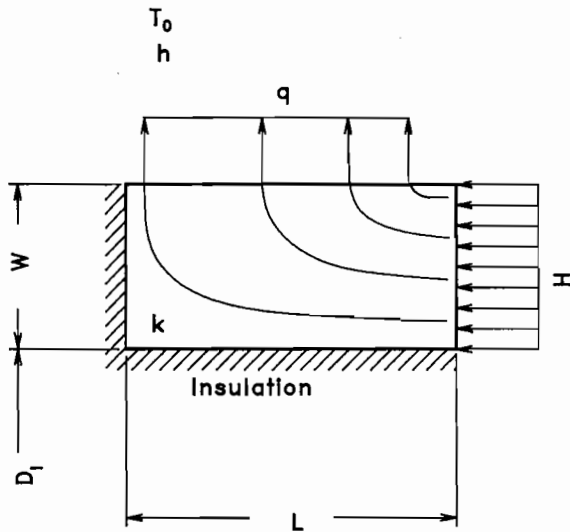

Figure 3. Representing a Seal by a Fin.

In the classical approach to a study of heat transfer from a fin, the fin efficiency is defined by

$$\text{Fin efficiency} = \frac{\text{actual heat transferred}}{\text{heat which would be transferred if entire fin area were at base temperature}}$$

For the fin in Figure 3, the efficiency becomes

$$e = \frac{\tanh(mL)}{mL} \quad (2)$$

For a seal shape, mL can be arranged as

$$mL = \frac{L}{W} \sqrt{\frac{hW}{k}} \quad (3)$$

The efficiency of a fin/seal varies with length, width, thermal conductivity and convection coefficient as shown in Figure 4. For a seal, according to data presented in Figure 4, the lumped mass approach ($e = 1$) would only be valid at low values of mL. For example, this would be true with extremely high thermal conductivity and/or very low convection coefficients.

The advantage of working with efficiency is that it may be determined for a mechanical seal (for example, by experiment) and then applied to the simple relationship shown in Equation (4).

$$q = e h A_h (T_f - T_0) \quad (4)$$

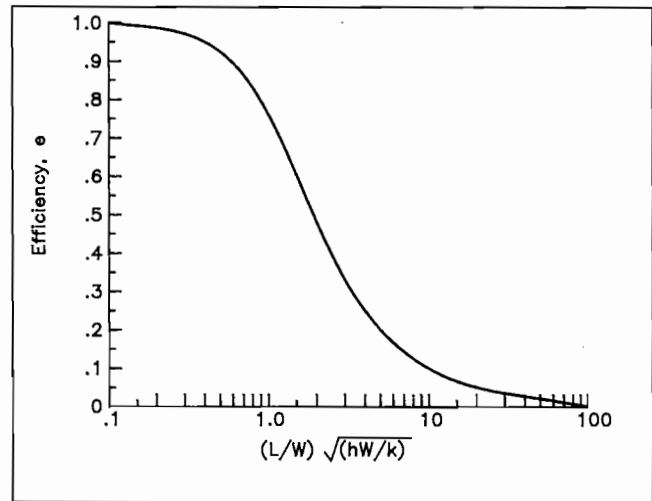

Figure 4. Efficiency of a One Dimensional Fin.

TWO DIMENSIONAL HEAT TRANSFER MODELS

Although the actual magnitude of the gradient may be small, realistically, the temperature must vary across the seal faces. For the majority of single, inside mounted seals, the face temperature should be at a maximum near the inside diameter and a minimum near the outside diameter. For a two dimensional model, the mathematics are more complex than for a one dimensional model; however, a closed form analytical solution can be developed for a simple shape (see Appendix B). This two dimensional model may be used to estimate the efficiency of a simple seal shape using Equation (5) as the definition for the mechanical seal heat transfer efficiency, E, based on the average face temperature, T_a .

$$E = \frac{q}{h A_h (T_a - T_0)} \quad (5)$$

The way the efficiency of a simple seal shape varies with the length/width ratio, L/W is shown in Figure 5. As might be expected, the efficiency of a seal shape, E, approaches the efficiency of a fin, e, for large values of L/W .

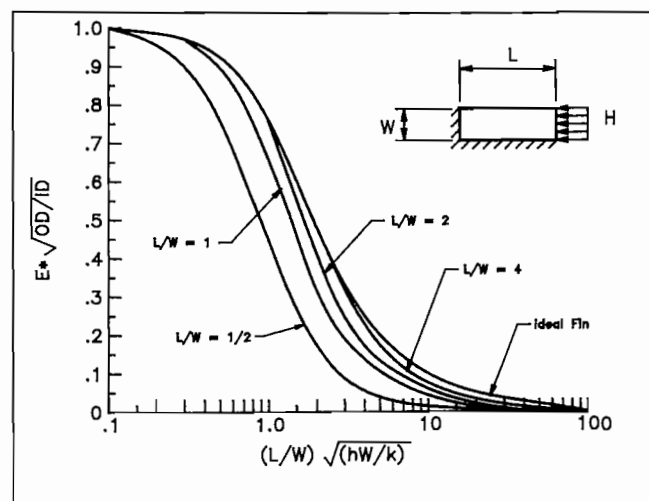

Figure 5. Heat Transfer Efficiency of a Seal.

An example is shown in Figure 6 of the temperature distribution in a two dimensional representation of a simple seal shape. This example illustrates how rapidly the temperature decreases with distance from the face.

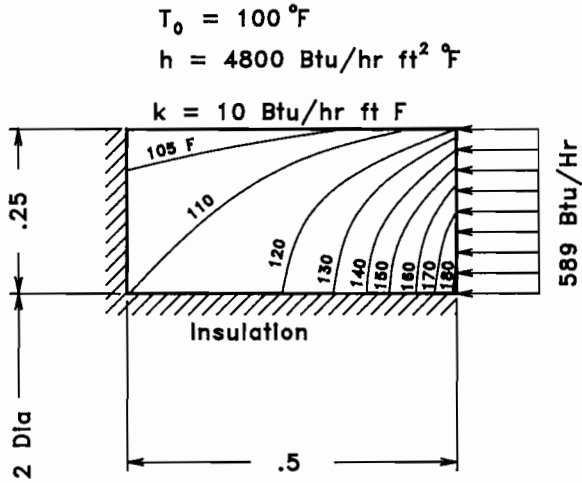

Figure 6. Example of Temperature Distribution.

All of the previous discussion has assumed that the heat transfer characteristics of a primary ring and mating ring can be approximated by a simple rectangular solid. Most commercially available seals incorporate various changes in cross section into the design. A typical example is shown in Figure 1. In order to consider these effects, the Lebeck, et al., study was used to develop heat transfer efficiencies for the shape variations shown in Figure 7.

Shape 1 in Figure 7 is a simple rectangular solid which can be analyzed using Appendix B. The heat flux is applied uniformly over the seal face width, W. The inside diameter and the end opposite the seal face are insulated. Heat transfer efficiencies for Shape 1 are presented in Figure 5.

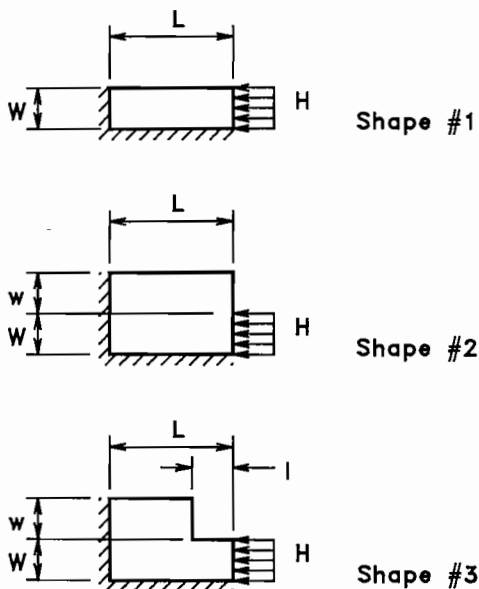

Figure 7. Seal Shapes.

Also in Figure 7, Shape 2 represents a seal shape with an outside diameter greater than the face width, W. This is representative of the mating ring in Figure 1. The heat flux is applied uniformly over the face width, W. Heat transfer efficiencies for Shape 2 (with $w = W$) are shown in Figure 8. It is useful to consider that Shape 2 is constructed from Shape 1 by adding a "shell" of width w to the outer diameter. Although this shell increases the convective heat transfer area, A_h , it also increases the conductive heat transfer resistance because of the added material. The net effect is a decrease in heat transfer efficiency as compared to Shape 1. Interpolation can be done between Figures 8 and 5 by realizing that Figure 5 is for $w = 0$.

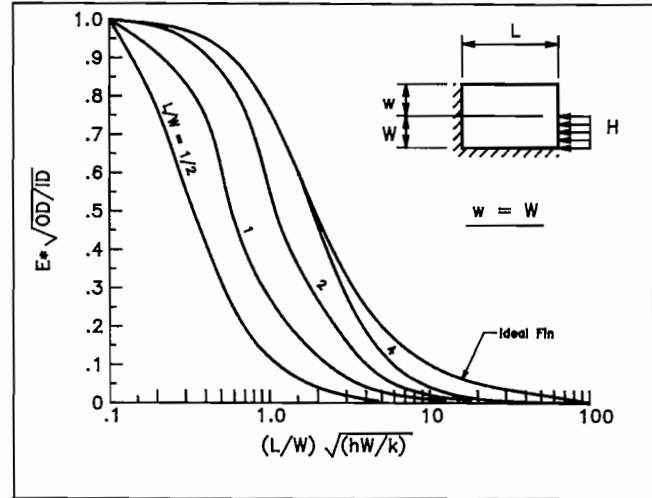

Figure 8. Heat Transfer Efficiency.

In the same manner, Shape 3 is constructed from Shape 2 by removing a portion of the "shell", w, near the seal face. Therefore, it is reasonable to expect efficiencies for Shape 3 to be greater than Shape 2 but less than Shape 1. Efficiencies for Shape 3 are shown in Figure 9 for $l = w = W$. Interpolation can be done between Figure 9 and Figure 8 by realizing that Figure 8 can be considered to represent Shape 3 for $l = 0$ and $w = W$. Similarly, Figure 5 represents Shape 3 for $l = 0$ and $w = 0$.

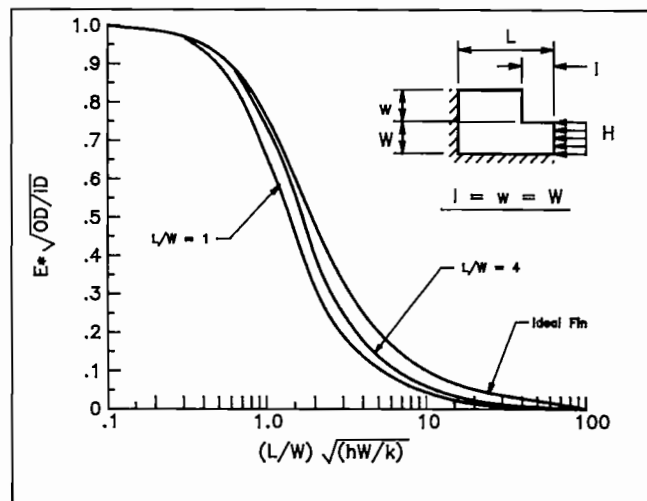

Figure 9. Heat Transfer Efficiency.

In Figures 5, 8, and 9, the effects of curvature are approximated by the including the ratio $\sqrt{D_o/D_1}$ in the dependent parameter.

When using Figure 5, 8, and 9 to represent seal shapes, the length parameter, L , should be the axial length of the wetted area for convective heat transfer. The width parameter, W , is the width of the heat flux which is the same as the seal face width.

Interpolation between Figures 5, 8, and 9 must be done with care and an appreciation for the heat transfer process. For example, when $L/W \gg 4$, the efficiency is essentially the same as for a fin. This is particularly true when $w < W$. Also, for shapes similar to Shape 3, the efficiency is essentially the same as Shape 1 if $l > W$.

COMBINING SHAPES

As shown in Figure 1, a complete seal contains a primary ring and a mating ring. The primary ring and mating ring will typically be made from different materials and have different shapes. For example, the primary ring of Figure 1 is typically carbon with $L/W > 3$. It is best represented by Shape 1. The mating ring in Figure 1 is typically tungsten carbide (or silicon carbide) with $L/W = 1$. It is best represented by Shape 2 with $w < W$.

To consider the combined heat transfer process for the primary and mating rings, let

$$\begin{aligned} q_1 &= E_1 h_1 A_{h1} \Delta T_1 \\ q_2 &= E_2 h_2 A_{h2} \Delta T_2 \end{aligned} \quad (6)$$

Assuming that all heat generated is transferred through the primary and mating rings and into the surrounding liquid, the total heat transfer is

$$H = q_1 + q_2 \quad (7)$$

Because the majority of the heat transfer occurs near the face, it is convenient to assume

$$h_1 = h_2 = h \quad (8)$$

Also, since the primary ring and mating ring are in contact, their face temperatures are assumed to be equal, therefore

$$\overline{\Delta T}_1 = \overline{\Delta T}_2 = \overline{\Delta T} \quad (9)$$

With these assumptions, the heat transfer process is given by

$$H = h(E_1 A_{h1} + E_2 A_{h2}) \overline{\Delta T} \quad (10)$$

and

$$\begin{aligned} q_1 &= \frac{E_1 A_{h1}}{E_1 A_{h1} + E_2 A_{h2}} H \\ q_2 &= \frac{E_2 A_{h2}}{E_1 A_{h1} + E_2 A_{h2}} H \end{aligned} \quad (11)$$

Implicit in the previous assumptions is that the heat transfer efficiency of the combined shapes is independent of the combination. As with the other assumptions, this is only an approximation. The extent of error this introduces will be illustrated in the examples.

ESTIMATING THE FACE TEMPERATURE

The basis of a procedure for estimating the face temperature has now been established. The method is summarized as follows:

- Calculate the total heat load using a consistent method such as shown in Appendix A.

- Estimate the efficiency for the separate primary and mating rings using Figures 5, 8 and 9.
- Calculate the average face temperature using Equation (10).

Several examples follow.

EXAMPLE 1

Estimate the average face temperature for the seal shape shown in Figure 6. The heat load is specified as 589 Btu/hr.

This is a simple example of Shape 1 with $L/W = 2$.

$$\frac{hW}{k} = \frac{4800(.25/12)}{10} = 10$$

$$A_h = \pi (2.5) .5 = 3.93 \text{ in}^2$$

From Figure 5, $E \sqrt{OD/ID} = .1$, yielding $E = .089$.

Transposing Equation (10), the average differential temperature is

$$\overline{\Delta T} = \frac{589(144)}{4800(0.089)(3.93)} = 50.5 \text{ F}$$

If the length were increased to 1 in, then $L/W = 4$ and $A_h = 7.85 \text{ in}^2$. Then from Figure 5, $E = 0.05$ for the revised shape and $\Delta T = 50 \text{ F}$. This illustrates the minimal effects of increasing the length when $L/W > 2$.

EXAMPLE 2

Estimate the face temperature for a seal using a primary ring/mating ring pair similar to Figure 1. Dimensions are shown in Figure 10. The heat generation is $H = 1500 \text{ Btu/hr}$ and the convective film coefficient is $h = 4000 \text{ Btu/hr ft}^2 \text{ F}$.

First, consider the primary ring shown in Figure 10. The face width is $1/4$ inch, but what is the representative length? The primary ring is partially enclosed by a stainless steel retainer with holes to promote circulation. This retainer is thin and its thermal conductivity is greater than that of the carbon primary ring. For these reasons, it seems reasonable to use $L = 1.0$ in. The $2\frac{3}{4}$ in maximum OD is greater than the face OD, so Shape 3 would appear to apply. A comparison with Shape 3 shows $l = 1/2$ in, which is twice the face width and $w = 1/16$ inch which is one fourth the face width. Considering l and w , it seems appropriate to represent the primary ring by Shape 1 using $L/W = 4$.

For the primary ring,

$$\frac{hW}{k} = \frac{4000(0.25/12)}{5} = 16.7$$

Using Figure 5, $E \sqrt{OD/ID} = 0.03$ yielding $E_1 = 0.027$. The convective heat transfer area is

$$A_h = \pi (2.625) 1.0 = 8.25 \text{ in}^2$$

Notice that no "credit" is allowed for the heat transfer area from the $2\frac{3}{4}$ in diameter to the $2\frac{5}{8}$ in diameter. This is because Shape 1 is being used to approximate the primary ring and Shape 1 has no steps.

Next, consider the mating ring to be represented by Shape 2. The width, W , is always the face width, so $W = 1/4$ in. A comparison of Figure 10 to Shape 2 shows $w = 0.5(2.75 - 2.625) = 0.0625$ in yielding $w/W = 0.25$. The representative length, L , for this mating ring is not $5/8$ in because the O-ring (Figure 1) limits liquid contact to the $1/4$ in length section. Therefore, a representative length $L = 1/4$ in will be used and $L/W = 1$.

The thermal conductivity of the mating ring is different from the primary ring. For the mating ring

$$\frac{hW}{k} = \frac{4000(0.25/12)}{15} = 5.6$$

Using Figure 8 for $L/W = 1$, read $E\sqrt{OD/ID} = 0.12$ for $w = W$. From Figure 5 for $L/W = 1$ and $w = 0$, read $E\sqrt{OD/ID} = 0.27$. Interpolate to get $E\sqrt{OD/ID} = 0.23$ for $w = W/4$. Therefore, $E_2 = 0.21$.

The convective heat transfer area of the mating ring is

$$A_{h2} = \pi(2.75)0.25 + \pi(2.75^2 - 2.625^2)/4 = 2.69$$

The average face temperature rise above the surrounding liquid can now be estimated using Equation (10) as

$$\overline{\Delta T} = \frac{1500(144)}{4000[0.027(8.25) + 0.21(2.69)]} = 69^\circ\text{F}$$

For this seal, if the mating ring were changed to tungsten carbide with a thermal conductivity $k = 50$ Btu/hr ft²F, then

$$\frac{hW}{k} = 1.67$$

and E_2 (for $w = W/4$) = 0.4 yielding $\Delta T = 41^\circ\text{F}$.

A complete finite difference analysis of this seal [10] yields $\Delta T = 68^\circ\text{F}$ with a ceramic mating ring and 40°F with a tungsten carbide mating ring. (In the finite element analysis, the effect of the retainer was neglected. The complete mating ring was considered with convection limited to the wetted area.)

EXAMPLE 3

Suppose that the primary ring and mating ring of a 2.0 in balanced seal can each be represented by Shape 1. The dimensions are

	Primary Ring	Mating Ring
OD, inch	2.363	2.363
ID, inch	1.863	1.863
Length, inch	1.0	0.25
Conductivity, Btu/hr ft F	5	50
Balance ratio	75%	
Unit spring load	30 psi	

Evaluate this seal for the following service in a centrifugal pump

Liquid: Propane
 Temperature: 100°F
 Vapor pressure: 190 psia
 Specific gravity: .48
 Suction pressure: 200 psia
 Discharge pressure: 300 psia
 Stuffing box pressure: 225 psia
 Saturation temperature at 225 psia: 112°F
 RPM: 3600

Assume that the following applies for this application:

Coefficient of friction: $f = 0.1$

Convective heat transfer coefficient: $h = 2000$ Btu/hr ft²F

Pressure gradient factor: $k_g = 0.72$

This application meets the API requirement that stuffing box pressure be at least 25 psi above suction pressure. Also, the suction pressure is sufficiently high to produce 48 feet of Net Positive Suction Head (NPSH).

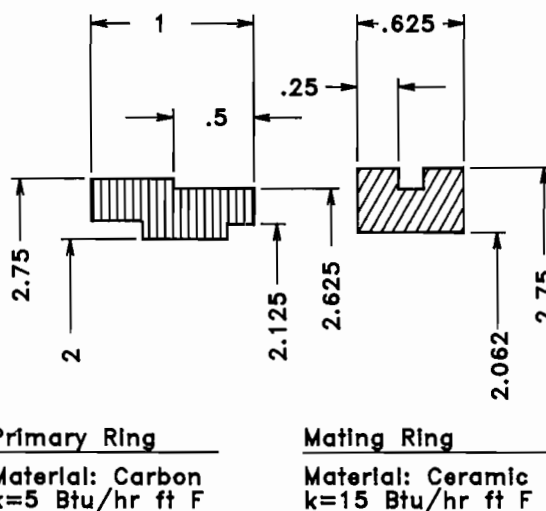

Figure 10. Seal for Example 2.

Because the vapor pressure is greater than atmospheric, flashing will occur between the faces even if there is no heat generation. (The interface is a maximum of 58 percent liquid, even if there is no heat generation [3].)

Using Appendix A, the total heat load is 930 Btu/hr.

For the primary ring

$$\frac{hw}{k} = \frac{2000(0.25/12)}{5} = 8.33$$

$$A_h = \pi(2.363)1 = 7.42 \text{ in}^2$$

$$L/W = 4$$

$$OD/ID = 1.27$$

Using Figure 5, $E_1 = 0.08$.

For the mating ring

$$\frac{hw}{k} = \frac{2000(0.25/12)}{50} = 0.833$$

$$A_h = \pi(2.363)0.25 = 1.86 \text{ in}^2$$

$$L/W = 1$$

$$OD/ID = 1.27$$

Using Figure 5, $E_2 = 0.63$.

From Equation (10)

$$\overline{\Delta T} = \frac{930(144)}{2000[0.08(7.42) + 0.63(1.86)]} = 38^\circ\text{F}$$

Therefore, the expected average face temperature is 138°F. This is above the saturation temperature (112°F) for the stuffing box pressure (225 psia). This seal would operate as a gas phase seal with low reliability. Will [4] discusses a similar example where reliability was improved by increasing the balance ratio while decreasing the face width to reduce heat generation.

SUMMARY

Because mechanical seal reliability is related to the seal face temperature, a comprehensive method of estimating temperature will permit selection of more reliable seals. A simplified, but reasonably accurate, method was presented.

The proposed method considers the shape and thermal conductivity of the primary ring and mating ring as well as con-

vective heat transfer and heat generation. The computational procedure is straight forward, relying on simple equations supplemented by "heat transfer efficiencies" from charts.

Charts of heat transfer efficiencies were presented for three shapes which are representative of commercially available seals. More specific charts could be prepared by using finite element analysis or experimental data for a particular seal.

CONCLUSIONS

Although the primary purpose of this report was to present the computational method, the following conclusions were reached:

- The vast majority of the heat transfer process takes place within a distance of approximately two face widths on either side of the sealing interface.

- The majority of the heat transferred is through the element with the greater thermal conductivity if that element has sufficient wetted area for convective heat transfer.

- Thermal conductivity and convective heat transfer coefficient are the two most important parameters relating to face temperature. Existing data for convection around a mechanical seal is very limited and not consistent.

- For a given heat load, seals with "narrow" faces have lower face temperature than seals with "wide" faces. (In addition, seals with narrow faces generate less heat.)

Those who use this method for estimating seal face temperatures will find that the following features will be preferred:

- Narrow faces
- Material pairs with low friction coefficients such as carbon/tungsten carbide and carbon/silicon carbide.
- Materials with good thermal conductivity such as tungsten carbide and silicon carbide.
- Low balance ratios. A word of caution: *Although seals with low balance ratios produce less heat they also may become unstable under certain conditions. This aspect of seal design is discussed in detail in the literature [2,3,4,5].*
- A "wetted" area at least equal to twice the seal face area for each component.

FURTHER WORK

Although this procedure may be viewed as somewhat simplistic, the real limitation on applying it is the lack of convective heat transfer data. Without such data, even the most exacting finite element analysis is futile.

APPENDIX A

The following relationships are taken from Schoenherr [6]:

The heat generation by a seal is given by Equation (A1)

$$H = P_f V A_f f \quad (A1)$$

where

$$P_f = \Delta P (b - k_g) + P_{sp} \quad (A2)$$

For parallel faces, $k_g = 0.5$ for a liquid interface and 0.67 for a vapor interface. For a mixed interface, k_g will be greater than 0.67. Values as high as $k_g = 0.9$ are reported [3]. The complete range for k_g is between 0 and 1.

The mean face velocity, V , is

$$V = \pi D_m N$$

The friction coefficient, f , varies with material combinations and liquid. Values between 0.03 and 0.3 are generally reported.

APPENDIX B

For the simple rectangle shown in Figure B1, the temperature distribution may be determined as follows:

For steady state heat transfer, the Laplace equation applies.

$$\frac{d^2\theta}{dx^2} + \frac{d^2\theta}{dy^2} = 0 \quad (B1)$$

The boundary conditions which apply to Figure B1 are

$$\frac{d\theta}{dx} = 0 \quad \text{at } x = 0 \quad (B2)$$

$$\frac{d\theta}{dx} = \frac{q}{k} \quad \text{at } x = L \quad (B3)$$

$$\frac{d\theta}{dy} = 0 \quad \text{at } y = 0 \quad (B4)$$

$$\frac{d\theta}{dy} = -\frac{h}{k} \theta \quad \text{at } y = W \quad (B5)$$

As shown by Arpaci [9], the classical separation of variables technique combined with the principal of orthogonality may be used to solve this set of equations, resulting in

$$\theta_{(x,y)} = \sum_{n=1}^{\infty} B_n \cosh(\lambda_n x) \cos(\lambda_n y) \quad (B6)$$

where

$$B_n = \frac{2 q L \sinh(\lambda_n W)}{k \lambda_n \sinh(\lambda_n L) [\lambda_n W + \sinh(\lambda_n W) \cos(\lambda_n W)]} \quad (B7)$$

with

$$\lambda_n W \tan(\lambda_n W) = \frac{hW}{k} \quad (B8)$$

NOMENCLATURE

A_f	Seal face area
A_h	Heat transfer area for convection
b	Geometric balance ratio
C	Circumference
D	Face diameter
E	Heat transfer efficiency
e	Theoretical fin efficiency for heat transfer
f	Coefficient of friction
H	Heat generation rate for the seal
h	Average convective heat transfer coefficient
k	Thermal conductivity
k_g	Pressure gradient factor
L	Total seal length
l	Length of a diameter change near the seal face
N	Shaft speed
P	Pressure
P_{sp}	Unit spring load on the seal face
ΔP	Pressure differential = $P_1 - P_2$
q	Heat transfer rate for the seal
R	Seal face radius
T	Temperature
T_0	Bulk temperature of the liquid
T_a	Average seal face temperature = $(T_{od} + T_{id})/2$
ΔT	Differential temperature = $T_a - T_0$
w	Width of a diameter change or offset near the face
V	Mean peripheral velocity at the seal faces
θ	Differential temperature = $T_a - T_0$

Subscripts

1	Sealing element #1 (the primary ring)
2	Sealing element #2 (the mating ring)
f	Seal face
i	Seal face inside diameter
o	Seal face outside diameter

REFERENCES

- Hughes, W. F., Winowich, N. S., Birchak, M. J., and Kennedy, W. C., "Phase Change in Liquid Face Seals," *Journal of Lubrication Technology*, 100, pp. 74-79 (1978).
- Buck, G. S., "A Methodology for Design and Application of Mechanical Seals," American Society of Lubrication Engineers, 34th Annual Meeting (1979).
- Buck, G. S., "The Flashing Index as a Measure of Mechanical Seal Reliability," *STLE* (1989).
- Will, T. P., "A Powerful Application and Troubleshooting Method for Mechanical Seals," *Proceedings of the Second International Pump Symposium*, Turbomachinery Laboratory, Department of Mechanical Engineering, Texas A&M University, College Station, Texas (1985).
- Lebeck, A. O., "Face Seal Balance Ratio Selection for Two Phase Single and Multicomponent Mixtures," *Proceedings of the Fifth International Pump Users Symposium*, Turbomachinery Laboratory, Department of Mechanical Engineering, Texas A&M University, College Station, Texas (1988).
- Schoenherr, K. S., "Design Terminology for Mechanical End Face Seals," Society of Automotive Engineers, Paper Number 650301 (1965).
- Summers-Smith, Ed., *Mechanical Seal Practice for Improved Performance*, London: Mechanical Engineering Publications, Limited (1988).
- Holman, J. P., *Heat Transfer*, 3rd Edition, New York: McGraw-Hill (1972).
- Arpaci, V. S., *Conduction Heat Transfer*, Reading, Massachusetts: Addison-Wesley Publishing Company (1966).
- Lebeck, A. O., Young, L. A., Hong, Y. M., Kanas, P., and Sampayan, K., "Application of Wavy Mechanical Face Seal to Submarine Seal Design," Summary Report ME-129 (84) ONR-233-1, Prepared for Office of Naval Resource, ONR-N-00014-83-K-0-304, The University of New Mexico, Department of Mechanical Engineering (1984).
- Engineering Data Book, Volume II*, Tenth Edition, Tulsa, Oklahoma: Gas Processors Association (1987).

ACKNOWLEDGEMENTS

I especially appreciate the assistance and encouragement given by Dr. A. O. Lebeck. Also, this work would not have been possible without the support of John Crane Inc.