

# DESIGN, CONSTRUCTION, AND APPLICATIONS OF MAGNETICALLY COUPLED CENTRIFUGAL PUMPS

by

Harry J. Schommer

Chief Engineer

Dickow Pumpen KG

Waldkraiburg, West Germany

and

Tom Johnson

General Manager

Dickow Pump Company

Marietta, Georgia



*Harry J. Schommer is Chief Engineer of Dickow Pumpen KG in Waldkraiburg, West Germany. He is responsible for the development and design of the manufacturing program for Dickow Sealless magnetic driven pumps. His goal was the development of a maintenance free, zero leakage pump design that meets the customer's requirements and the environmental laws regarding pump leakages. He has been in the pump business since*

*1959, and joined Dickow in 1963, as Design Engineer. He has authored several papers on pumps and shaft sealing systems and conducted several seminars for pump users in West Germany, Europe and the Far East.*

*Harry J. Schommer is a member of the VDI (Verein Deutscher Ingenieure) and registered at the Bavarian Government as a Professional Engineer.*



*Tom Johnson has been involved in the application of process and API pumps for twenty one years. He was the National Distributor Manager for Dean Brothers Pumps and, since 1986, has been General Manager of Dickow Pump Company USA, dealing only with the application of magnetically coupled centrifugal pumps. Mr. Johnson has held sealless pump design seminars throughout North America during his tenure with Dickow. He attended both Columbia University and the University of Pittsburgh.*

*He attended both Columbia University and the University of Pittsburgh.*

## ABSTRACT

Since the early 1970s, environmental protection has become more and more important when designing industrial plants and, today, this question is always first in any public discussion. Thus, the engineering profession ought to face the problems of environmental protection, and offer solutions in order to key pollution to a bare minimum. In this regard, attention should also be paid to environmental laws which are becoming increasingly restrictive with regard to leakage. Examples are the aggravated in-

junctions by government rules in West Germany and California, concerning the design of pumps, respectively, of the shaft seals when transporting hydrocarbons, especially for fluorine chloride hydrocarbon liquids, as methylene chloride, trichlorethylene and perchlorethylene.

In view of environmental pollution, the weakest link of centrifugal pumps is the shaft sealing, because mechanical seals always have some level of leakage. The average leakage rate of a mechanical seal is 3.0 to 8.0 cm<sup>3</sup>/h. This value may seem very low at first. However, considering the big chemical processing plants having thousands of pumps in operation, the atmosphere penetration leakage rate grows remarkably. Problems are caused by formation of dangerous explosive mixtures and those problems increase when toxic or bad smelling gases and vapors penetrate and endanger maintenance personnel.

In order to avoid evaporation of the fluid film between the mechanical seal faces, additional cooling is required when handling products with a vapor pressure above the atmosphere pressure at operating temperature. When handling products which recrystallize in the atmosphere, a suitable quench connection must be provided. Such auxiliary seal devices should be provided with additional fittings and checking equipment. The affected liquid must be refined and treated.

Past efforts have been made for improving the performance of mechanical seals and meeting these requirements. An example of this is the double acting mechanical seal of "tandem-design" and of "back-to-back-design" with the relevant auxiliary equipment. But, it appears that mechanical seals in conventional industrial pumps have nearly reached their developmental limits for increased reliability and lower leakage.

Sealless pumps are the only pumps with zero leakage, because they have no seals.

## INTRODUCTION

The earliest development of sealless pumps was the canned motor pump with its generally known principle and design. Apart from the canned motor pumps, sealless pumps with magnetic couplings were also built in the past, but the ferrite and alnico-magnets available at that time had many disadvantages compared to the canned motor pump. For example:

- demagnetization of the coupling if the rotating pump unit slips, gets overloaded or blocked
- requirement of large magnet mass for driving power transmission
- poor efficiency through magnet losses up to 15 to 20 percent of the driving power.

However, in the last few years, the development of permanent magnets of rare earths/cobalt offer remarkable benefits regarding reliability and economy. For example: samarium-cobalt coupling requires only six percent of the mass of a ferrite coupling for transmitting a certain torque. The magnet loss of a coupling transmitting a torque of 51 Nm is 700 g, when used coupling material is samarium cobalt. The weight of a comparable ferrite coupling is approximately 12300 g.

It was now possible to construct a centrifugal pump, hermetically sealed without any atmospheric shaft duct, driven via permanent magnet and a minimum space requirement. The different constructional volumes of the available magnet materials of same torque are shown in Figure 1. Due to the compact construction, the magnet losses were also reduced, so that coupling efficiencies of >90 percent can be obtained.

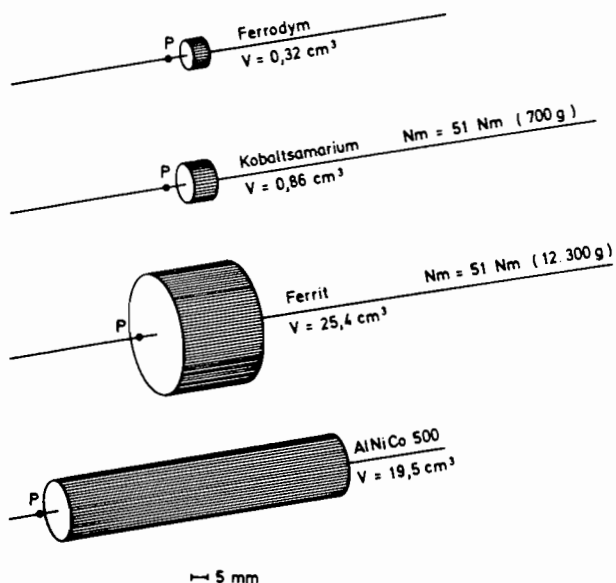

Figure 1. Volume Comparison of Magnet Materials.

Pumps with compact permanent magnet couplings can be driven by a standard motor with direct online starting. Magnetic drive centrifugal pumps do not count as electrical equipment and therefore can also be employed with standard ex-motors in explosion proof areas.

Investigations into availability and repair susceptibility of magnetically driven sealless pumps magnet drive and mechanical seals pumps, has shown in practice that the damage and failure rate of seal pumps is remarkably higher than of sealless pumps. Thus, the increased usage of magnetic driven pumps has not just a positive environmental factor, but is also a contribution to a considerable reduction of operating and maintenance expenses in chemical processing plants.

When comparing the initial costs of a conventional industrial pump, including double acting mechanical seal and auxiliary equipment in accordance to API 610, plan 52/53, with the price of a medium sized sealless magnetic driven pump the price for the sealless pump is far below the price for the seal pump.

Thus, it is expected that the use of sealless magnetically driven pumps will increase dramatically over the next decade. As the knowledge of this new technology becomes more important to the engineers in the chemical and petrochemical industry, the following section will explain the basic technology of magnetically driven centrifugal pumps and possible applications.

## CONSTRUCTIVE DESIGN MAGNETIC DRIVEN VOLUTE CASING PUMP

A typical horizontal volute casing pump is shown in Figure 2 with a magnet drive. The volute casing is connected to the magnet drive via the bearing housing. The pumped liquid is hermetically sealed from the atmosphere. The driving power is transmitted by the motor, via the outer magnet coupling, through the magnetic fields which connect the outer and inner magnets. There is no shaft duct to the atmosphere, and no shaft sealing device is required.

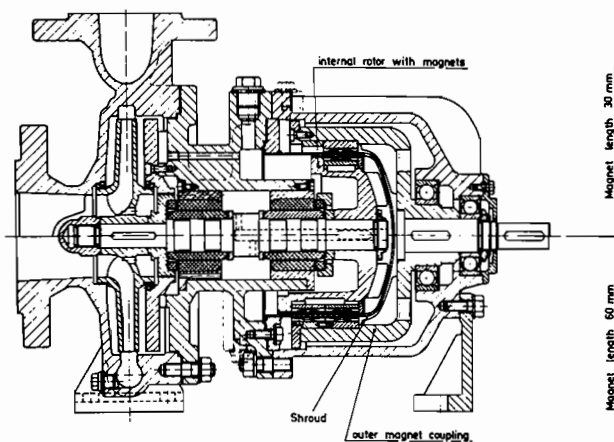

Figure 2. Horizontal Volute Casing Pump with Magnetic Drive.

The shroud is bolted to the bearing housing by self locking inbus ribbed bolts. That means, the bearing bracket, together with outer magnet coupling and antifriction bearing, can be dismantled without emptying the pump or stress relieving the system. The shrouds can be designed for operating pressure up to 600 psi maximum at 400°F. Pumps are applicable for capacities up to 3500 gpm and differential heads up to 650 ft. Maximum allowable operating temperature without cooling is 750°F. Further development regarding increased capacity and differential head is possible.

### Construction of the Magnet Coupling

The magnet coupling principle is shown in Figure 3. The single elements are stuck on the outer and the inner support ring. These rings are of cast iron that enables the formation of a closed magnetic field flux. The coupling works synchronously without slip, i.e., the motor speed is equal to the pump speed.

A stationary shroud is located between the inner and outer rotating coupling halves. The inner magnets are hermetically sealed from the pumpage. The magnet losses, as previously mentioned, are eddy current losses due to the magnet field flux, rotating with the magnets and flowing through the shroud. The shroud thickness and material determine these losses.

The transmissible power of a magnet coupling with the magnetic mass  $M$  is very much influenced by the gap between the inner and the outer magnet. That means the smaller the dimension,  $L$ , selected, the bigger is the transmissible coupling power, while the costs, depending mainly on the mass of the applied magnet material, will be the same. However, reduction of the gap at a given shroud thickness, which is determined through operating pressure and temperature, would of course impair the  $S1$  and  $S2$  clearances. The radial clearance between the inner rotor and the stationary shroud is decisive for the safety operation of the complete pump.

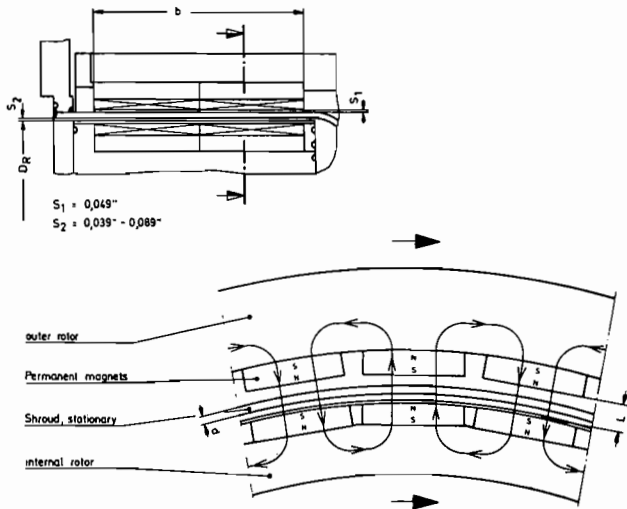

Figure 3. Magnetic Coupling Design, Magnet to Magnet Technology.

For avoidance of the rotor rubbing on the shroud and of wear through abrasive solids, the clearance  $S_2$  should be at least 1.0 mm. Smaller clearances are only acceptable when handling absolutely pure liquids. The maximum torque of chemical pumps with magnet drive is approximately 320, Nm which coincides with a rated coupling power of 120 kW at 3500 rpm.

*Internal Circulation, Partial Flow*

The eddy current losses in the metallic shroud generate heat. In order to conduct this heat and to avoid pumpage vaporizing in the shroud area, a certain flow through the gap between internal rotor and shroud is required. There are two possibilities to lead this flow through the magnet area.

*Internal Circulation from Discharge to Discharge*

A pump with internal circulation from discharge to discharge is shown in Figure 4. The circulation starts from behind the impeller and goes through the pump shaft via the back vanes on the reverse rotor side, returning to the discharge side. This enables an admission of the shroud with approximately 80 percent of the differential pressure and suction pressure. Thus, vaporization of the product through temperature rise in the magnet area is inhibited because pressure is being increased there.

The back vanes on the reverse rotor side work like a centrifugal impeller, so that the pressure  $P_5$  on the front side of the shroud is always higher than on the reverse rotor side. It must be considered that the internal rotor with the thrust bearings are floating. Shaft end play is approximately 1.0 to 1.5 mm. Due to this fact, the stationary, rotating and the floating thrust bearings work like orifices. That means, if the rotor is moved to the suction side by residual axial loads of the impeller, the gap  $S$  comes close to zero and the pressure  $P_5$  will increase (no partial flow through the bearings) until the axial loads are balanced.

Considering that the axial loads are completely balanced and that the silicon-carbide bearings are resistant against wear, abrasives and chemical attack, this type of magnetic driven pump does not need any monitoring device for shaft or bearings as they are offered along with canned motor pumps.

The temperature and pressure curve is presented in Figure 5 for a centrifugal pump of  $2 \times 1.5 \times 8.25$  in at 3500 rpm. It should be noted that the partial flow running through the magnet chamber depends only on the back vanes of the rotor and on the pump speed. That means independent from the discharge

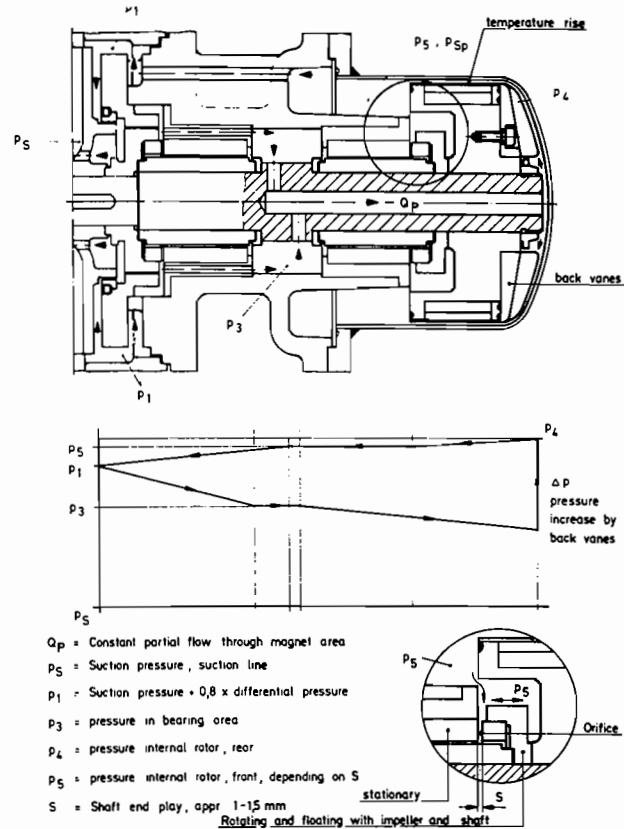

Figure 4. Internal Circulation, from Discharge to Discharge.

capacity and the differential head exists a constant circulation dissipating the heat that is generated in the shroud and leading it into the main flow in the pump casing. From the point of the minimum flow up to the point of the maximum flow, constant temperatures prevail.

When selecting sealless pumps with magnetic couplings for pumping low boiling products, the relations between shroud temperature and shroud pressure must be considered in order to exclude vaporization of the pumpage in the shroud area. If the pump is controlled by a temperature probe (Figure 6), the breaking temperature must be adjusted, so that it is below the vaporizing temperature of the liquid determined by the shroud pressure.

Another important fact about hermetically sealed pumps is that a considerable temperature rise will occur if a minimum flow is not maintained. Hence, pumps can normally not be operated against closed discharge valve. If this is a requirement due to the plant layout, a bypass must be installed from the pressure side to suction vessel.

*Internal Circulation from Discharge to Suction Side*

Another kind of magnetically driven pump design, shown in Figure 7, has internal circulation from the pump discharge to suction side, respectively, to the impeller eye. Although most of the pump manufacturers use this method of circulation, some disadvantages regarding vaporization of the product in the magnet area and NPSH conditions must be taken into account.

Circulation starts behind the impeller, goes through the gap between internal rotor and shroud, and is finally led through the impeller hub to the impeller eye. Thus, the pressure drops from  $p_1$  to  $p_s$  during flow through the pump, while the temperature of the flow rises. At the rear bearing, the pressure  $p_2$  reaches

Size 2" / 1 1/2" / 8 1/4" 3500 rpm  
Coupling 40 mm, 34 HP, P<sub>V</sub> = 2,4 HP

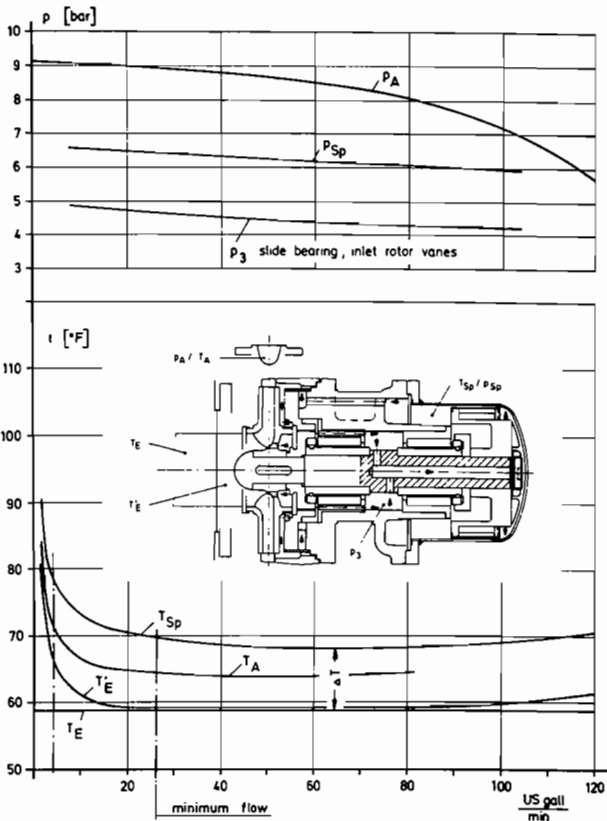

Figure 5. Internal Circulation, Pressure, Temperature Rise.

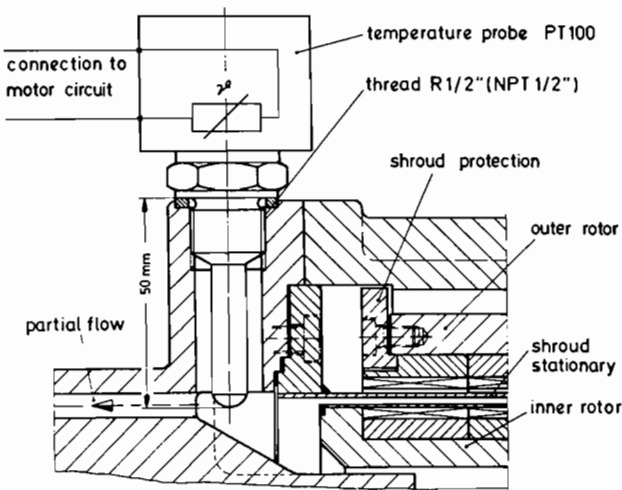

Figure 6. Thermo Probe, Internal Circulation.

nearly the suction pressure, thus, there is no meaningful safety margin against vaporization of the pumpage.

It must further be considered that the elevated temperature of the flow in the impeller eye will increase the NPSH requirement of the pump because the difference between vapor pressure of the liquid in the suction line (at temperature T<sub>E</sub>) and

vapor pressure of the liquid in the impeller eye (at temperature T<sub>E</sub>') must be added to the NPSH requirement of the pump.

This pump design can operate successfully only if the pressure on the suction side is far above the vapor pressure of the liquid (not applicable for low NPSH requirements and handling liquids at vaporizing temperature). The capacity of the partial circulating flow depends on the differential head of the pump. Thus, this flow decreases due to decreasing differential head, which can cause a considerable temperature rise, when operating the pump at maximum flow conditions right of BEP.

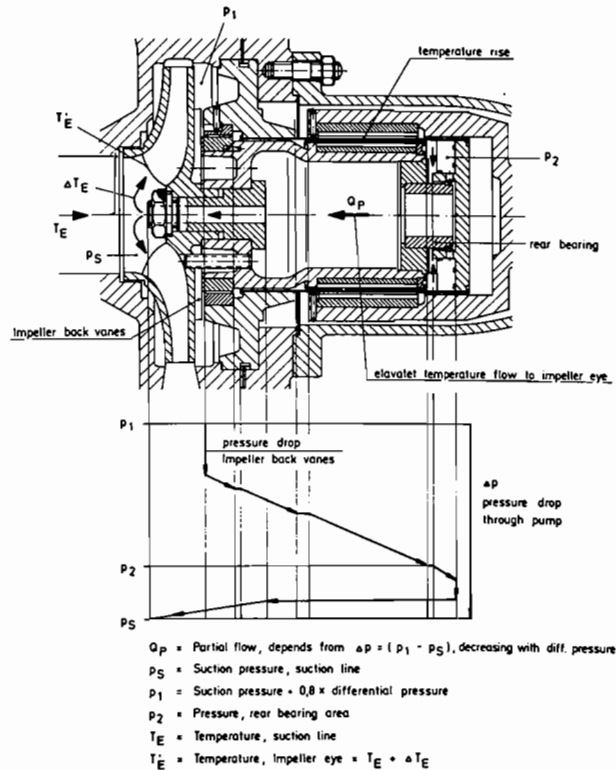

Figure 7. Internal Circulation, from Discharge to Suction Side.

**Wear Resistant Double Slide Bearings  
Silicon Carbide, SiC**

Sealless pumps require process lubricated bearings. Before silicon carbide was available, these bearings often had maintenance problems. Silicon carbide bearings work without problems in low viscosity liquids such as chemicals, hydrocarbons, solvents, acids, all kind of hydroxides, and in abrasive pumpages. The success of sealless magnetic driven pumps is based mainly on the availability of silicon carbide as bearing material.

Silicon carbide is known for its excellent resistance to erosive and chemical attack in reducing environments. However, problems are encountered in oxidizing environments, if the silicon carbide parts contain free silicon. Such parts are easily attacked by strong oxidizing chemicals. Pure SiC bearing components, containing no free silicon, provide superior chemical resistance in both reducing and oxidizing environments, with or without abrasive/erosive elements. Pure SiC-bearing components are sintered forms of alpha grade silicon carbide without any binders.

The excellent chemical resistance of pure SiC is shown in Table 1, and compared with other possible bearing materials.

Table 1. Corrosion Resistance Chart, Silicon Carbide.

Test Environment* Conc. Reagent (Wt%)	Temp.		Corrosive Weight Loss (mg/cm <sup>2</sup> yr)**			
	(°C)	(°F)	Silicon Carbide (no free SiC)	Si/SiC Composites (12 % SiC)	Tungsten Carbide (6 % Co)	Aluminium Oxide (99 %)
98% H <sub>2</sub> SO <sub>4</sub>	100	212	1,8	55,0	>1000	65,0
50% NaOH	100	212	2,5	>1000	5,0	75,0
53% HF	25	77	<0,2	7,9	8,0	20,0
85% H <sub>3</sub> PO <sub>4</sub>	100	212	<0,2	8,8	55,0	>1000
70% HNO <sub>3</sub>	100	212	<0,2	0,5	>1000	7,0
45% KOH	100	212	<0,2	>1000	3,0	60,0
25% HCl	70	158	<0,2	0,9	85,0	72,0
10% HF plus	25	77	<0,2	>1000	>1000	16,0
57% HNO <sub>3</sub>						

\* Test time:  
125 to 300 hrs of submersive testing, continuously stirred.

\*\* Corrosion Weight Loss Guide:  
1000 mg/cm<sup>2</sup>yr Completely destroyed within days.  
100 to 999 mg/cm<sup>2</sup>yr Not recommended for service greater than a month.  
50 to 100 mg/cm<sup>2</sup>yr Not recommended for service greater than one year.  
10 to 49 mg/cm<sup>2</sup>yr Caution recommended, based on the specific applic.  
0,3 to 9,9 mg/cm<sup>2</sup>yr Recommended for long term service.  
.2 mg/cm<sup>2</sup>yr Recommended for long term service; no corrosion, other than as a result of surface cleaning, was evidenced.

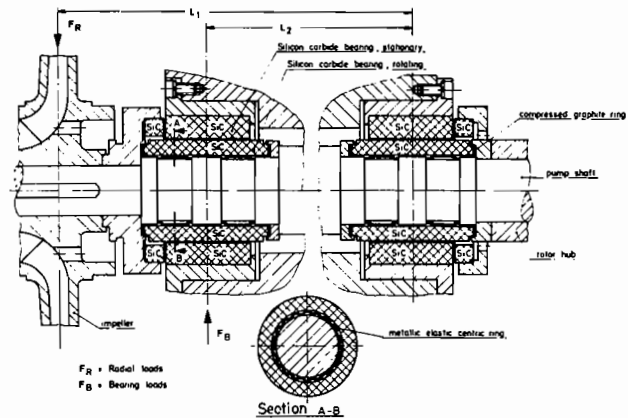

Figure 9. Design of Double Silicon Carbide Slide Bearings.

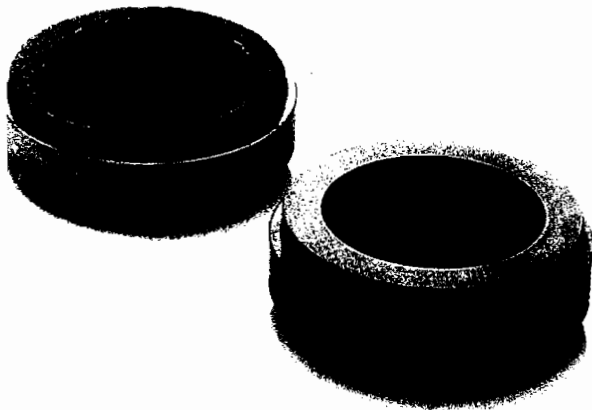

Figure 8. Two Seal Rings: a. One of tungsten carbide after 300 hours of exposure to eight percent sodium hypochloride in water, showing extreme leaching of the cobalt binder. b. One of SiC that is unaffected.

Construction of the Bearing Unit

If the axial loads of the pump impeller are properly hydraulically balanced by the pump manufacturer, the thrust bearings run wear free for the lifetime of the pump unit. The radial loads are accepted by the generously dimensioned double bearings, as shown in Figure 9.

When designing SiC bearing units, the special attributes of this material must be considered. For example, the different thermal expansion coefficients of SiC and the shaft material cause special problems in designing the connection between SiC shaft sleeve and pump shaft. A proper run requires an absolute concentricity, i.e., radial stress in the SiC shaft sleeve through thermal expansion of the shaft is inadmissible.

This problem has been solved (as per Figure 10) by locating the SiC sleeve on the shaft using elastical metallic locating rings. The axial fixation and transmission of torque is provided by compressed graphite rings.

Shroud Construction

Three possibilities are shown in Figure 11 of the shroud construction for sealless magnetically driven centrifugal pumps.



Figure 10. Pump Shaft with Internal Rotor and Shaft Sleeves.

When comparing these variants, remember that the main function of the shroud is the separation of the pumpage from the atmosphere. If the shroud is additionally used as holder for rear bearings, the weldings will be stressed by vibrations (transmitted from the impeller in case of cavitation or improper balancing) or due to misalignment between front and rear bearings. That means the shroud can work as a pressure vessel to keep the product inside the pump in the best way, if it is stressed by the pressure in the shroud area only, and if the slide bearings are fixed in a common bearing housing.

For saving maintenance costs, it is further helpful if the shroud is connected to the pump casing by separate bolts. In this case, it will be possible to remove the bearing bracket unit to change the antifriction bearings, or to check the shroud thickness by ultrasonic testing without emptying the pump or stress relieving the system as mentioned before under CONSTRUCTIVE DESIGN.

The shroud should be sealed from the atmosphere by a chambered asbestos free gasket. Common materials for shroud constructions are 18.10 CrNi S.S. (type 316), Hastelloy C or ceramic materials such as zirconium oxide. Sealless pumps with shrouds of zirconium oxide have no eddy current losses and no additional power consumption, compared to conventional pumps.

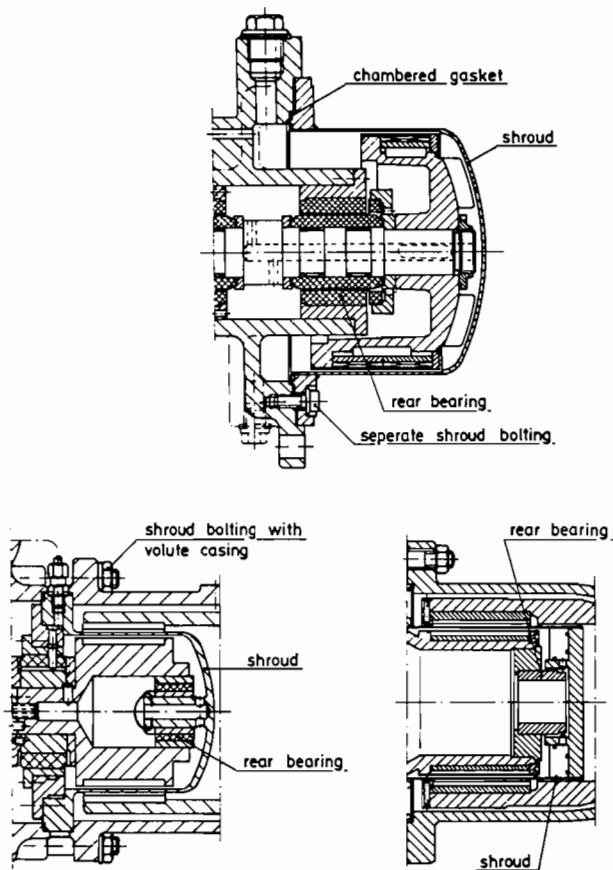

Figure 11. Shroud Constructions.

#### Shroud Protection from Ball Bearing Failure

The running time of conventional industrial pumps is limited by the shaft sealing system. One major chemical company has conducted a survey of its conventional pumps which indicated an average lifetime of 18 to 24 months for mechanical seals. If the seal fails during this period, and the defective seal parts are being exchanged, maintenance people normally renew the antifriction bearing at the same time. Thus, bearing damage occurs rarely on those pumps.

Experiences with sealless magnetically driven pumps have shown that the wear resistant SiC slide bearings have almost unlimited life and run several years without failure. However, defects on the antifriction bearings behind the shroud are still possible, if they are not being controlled or replaced as part of standard preventive maintenance.

Therefore, the outer magnet coupling must be designed (Figure 12) so that the gap between coupling circumference and bearing bracket is smaller than the gap between outer magnet ring and shroud. That means, in case of defective antifriction bearing and eccentric run of the outer magnet coupling, the magnet ring would not rub on the shroud, but the support ring would rub on the bearing bracket. Thus, destruction of the shroud by failure of the antifriction bearing is precluded. The proper running of the rotating coupling half can additionally be controlled through approximation sensors or contact thermometers.

#### MAGNET LOSSES, EDDY CURRENT LOSSES, COUPLING AND PUMP EFFICIENCY

The efficiency is shown in Figure 13 of magnet couplings with metallic shrouds. Attention should be paid to the influence of

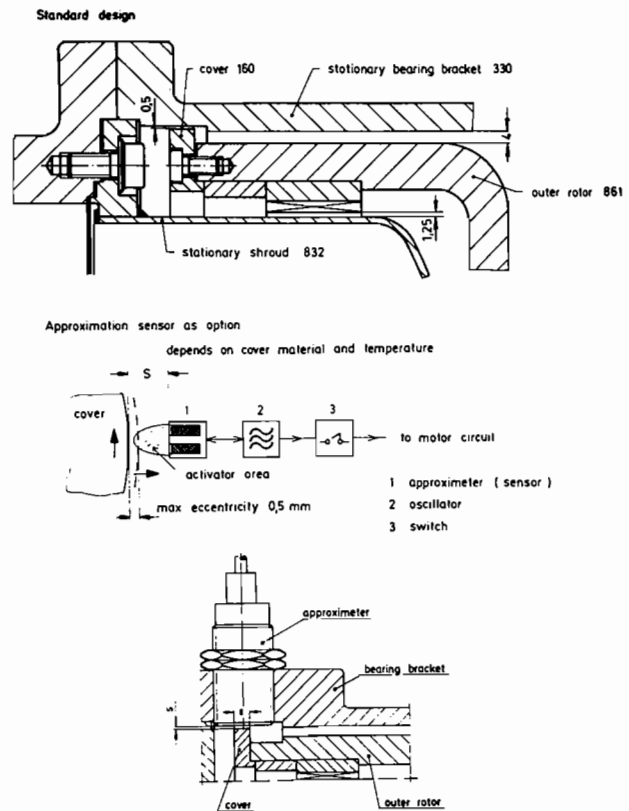

Figure 12. Shroud Protection Against Ball Bearing Failure.

the pump speed and to the shroud material on the coupling efficiency. With a speed of 1750 rpm and the use of a hastelloy shroud a coupling efficiency of 97 percent is obtained. It must also be noted that losses will not occur when using ceramic shrouds (i.e., zirconium oxide).

The standard pump curves, submitted by the vendor together with the pump offer, display the hydraulic efficiency without magnet losses. The total efficiency of a magnetically driven pump can be calculated as follows:

$$\eta_{Pp} = \eta_{hydr} \times \frac{P_{hydr}}{P_{hydr} + P_v}$$

$\eta_{hydr}$  = Hydraulic efficiency in acc. to pump performance curve

$P_{Pp}$  = Absorbed power in acc. to pump performance curve

#### TEMPERATURE RESISTANCE OF MAGNET MATERIAL

The transmissible power of a magnetic coupling depends generally on the operating temperature that is prevailing on the magnet. How much the transmissible torque decreases at increasing temperature is depicted in Figure 14. The total decrease is the result of reversible and irreversible losses. Irreversible losses arise only during initial warming of the coupling, and keep steady after the coupling has cooled down. The reversible losses rise linear with the temperature under operating conditions. It is noted that this decrease of torque at elevated temperature has no influence on the pump efficiency.

The antifriction bearings are located directly behind the shroud, therefore the shroud temperature must not exceed 210°C and, in special cases, 250°C. The Curie temperature caus-

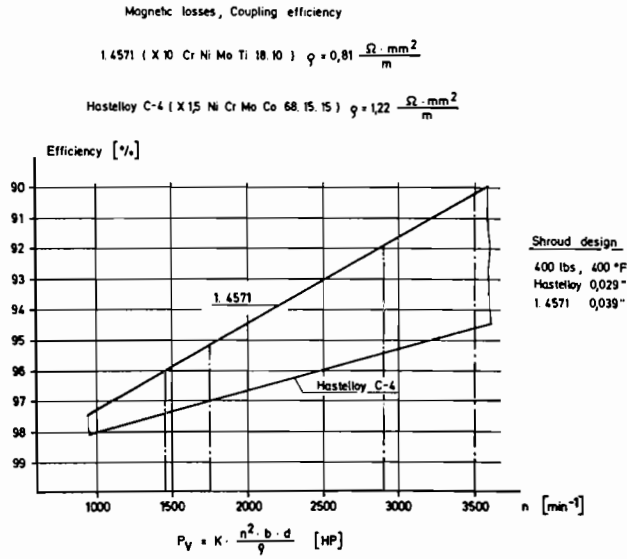

Figure 13. Coupling Efficiencies.

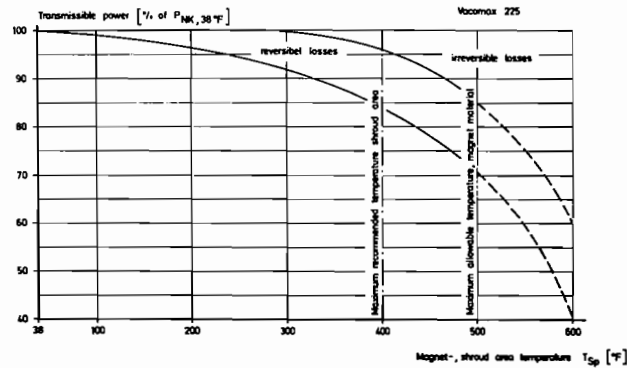

Figure 14. Temperature Resistance of Magnetic Coupling.

ing a total demagnetization of the magnets, is 700°C for samarium cobalt.

### MAGNETIC DRIVEN PUMPS, HIGH TEMPERATURE DESIGN

For handling thermal oil at operating temperatures up to 400°C without external cooling, a pump design has been developed that makes allowances for the heat resistances of the magnetic material mentioned above, and keeps the operating temperatures on the antifriction bearings behind the shroud within the permissible low limits. Between the volute casing and the bearing bracket with magnetic coupling, a cooling device is provided conducting heat to the atmosphere and, thus, causing the temperature in the shroud area to be considerably below the operating temperature of the pumpage.

The temperature reaction of this pump design is represented in Figure 15. As shown, the shroud temperature is 160°C, even at pumpage temperatures  $T_E$  in the range of 250°C to 300°C.

### MAGNETIC DRIVEN PUMPS WITH HEATING JACKET

When handling liquids like phenol, DMT-dimethyl-terephthalate, phthalic anhydride, tar, etc., with a melting and

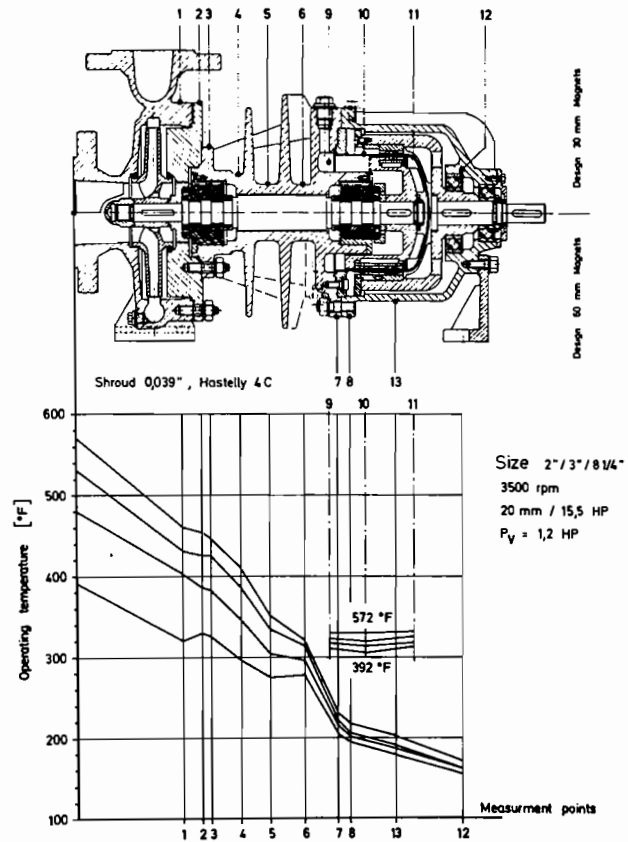

Figure 15. Surface and Shroud Temperature, High Temperature Pump.

crystallization point above the ambient temperature, a heatable pump is required. In order to avoid solidification inside the pump, a heating jacket is provided in the volute casing and in the magnet area. Such a pump is depicted in Figure 16. The temperature curve relates to a pump heated up for one to one and one-half hours during standstill, at different temperatures of the heating liquid passing through the heating jackets of the volute casing and shroud.

For example: If the melting point of the liquid is 90°C to 100°C, a heating liquid of 150°C is required to ensure that the pumpage is completely melted inside the pump. By installation of a temperature probe (Figure 6), the pump can start up only when the melting temperature is reached.

### SELECTION OF MAGNET COUPLING AND DRIVER

In conventional centrifugal pumps with mechanical seals or gland packings, and with an elastic coupling or a mechanical connection between the pump and motor shaft, it is sufficient to select a driver with a rated power that is higher than the maximum expected hydraulic power of the pump (PH, respectively PH, max).

The elastic coupling must be dimensioned such that transmission of the driving power to the pump shaft is assured. If these conditions are met, it is also guaranteed that the pump and motor speed coincide and the required performance will be obtained.

However, this is different in magnetically driven pumps. There is no mechanical nonpositive connection between motor

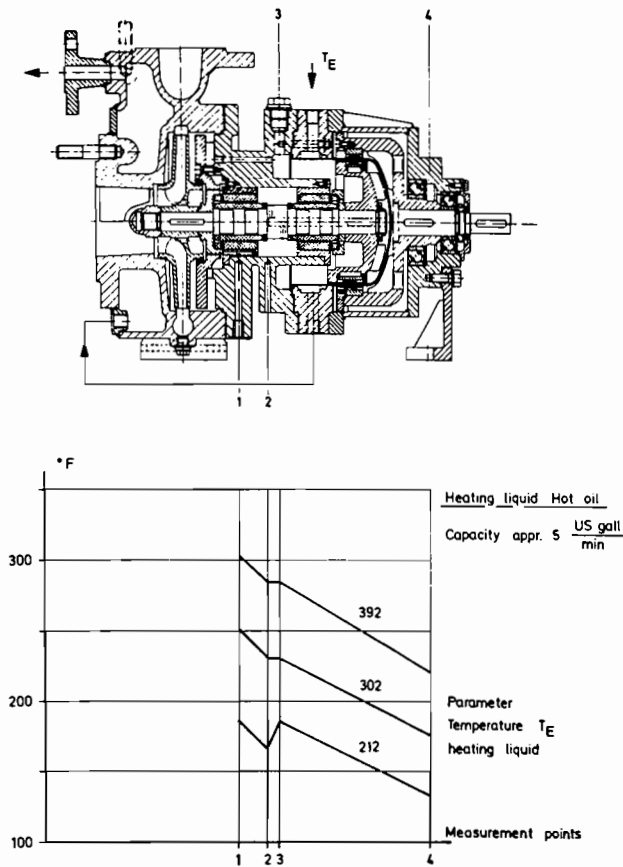

Figure 16. Temperature Pump with Heating Jacket.

and pump shaft. Both shafts are connected through the magnetic field lines of the magnetic coupling. In order to avoid a break of such field lines during startup and operation, the sizes shown in Figure 17 must be in a certain proportion to each other.

Performance:

- $P_H$  : Hydraulic power for rated capacity and rated differential head in accordance to the standard pump curves, under consideration of density and viscosity of the pumpage.
- $P_{H,max}$  : Hydraulic power at maximum capacity for the rated impeller in acc. to the standard pump curves, under consideration of density and viscosity of the pumpage.
- $P_V$  : Magnetic losses
- $P_{N,K}$  : Transmissible power of the magnet coupling at ambient temperature
- $P_{N,K,T}$  : Transmissible power of the magnet coupling at operating temperature
- $P_p$  : Rated power at rated capacity  
 $P_p = P_H + P_V$
- $P_{p,max}$  : Rated power at end of curve  
 $P_{p,max} = P_{H,max} + P_V$
- $P_M$  : Rated motor power

To avoid decoupling of the magnet coupling during startup against open discharge valve, the following must be granted:

$$S_{available} = \frac{P_{N,K,IA}}{P_M} > 1$$

$$S_{required} = \frac{J_2}{J_1 + J_2} \times 5,5$$

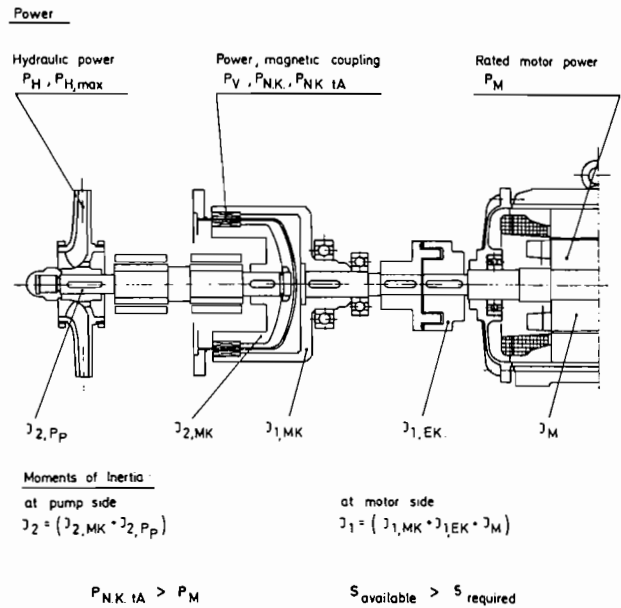

Figure 17. Startup Conditions, Magnetically Driven Pumps.

$$P_{N,K,T} > P_{p,max}$$

$$P_{N,K,T} > P_M$$

(1)

Moments of Inertia:

- $J_1$  = Moment of inertia, drive side  
 $J_1 = J_{1,MK} + J_{1,EK} + J_{1,M}$   
 $J_{1,MK}$ : Moment of inertia, outer rotating magnet coupling  
 $J_{1,EK}$ : Moment of inertia, elastic coupling  
 $J_{1,M}$  : Moment of inertia, electric motor
- $J_2$  = Moment of inertia, pump rotor  
 $J_2 = J_{2,NK} + J_{2,PP}$   
 $J_{2,MK}$ : Moment of inertia, inner rotating magnet coupling  
 $J_{2,PP}$ : Moment of inertia, impeller

With the moments of inertia, the required start-up coefficient can be found:

$$S_{req} \frac{J_2}{J_1 + J_2} \times K$$

K: Multiplier, found by experience, 5,5 for chemical standard pumps

With the motor power and the transmissible coupling power at operating temperature, the available start-up factor is found:

$$S_{available} \frac{P_{N,K,T}}{P_M} > 1$$

Start-up without decoupling under direct-on-line-start conditions is guaranteed if:



$$S_{\text{available}} > S_{\text{req}} \quad (2)$$

If the relations 1 and 2 are fulfilled, no problems during startup on site will occur.

**PUMP PROTECTION BY TEMPERATURE PROBES**

Regarding canned motor pumps, the fluid in the stator can and the rotor area is heated up by eddy current losses in the can and by electrical losses in the motor. Therefore, temperature rise in these pumps is remarkably higher than shown in Figure 5 presenting a magnetically driven pump. That means, temperature probes are a must for such pumps, especially when operating in hazardous areas.

Sealless magnetically driven pumps can generally operate without temperature probes. However, temperature probes would protect these pumps against any trouble during startup and operation. Recommended installation is shown in Figure 18. The temperature probe detects the shroud temperature and, if connected to the motor circuit, shuts off the pump when the temperature level reaches the maximum allowable limit.

It must be considered that nearly all possible troubles on magnetically driven pumps generate additional heat and temperature rise in the magnet or shroud area. In all these cases, the temperature probe will switch off the pump before serious mechanical damages happen.

Protection against the following failures is guaranteed:

- *Dry-run*—The silicon carbide bearings can run without liquid for a short period and not cause any problems. In this case, no internal circulation exists for transferring the heat from the shroud that is generated by the magnetic losses. It can be taken from Figure 15 that the shroud temperature in this case rises remarkably within a very short time.
- *Running against closed discharge valve*—Temperature will rise according to Figure 5.
- *Decoupling of the magnetic coupling*—In case of improper selection of the magnetic coupling and decoupling of the magnetic flux lines, only the outer magnet follows the motor speed. The inner magnet does not move and no internal circulation will take place. The temperature rises in the same manner as under dry run conditions.
- *Internal circulation holes stuck by polymerized or solidified pumpage*— Same effect as described under A and B.
- *Solids stuck between inner rotating magnets and shroud*— Solids will be rubbing on the shroud surface, friction generates heat and also temperature rise.
- *Internal rotor is rubbing on the shroud*— In case of improper running of the rotor and rubbing on the shroud surface, additional heat will also be generated as described in case E.

It is recommended that a temperature control display be installed which indicates the temperature under proper running conditions after startup and allows to set the maximum permissible temperature 10°C above the normal temperature at highest ambient and operating temperature.

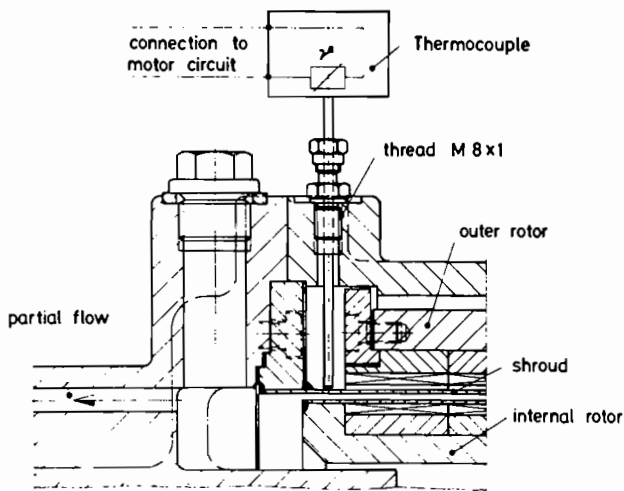

shroud temperature rise under dry running conditions

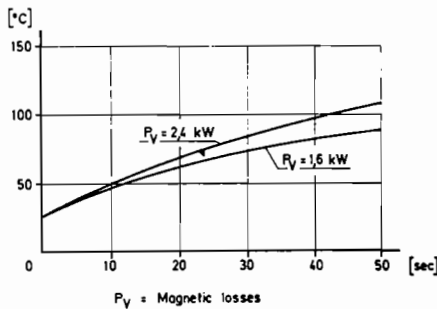

Figure 18. Thermo Probe, Shroud Temperature Detector.