

CHARACTERISTICS OF THE RECIPROCATING PUMP

by

John E. Miller

Principal Engineer

White Rock Engineering, Incorporated

Dallas, Texas



John E. Miller graduated from Pennsylvania State University in 1933, with a degree in Petroleum and Natural Gas Engineering. He saw varied service in the Alberta, Canada, oilfields as a Professional Engineer with Oilwell Division of U.S. Steel Corporation, self employed, Hughes Tool Company, a Petroleum Engineer with California Standard Company, and Denton-Spencer. He returned to Oilwell in 1946.

He then spent 30 years as Development Engineer for Oilwell Division in Dallas, during which time he designed most of the expendable pump parts for the Oilwell and Wilson-Snyder pumps, particularly those used in severe slurry service. It was during that time that he developed the well known Miller Number System for the determination of slurry abrasivity, ASTM Standard G75-82. He also did extensive research work in reciprocating pump operation and suction requirements, such work leading to the invention of the suction stabilizer.

He organized White Rock Engineering, Incorporated, in 1974, to offer consulting services in pump design and pulsation control, slurry pumping and special laboratory and field testing. Mr. Miller has been granted seven patents (others pertaining to pumps pending), and he has published numerous papers and technical articles, culminating in the publication of a book entitled *The Reciprocating Pump: Theory, Design and Use*.

He is a Fellow member of ASME (Committee PTC 7.2 Power Test Code for Reciprocating Pumps), and ASTM (Committee G-2 Erosion and Wear). In 1984, Mr. Miller was presented with the North Texas Section ASME Award for Outstanding Achievement. He is the recipient of the 1987 Henry R. Worthington Medal for "extensive research into reciprocating pump design."

ABSTRACT

A discussion is presented on the physical differences between centrifugal pumps and reciprocating pumps. The disparities are explained in a nonbiased manner and such knowledge should precede an introduction to reciprocating pump basics.

The discussion on reciprocating pumps reiterates the theories of operation, including suction and discharge aspects, NPSH, pulsation control, and finally, a brief discourse on reciprocating pump design parameters with an example.

INTRODUCTION

One would think that after many years, an explanation of the differences between a positive displacement (reciprocating)

pump and a centrifugal pump would be an exercise in redundancy. But the differences are so profound that before the characteristics of a reciprocating pump can be appreciated, these differences must be reviewed.

PUMP DISPARITY

Aside from the fact that the centrifugal pump is a kinetic energy device, as opposed to the direct positive displacement of a reciprocating pump, most important is the "continuity" existing in the centrifugal pump where, as seen in Figure 1, there is always liquid communication between the discharge and the suction of the pump. Any abnormal disturbances in the suction may affect the discharge and vice versa.

A "discontinuity" always exists between the discharge and the suction of a reciprocating pump and liquid communication can never exist in a normally operating pump. For this reason, the

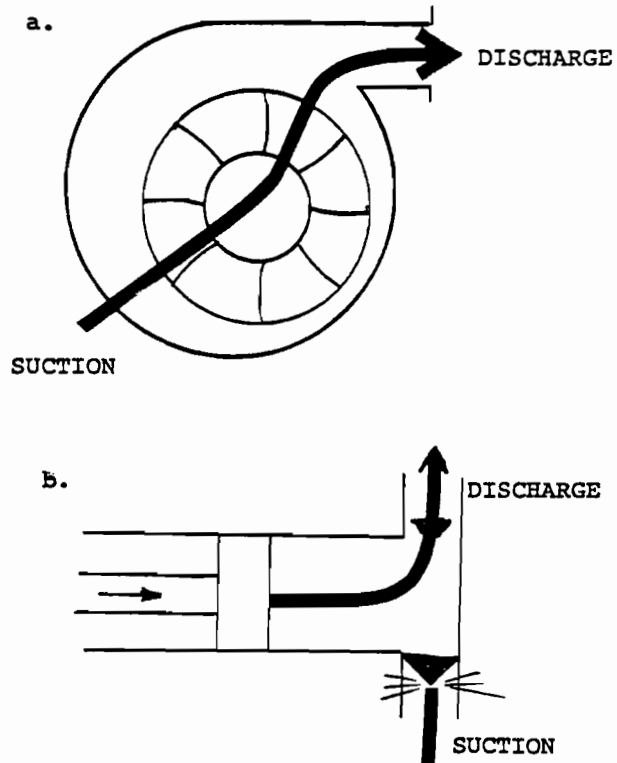

FIGURE 1

- a. Centrifugal continuity
- b. Reciprocating discontinuity

Figure 1. Liquid Continuity in Pumps. a) centrifugal continuity, b) reciprocating discontinuity.

suction and discharge systems of a reciprocating pump must be analyzed and treated separately.

The performance of the two types of pumps is about as different as can possibly be conceived. The two typical pump types, with ratings of six different sizes are listed in Table 1.

Table 1. Pump Disparity

Power hhp	Reciprocating 1000 gpm psi	Centrifugal 100 psi gpm
6	100	100
30	500	500
60	1000	1000
120	2000	2000
240	4000	4000
480	8000	8000

This data, plotted in Figure 2, graphically shows the rapid divergence of the performance of the two pumps of equal horsepower, starting at 6 HHP, the only point where the two offer equal performance), neglecting pump cost and efficiency. Accordingly, apart from that single condition, it seems that the selection of one over the other depends entirely upon the service—one for low head high delivery and the other for high head low delivery. There is no compromise!

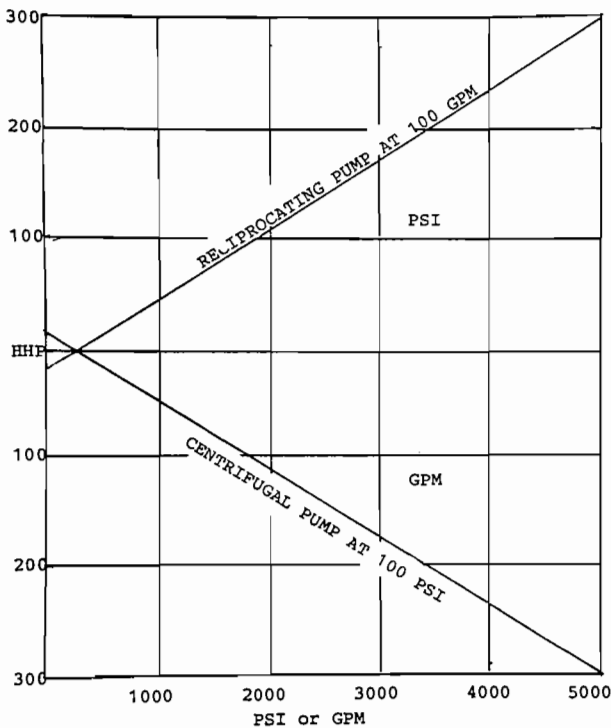

Figure 2. Pump Disparities.

This disparity can also be represented by the following equations showing the relation of parameters common to any device used to elevate the energy of a liquid for the purpose of moving it from point-to-point;

CENTRIFUGAL PUMP:

$$\frac{gpm_1}{gpm_2} = \frac{rpm_1}{rpm_2} = \frac{\sqrt{H_1}}{\sqrt{H_2}} = \frac{\sqrt[3]{bhp_1}}{\sqrt[3]{bhp_2}} \quad (1)$$

RECIPROCATING PUMP:

$$\frac{gpm_1}{gpm_2} = \frac{rpm_1}{rpm_2} = \frac{P_{d1}}{P_{d2}} = \frac{bhp_1}{bhp_2} \quad (2)$$

These disparities should not be controversial and they should be accepted with reverence for their respective place in industry.

RECIPROCATING PUMP CHARACTERISTICS

Reciprocating pumps exhibit certain typical flow variations in the discharge (outlet) and suction (inlet) caused by the rotary motion of the power end driving the displacement elements (pistons or plungers). This is demonstrated by the geometry in Figure 3 and the equations for instantaneous velocity:

$$V_{p\theta} = 0.042 \omega s (\sin \theta + \frac{s}{4L_c} \sin 2\theta) \quad (3)$$

$$V_{d\theta} = \Sigma V_p \times A_p/A_d \quad (4)$$

$$V_{s\theta} = \Sigma V_p \times A_p/A_s \quad (5)$$

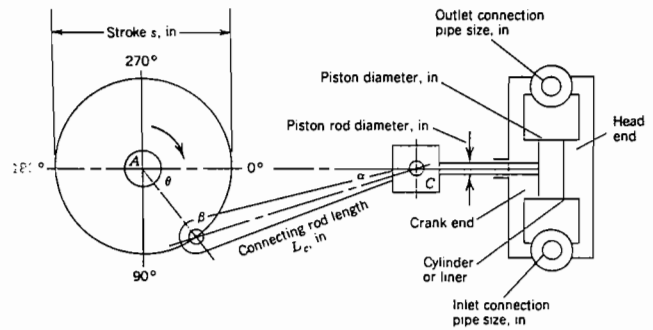

Figure 3. Pump Geometry.

The type of pump is responsible for large differences in the shape of the flow-pattern (Figure 4). This shape depends on both the ratio of connecting rod length to crank radius, and the loss of displacement on the piston rod end (crank end) of a double acting pump. Conventional pump design is such that the arrangement and number of cylinders generate different maximum and minimum flow rates. The flow rates are expressed as a percentage of the average as shown in Figure 5, which represents one typical pump geometry with specific L_c/r ratio. For instance, a triplex single-acting pump has six points of maximum flow rate per revolution.

These points are duplicated in both the discharge and the suction of a pump.

Because frictional pressure drop in a pipeline is a function of the square of the velocity, these flow variations will be converted into pressure variations (pulsation) following the same shape as the flow pattern.

Acceleration

In reciprocating pumps, again because of the typical harmonic motion, the liquid entering and leaving each pump cylinder experiences a "start-and-stop" flow with velocities ranging from zero to a maximum. This is shown in Figure 6 and is determined from the formula for acceleration.

$$a_{p\theta} = 0.042 \omega^2 (\cos \theta + \frac{s}{2L_c} \cos 2\theta) \quad (6)$$

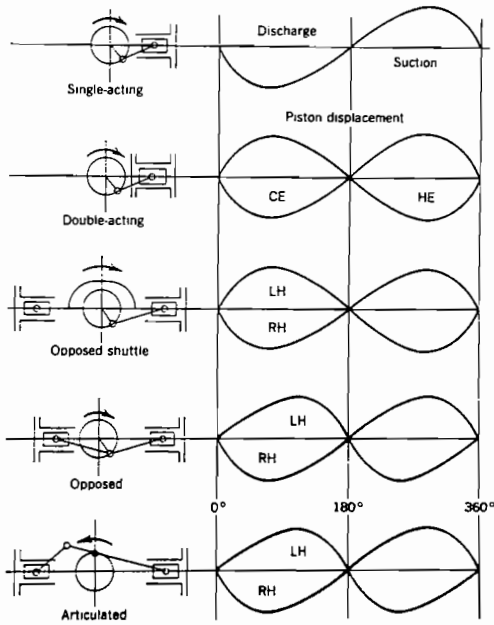

Figure 4. Reciprocating Pump Mechanics. CE = Crank end; HE = head (cylinder) end; RH, LH = right hand and left hand of opposed-cylinder pumps.

The acceleration of the liquid at the suction and discharge connections is the result of the cylinder-generated acceleration and is calculated by:

$$a_{s\theta} = \Sigma a_p \times A_p/A_s \tag{7}$$

$$a_{d\theta} = \Sigma a_p \times A_p/A_d \tag{8}$$

The liquid, having mass, is subject to Newton's law of motion, and acceleration is converted to pressure according to the basic premise of $F = Ma$:

$$P_{ap\theta} = 0.0069 \times L \times \rho \times a_p \tag{9}$$

$$P_{as\theta} = 0.0069 \times L \times \rho \times a_s \tag{10}$$

$$P_{ad\theta} = 0.0069 \times L \times \rho \times a_d \tag{11}$$

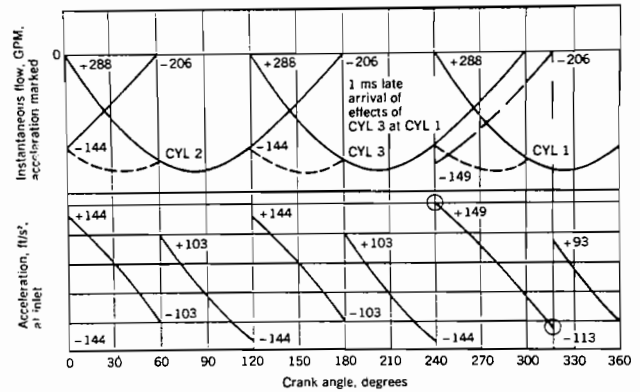

Figure 6. Flow and Acceleration Values. Triplex single-acting pump.

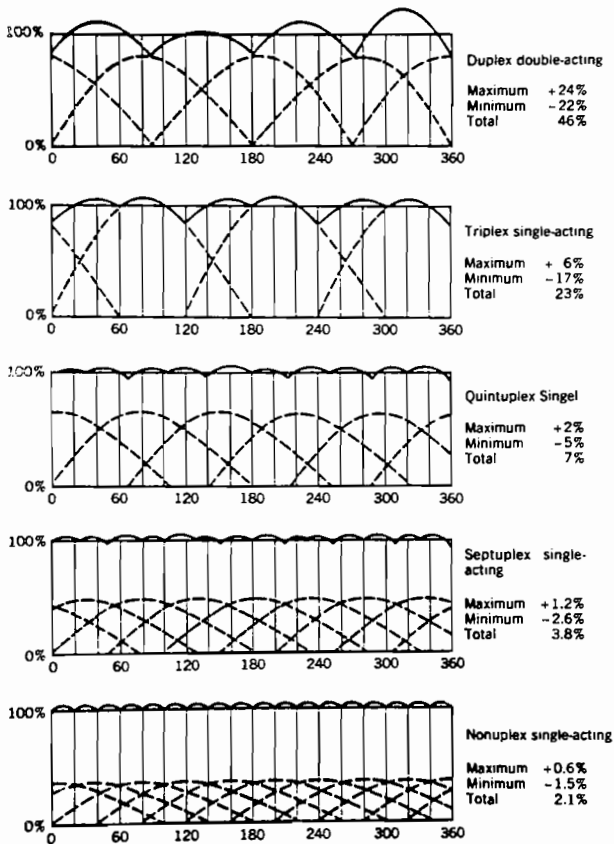

Figure 5. Flow Patterns. Flow variations for multicylinder pumps.

Suction Acceleration

The theory of suction pressure requirement for a given pump indicates that the instantaneous pressure must always be of sufficient magnitude to accelerate the mass of liquid in the suction pipe at that instant. Otherwise, the reduced pressure created by the sudden demand would tend to vaporize the liquid and cause cavitation in the cylinder. Cavitation, in this sense, is defined as the recovery from vaporized liquid (due to reduction in pressure below its vapor pressure) resulting in pulses of pressure as the vapor pockets suddenly collapse.

Cavitation can generate pulsation and subsequent pipe vibration due to such repeated pulses. Of equal importance is the damage to pump parts. If the collapsing pocket is close to any metal part, the forces involved in the collapse will send a microscopic jet of liquid against the metal, eventually causing erosion.

The problem of suction acceleration in a pump was recognized many years ago and has been included in the well known methods of calculation of NPSHA (Net Positive Suction Head Available).

NPSH

The term NPSH (Net Positive Suction Head) for reciprocating pumps was borrowed from the centrifugal pump industry. The suction pressure at the reciprocating pump inlet influences performance in the matter of volumetric efficiency and hydraulic noise, both of which affect pump life.

With the reciprocating pump speeds used in recent years, it has become necessary for pump manufacturers to define the minimum pressure at which a given pump will operate satisfactorily. A decision to retain the term NPSH for reciprocating

pumps (but in units of “psi” instead of “feet head”) does not remove the confusion that has been inherited.

Definition of NPSH

NPSHR (net positive suction head required)

That absolute pressure in psia of water (above vapor pressure at pumping temperature) as determined by test, required at the pump inlet to sufficiently fill the pump cylinders so that no more than a three percent (three percent) drop in volumetric efficiency from maximum is achieved (Figure 7).

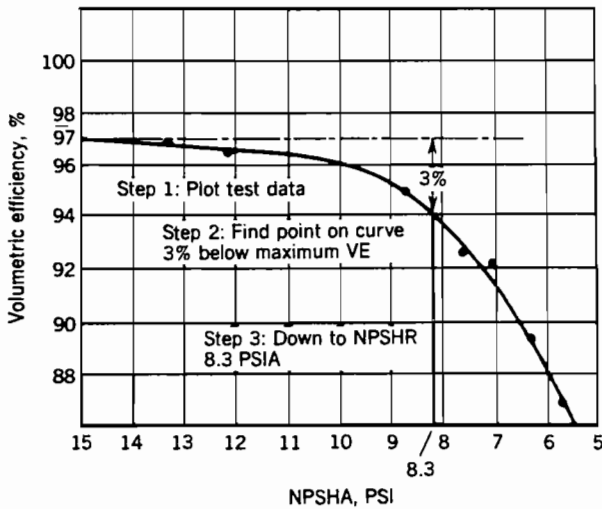

Figure 7. Plotted NPSH Test Data. Idealized triplex single-acting pump pressure waveform, showing the effect of surge like acceleration pressures.

NPSHA (net positive suction head available)

That absolute pressure in psia of liquid being pumped (less vapor pressure at the pumping temperature) available at the pump inlet. It can be calculated from known suction system parameters, by Equation (12), or it can be measured from test data applied in Equation (15). The widely used formula for calculation of NPSH from suction system parameters is:

$$NPSHA = (P_a \pm P_g \pm P_z - P_{vp}) - P_f - P_{ac} \quad (12)$$

Where

$$P_{ac} = C_1 L N Q S / D^2 \quad (13)$$

Values for the constants C_1 are based on a typical pump L_c/r of 6:1. A more precise value of C can be derived from the formula:

$$C_1 = 0.0132 \times a_s (D^2 / N Q S) \quad (14)$$

Table 2. Constant C_1

Pump Type	C_1	Pump Type	C_1
Simplex DA	0.001660	Triplex SA	0.000339
Duplex SA	0.001032	Sextuplex SA	0.000237
Duplex DA	0.000624	Quintuplex SA	0.000199
Quadruplex DA	0.000434	Septuplex	0.000146
Triplex DA	0.000338	Nonuplex SA	0.000107

Another formula for NSPH using pump suction gauge pressure is:

$$NPSHA = P_a \pm P_{gs} - P_{vp} + P_v \quad (15)$$

Where

$$P_v = 0.0011137(\text{gpm})^2 S / D^4 \quad (16)$$

These equations simply that the net positive suction head requirement (NPSHR) for reciprocating pumps is a simple, fixed value. In the first place, because reduction in NPSHA lowers the volumetric efficiency at a certain unpredictable rate, a decision must be made as to which NPSH is satisfactory for reliable pump operation. It seems that the three percent drop in volumetric efficiency from a maximum, used in some test methods, (Figure 7), is satisfactory in most cases. There is also some doubt about the true effect of acceleration as derived from theory. One of the first expressions of acceleration pressure is an empirical one by Wright of Worthington Pump Division of Dresser Industries developed several years ago, where $k = 1.4$ for cold water

$$H_{ac} = LVNC_2 / \text{kg} \quad (17)$$

Table 3. Constant

Pump Type	C_2	Pump Type	C_2
Simplex DA	0.200	Triplex SA	0.066
Duplex SA		Sextuplex SA	0.055
Duplex DA	0.115	Quintuplex SA	0.040
Quadruplex DA		Septuplex SA	0.028
Triplex DA	0.066	Nonuplex SA	0.022

Except for different terms and the liquid density as accounted for in the term, kg, it, too, is related to the basic Equation (10).

The author generated Equation (13), which again complies with the basic formula, except it is comprised of terms usually used to define pump characteristics. These equations provide results which are close enough for practical purposes.

Both equations for acceleration pressure (13) or head (17) involve a constant, C_1 or C_2 . These constants are used in converting to the proper units. However, they also serve as factors directly proportional to the percentage of flow (velocity) variation inherent in each pump type, and from which the acceleration is derived for the pump inlet or outlet.

Wright stated that “this calculation is useful only for short sections of pipe,” and this has been confirmed by many years of experimental work. In fact, in suction pipe lengths greater than about 15 ft, the formula (as used in the requirement for NPSHA) loses validity. If one calculates the acceleration pressure (or head) for a typical pump with a 100 ft long or longer suction pipe (which is quite common) it will be unrealistic. The pump will operate with much less NPSHA. Accordingly, there must be a quirk in the formula.

In spite of these statements, and particularly with the trend to higher pump speeds, acceleration can still cause pump operating problems in both the suction and discharge. However, in the case of suction systems, experience has shown that additional pressure (or head) alone may not overcome the effects of acceleration as stated in the definition of NPSHA. The effect of acceleration of the liquid at the beginning of a piston suction stroke is a time-dependent function. The maximum acceleration occurs in an instant just preceded by a discontinuity of extreme proportions and of short duration.

The acceleration pressure (p_{ac}) included in the NPSHA calculation for multicylinder pumps is that secondary forces appearing at the pump inlet as the result of primary forces generated by the individual pistons. These secondary forces are supposedly of much lower magnitude, because it is assumed that the overlapping of the cylinders allows the deceleration of one to cancel some of the acceleration in the other.

Nevertheless, the individual primary acceleration forces generated by each cylinder are of the same magnitude regardless of the number of cylinders.

How Acceleration Affects Pump Performance

In Figure 6, the primary acceleration on the suction stroke is shown as 288 ft/sec for each plunger in a particular triplex pump. Even though the resultant or secondary force is only 144 ft/sec (not corrected for suction pipe diameter), the greater disturbances generated in the cylinder at that instant are seen by the entire suction system. When these resultant forces are transferred to the pump suction flange, the above theory does not strictly apply, since the source of two or three simultaneous events occurs at finitely separate points, determined by the pump and suction manifold configuration and the pump speed. Therefore, wave velocity must be taken into account.

In Figure 6, assume cylinder one is closest to the inlet flange and about one millisecond later, the effect of cylinder three will be seen at the observation point located at the inlet flange. Such delay changes a nice theoretical wave form and tends to distort it as shown. At that instant (at 240 degrees) the resultant forces are even greater, 149 as compared to 144 ft/sec, followed by a drastic range of deceleration.

All of the acceleration "bursts" generate pressure pulses in the suction. These do not necessarily cause "cavitation," but even in well designed systems these hydraulic pressure pulses are of the "water-hammer" type that show a frequency in the order of 75 to 200 Hz, regardless of any different parameters, and are typical of the repeated harmonic decaying type of waveform. These can be detected in both suction and discharge at the opening and closing of the pump valves, even in dampened pumps as shown in Figures 8 and 9.

In most cases, as in the examples shown, these high frequency disturbances are not detrimental in the discharge, because their amplitude is a small percentage of the low-frequency flow-generated pulsations. However, in the suction of the pump where dynamic flow-induced pressure changes are of low amplitude and energy, again being a percentage of the actual suction pressure, these acceleration pressure disturbances can be an overriding factor. Their excursions to the negative side can result in possible cavitation, in spite of a theoretically adequate average NPSHA.

Discharge Acceleration

Reciprocating pumps of ordinary design with their distinctive discharge flow characteristics generate pressure due to the vari-

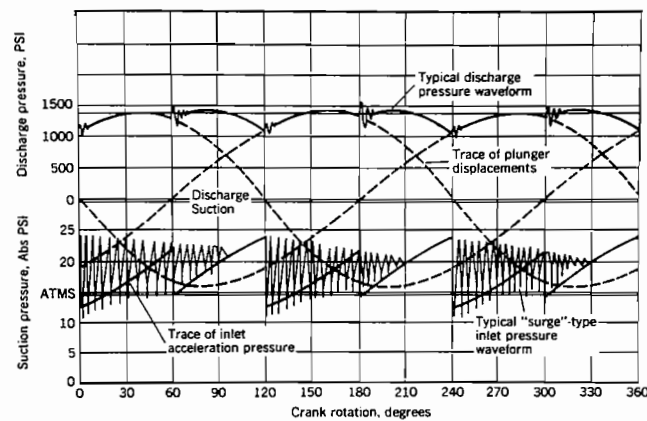

Idealized triplex single-acting pump pressure waveform, showing the effect of surge-like acceleration pressures.

Figure 8. Idealized Triplex Single-Acting Pump Waveform.

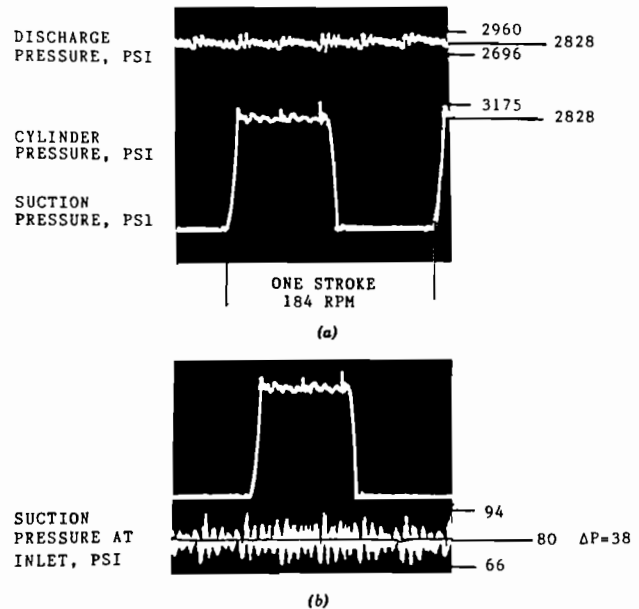

Figure 9. High Frequency in Waveforms.

ation in flow that is linear with speed. But the acceleration of the liquid at the beginning of each increase in flow rate generates a pressure proportional to the second power of the speed. Accordingly, acceleration effects from high speed are the greatest enemy of satisfactory pump performance.

In typical hydraulic systems, where the discharge pressure is generated by the pump(s) in question, such pressure is the result of liquid flowrate friction losses in a rather long pipeline; or through some sort of restriction, and the hydraulic pressure variations (pulsations) due to flow are predominant over those generated by acceleration. However, when the pump is discharging directly into a vertical head or other system with very small friction losses, the acceleration pressure variations can become predominant.

For example, Figure 10(a) shows a pump forcing water out of a mine shaft at a depth of 2,000 ft through a vertical pipeline that has a friction loss of 1 psi/1,000 ft. It would show a discharge pressure of $2,000 \times 0.43 + 2 = 862$ psi. It is obvious that a typical long horizontal pipeline, Figure 10(b), would present completely different dynamic conditions to the pump with the same discharge pressure. Also consider a pump feeding an existing pressured pipeline with short, low-friction connecting lines.

Some of these applications may exhibit discharge pressure pulses of the water-hammer type due to accelerations as discussed, with amplitudes far in excess of those normally generated by flow variation. Experience shows that these high frequency pulses (50 to 200 Hz) cannot be attenuated by the use of conventional gas-bladder devices, simply because they cannot react quickly enough to absorb much of the pulse.

Since such acceleration disturbances are related to pump speed to the second power, unexpected problems from these excessive disturbances in vertical lift application could certainly be minimized by limiting speed (Figure 11).

Because problems have been encountered in the process industry, particularly from dissolved air or petroleum gas in hydrocarbons where large amounts are absorbed, there may be unfounded fear that such air absorption in water will interfere with accurate results when an air blanket is used to increase the suction pressure in a water system. But water at ambient temperature and atmospheric pressure will absorb only about one per-

cent by volume of air, nitrogen, or hydrogen (compared to about 50 times that amount of CO₂). So, for practical purposes, the effect is of little consequence.

NPSHR is a subtle characteristic of a pump and is difficult to determine in absolute terms. Its value depends on at least ten of the following conditions which themselves may be difficult to

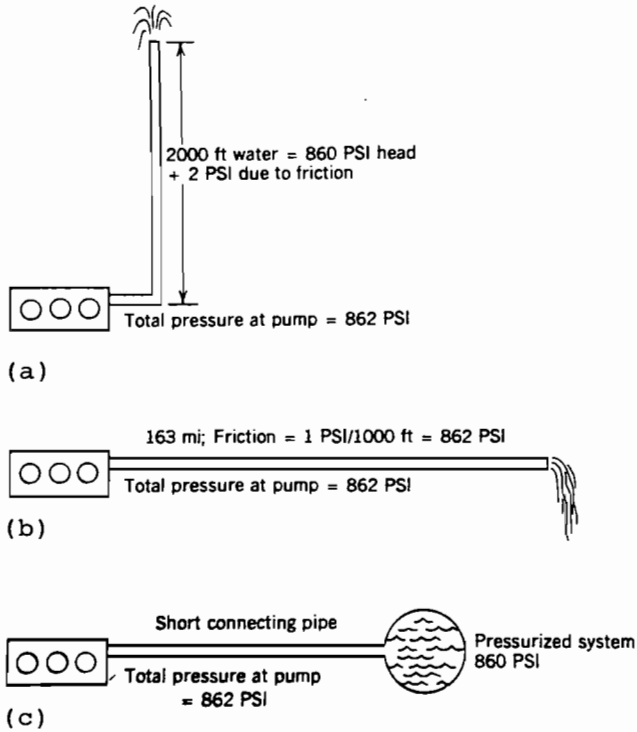

Figure 10. Pump Discharge Conditions.

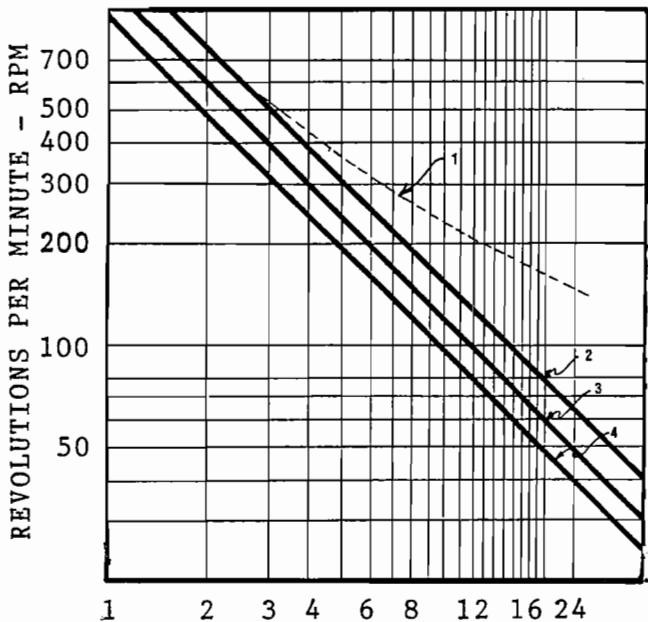

Figure 11. Recommended Pump Speed vs Stroke. 1)Hydraulic Institute for cold water; 2)constant 260 fpm for cold water; constant 200 fpm for slurry; 4)constant 160 fpm for extreme abrasion.

precisely define: Liquid density, vapor pressure, viscosity and dissolved air or gas, pump speed, piston diameter, valve type, valve through area, valve spring load, spring rate, liquid passage configuration, and stuffing box leakage. The aspects of some liquids, particularly hydrocarbons, complicate the conversion from "water NPSHR" to such liquids. A correction must be first made to adjust the "water NPSHR" by the specific gravity of the new liquid.

Then, with highly volatile liquids, the suction pressure must be made equal to the corrected NPSHR plus the vapor pressure of the liquid at the pumping temperature.

It would be well to add at least 10 percent pressure as a safety margin in the case of possible air or gas absorption.

PULSATION CONTROL

The primary purpose of pulsation control for reciprocating pumps is to attenuate or filter out any pump-generated pulsating pressures which create forces in the piping system that cause vibration and noise. Pump pulsation frequencies are compared in Figure 12 to natural vibration frequency of some common pipe spans.

RPM	Frequency, Hz			
	Pump	Duplex Pulse°	Triplex Pulse°	Quint Pulse°
50	0.8	3.2	2.4	4.0
100	1.7	6.8	5.1	8.5
150	2.5	10.0	7.5	12.5
200	3.3	13.2	9.9	16.5

*Pulse = pump RPM × number of cylinders / 60

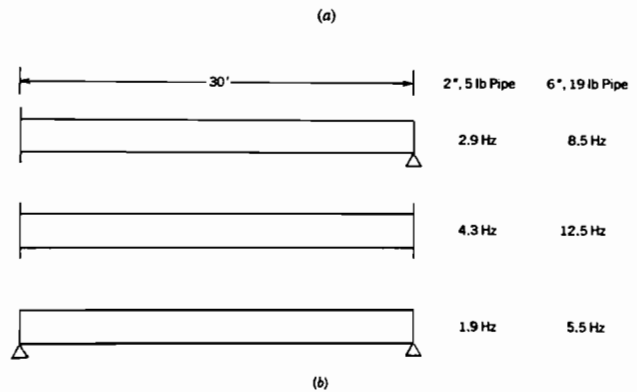
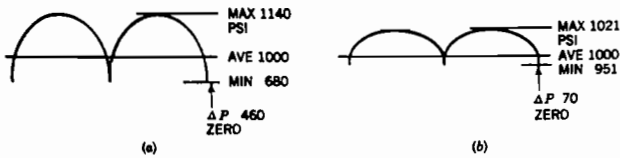

Figure 12. Typical Pump and Pulse Frequencies. a) typical pump and pulse frequencies; b) typical piping natural frequencies.

Another benefit of pulsation control is the reduction of fatigue of the pump liquid end and pump expendable parts. Reducing the pressure peaks seen by the pump piston will reduce the power end peak loading.

It is almost mandatory that multiple pump installations have well designed individual suction and discharge pulsation control equipment. Even though multiple pumps may be arranged to run at slightly different speeds, it is impossible to prevent them from frequently reaching an "in phase" condition where all of the pump flow or acceleration disturbances occur simultaneously. The extent of the pipe vibration caused by such disturbances can be multiplied by the number of pumps because the energy is similarly increased.

Fortunately, the amplitude of the individual pump pulsations can be reduced by the use of dampeners on each pump, so that



Methods of reporting degrees of pulsation and control. (a) Case I: Non-dampened waveform (from flow variation). (b) Case II: Dampened waveform (from flow variation).

Method A: Used throughout this book and recommended as standard. Percent residual pulsation pressure:

Case I: $\Delta P / Ave \times 100 = 460 / 1000 \times 100 = 46\%$
 Case II: $\Delta P / Ave \times 100 = 70 / 100 \times 100 = 7\%$ (4.14)

Method B: ΔP or change in pressure, min to max:

Case I: $\Delta P = 460$ PSI
 Case II: $\Delta P = 70$ PSI

Method C: Percent attenuation or suppression:

Case I and Case II:
 $\Delta P_1 - \Delta P_{II} / \Delta P_1 \times 100 = 460 - 70 / 460 \times 100 = 85\%$ (4.15)

Method D: Percent transmission ratio:

Case I and Case II:
 $\Delta P_{II} / \Delta P_1 \times 100 = 70 / 460 \times 100 = 15\%$ (4.16)

Important: ANY REFERENCE TO DEGREE OF PULSATION SHOULD APPLY TO THE TOTAL EXCURSION IN TERMS OF PRESSURE OR PERCENTAGE. FOR EXAMPLE, IN CASE I, THE TOTAL PULSATION OF 460 PSI (46%) IMPLIES THAT THE EXCURSION IS FROM 680 PSI (32% BELOW THE AVERAGE) TO 1140 PSI (14% ABOVE THE AVERAGE).

Figure 13. Reporting Pulsation and Control. Important: Any reference to degree of pulsation should apply to the total excursion in terms of pressure or percentage. For example, in Case I, the total pulsation of 460 psi (46%) implies that the excursion is from 680 psi (32% below the average) to 1140 psi (14% above the average).

their accumulated effect will be insignificant. There are several ways to report the magnitude of the hydraulic pressure pulsation and control (Figure 13). The reduction of the hydraulic pressure pulses by using pulsation control equipment is usually reported in total pulsation pressure “swing” as a percentage of average pressure.

It is important to reiterate that all reciprocating pumps introduce into the suction and discharge system at least three apparently unrelated pressure disturbances (Figure 14). Points of induced pressure, depicted as A, B, and C, in Figure 14, will be used frequently in the text. These include a low-frequency based on the rate at (2) Points of induced pressure, depicted as A, B and C, as shown in Figure 14, will be used frequently in the text which maximum flow velocity pressures at (A) occur; another of higher frequency due to maximum acceleration pressure at the beginning of each piston stroke at (B); and at the point of flow velocity change (valley) at (C). On this basis, the idealized pressure pattern should look somewhat like Figure 8.

Again as shown in Figure 14, even though increasing the number of cylinders will reduce the magnitude of the flow-induced “A” pulses, there is evidence that acceleration pressures of the “B” and “C” type are seen in all pumps and the magnitude is the same regardless of the number of cylinders.

It has been shown that identical forces are acting on the liquid in both the suction and discharge of a pump but there are usually great differences in the final results of these forces. One major difference is the fact that acceleration effects in the suction at “B” tend to separate the liquid into vapor or “cavitation” pockets

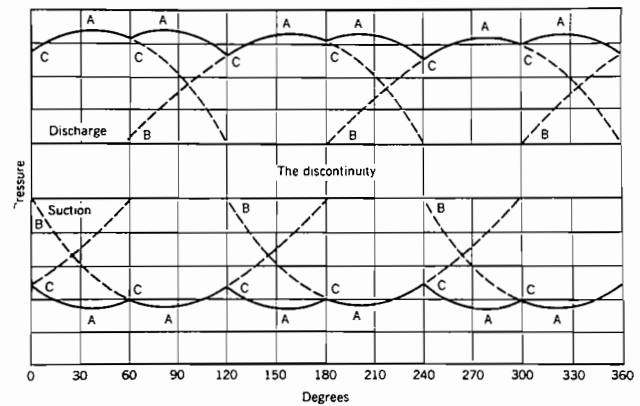

Figure 14. Points of Induced Pressure Disturbances. Triplex single-acting pump.

that collapse with a high magnitude pressure pulse. On the other hand, acceleration on the discharge side of the piston at “B” tends to compress the liquid and again create an impulse pressure pulse.

Suction System

The friction losses in a suction system are usually low because of the relatively short length and large diameter of piping involved. Accordingly, the flow-induced “A” pressures generated are of low magnitude based on the accepted percentage of change. For example, if the suction pressure is a static 25 psi, the 23 percent variation of a triplex single-acting pump would generate a theoretical “A” pressure variation of only 11.5 psi. This is hardly enough energy to set pipes in motion, compared to the “A” pressure variation of 460 psi in the discharge at 1,000 psi at the same flow variation.

But the forces of acceleration become the overwhelming disturbance in the suction. Pressure pulses of more than 25 psi are encountered in pumps with short suction piping. A small amount of dampening of the flow-induced 11.5 psi can reduce it to a negligible amount, leaving the 25 psi “C” acceleration pulsations present for whatever damage they can cause by possible cavitation.

DISCHARGE SYSTEM

To carry the example to the discharge, the same forces are at work but, as previously mentioned, the “A” pressure due to flow-induced pulsations of 460 psi become overwhelming. The 25 psi contribution from acceleration “C” is a small percentage (2.5 percent) of the total discharge pressure. An exception is when the pump is delivering into a low-friction, high pressure system such as a short vertical pipeline in a mine dewatering system (Figure 10), to an already pressured system such as a pressured pipeline through a short connecting pipe, or to an already pressurized system, such as hydraulic press accumulators and similar systems. In those cases, the acceleration pressures can become the overwhelming disturbance, particularly if the piping system is relatively long compared to a suction system (but considerably shorter than a “pipeline”).

Pulsation Control

There are two distinct types of pulsation dampeners. First is the energy-absorbing type (Figure 15), which uses a gas-filled envelope or bladder to absorb the “A” flow peaks and to give back that flow on the “lows,” thereby reducing the flow-induced pressure pulsations. This is the most efficient and widely used type.

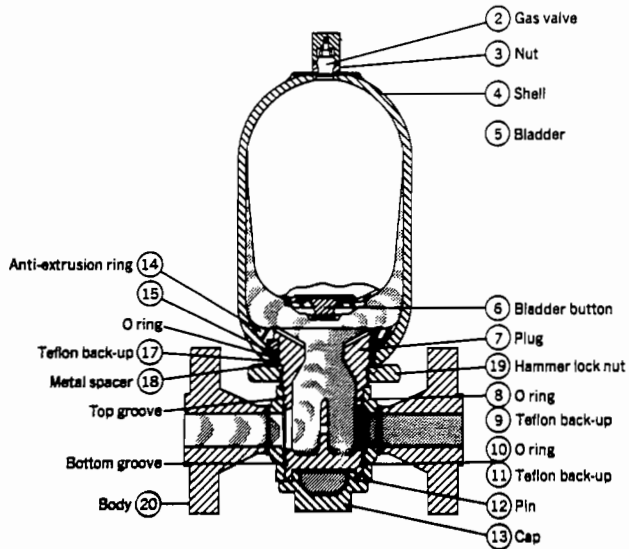

Figure 15. Pulsetone™ Gas Type Dampener (courtesy Greer Hydraulics, Incorporated).

The second is the acoustic type dampener (filter) (Figure 16) which operates on the principle of a volume-resistance network that filters out the pump-generated pulsation frequencies. The effects of both types of dampeners sometimes intermingle in that some acoustic effects are seen in the energy-absorbing type and vice-versa. There are even times when the two types can be deliberately combined for special cases.

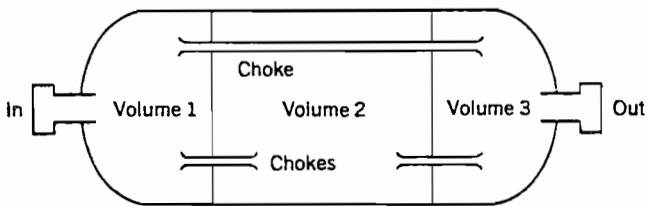

Figure 16. Acoustic Dampener.

One should recognize the fundamental traits of each type of dampener. The most important is the ability of the energy-absorbing type to attenuate low-frequency pulses, such as those generated by the pump rotary motion, and the combination of flow from each of the pump cylinders, basically rpm times number of cylinders. Accordingly, on the basis of a maximum of 500 rpm for most large pumps, the maximum frequency involved should not be over about 50 Hz.

Above 50 Hz, the strict energy-absorbing type of dampeners becomes less efficient. From 50 Hz to the region of 200 Hz, the acoustical type is rather efficient. But interestingly, it becomes exponentially more efficient and less complex with even higher frequencies. It is, therefore, evident that there may be a place for both types of dampeners. The performances of the most popular types on a typical pump are compared in Figure 17.

SUCTION STABILIZATION

For the most economical and efficient pump performance, particularly with the advent of higher pump speeds for greater capacity, the suction system deserves careful consideration. A

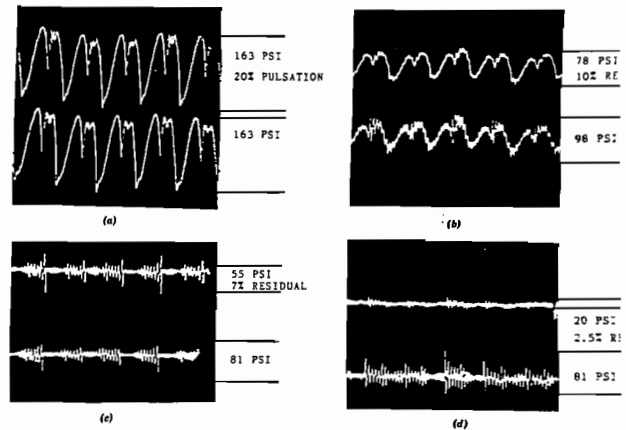

Figure 17. Performance of Different Dampener Types. 3 × 6 in triplex pump, 800 psi discharge. Top trace: Downstream of dampener. Bottom trace: Upstream of dampener. (a) no dampener. (b) acoustic-type dampener. (c) gas-type dampener. (d) greer flow-through dampener (Pulsetone™).

small energy-absorbing, gas-type dampener on the suction will alleviate the small amount of flow-induced "A" pulsations. In the case of acceleration-induced high frequency pulsations "B" and "C," it was discovered some years ago that the pump with a long suction system could be fooled into thinking it had its suction tank close to the inlet. This was done by installing a lumped volume (vessel) with in-and-out connections in a flowthrough configuration, a baffle to further interfere with passage of certain waves from the pump to the system, and a small gas-type dampener, as previously described. Such a device, called a suction stabilizer, was patented several years ago (Figure 18). Additional advantages of a suction stabilizer can be recounted.

Most liquids contain varying amounts of dissolved or entrained air or gas. Since a low pressure area is created in the pump cylinder on the suction stroke, such air or gas will "break out" and create a partial void in the cylinder resulting in low volumetric efficiency. Another demon is the fact that such gases break out of the liquid with greater ease than the reverse—it takes a longer time and higher pressure to redissolve them in the liquid. Consequently, even though the pressure in the cylinder quickly builds up to the discharge pressure on the delivery stroke, some of the gas remains to account for some loss of displacement.

Since a low pressure region exists near the pump inlet, much of the air or gas wants to break out there. If space is provided in the upper part of the stabilizer and the liquid velocity is reduced to give time for good separation (by its large volume), most of this gas will migrate upward and accumulate there instead of proceeding into the pump cylinder. Somewhat the same problem is introduced by liquids having a high vapor pressure. Vapors can break out with the same results.

A secondary, and perhaps more noticeable, effect of air or gas in a suction line is the tendency for the gas to accumulate in small pockets at the high spots in the system. The pockets eventually grow large enough to move through the pump in slugs and cause either momentary or long-lasting airlock with associated noise and knocking. Again, if a sufficiently large internal space is provided in the stabilizer where these slugs of air or gas can accumulate, they will never reach the pump.

What happens to all the gas accumulated in the stabilizer over a period of time? Of course, if there is an excess, it should be bled off through a vent. However, in most cases, the pressure-smoothing ability of the stabilizer minimizes the low pressure

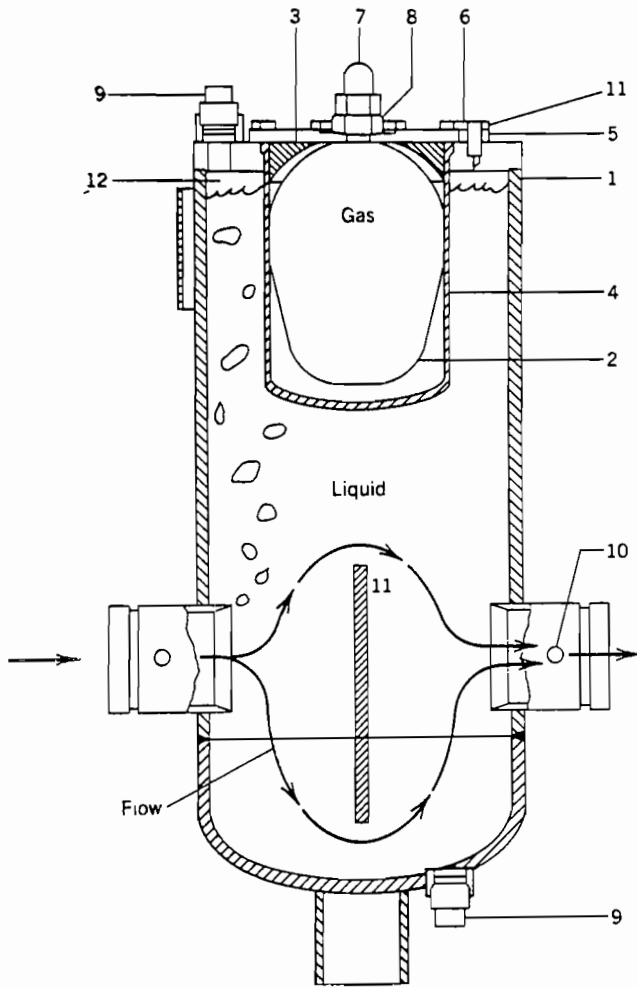

Figure 18. Suction Stabilizer. (courtesy Greer Hydraulics, Incorporated).

disturbances in the pump suction, which in turn minimizes breakout. The small amount of gas will redissolve slowly and consistently and will be carried through the pump without slugging.

Reciprocating pumps are inherently good pressure wave generators. All waves tend to add or subtract to produce undesirable effects and loss of efficiency. Waves produced by one pump can be reflected back on each other to produce the same amplified effect as multiple pumps. As with electrical device such interfering waves can be prevented by the use of simple impedance-transforming devices. In the hydraulic aspect, such transforming can be done by the shape, size, and arrangement of connections and baffles. By flowing through the stabilizer at the pump suction, maximum attenuation of interfering waves, particularly from other pumps in the system, are completely eliminated.

Again, the belief that additional suction pressure alone, provided by a charging pump or by greater head, will negate all of the problems of a "poor" suction system is erroneous. On a long suction line, the source of additional potential energy is so far away from the main pump that its effect is not fully realized because of the time delay encountered. Also, if a centrifugal charging pump is placed close to the main pump, there is little chance for the constant delivery from the charge pump to transform to the varying demand of the main pump. At those moments of the

repeated maximum demand of the reciprocating pump, the "constant" supply of the centrifugal pump may actually act as a restriction. Some fluid "flexibility" must be introduced. In both cases, a properly designed stabilizer will provide the necessary effect. It is evident from the previous discussion that the need for a gas-filled bladder in a suction stabilizer has been played down. The reason for this is the fact that the "large-volume flow-through" feature needed to be stressed. The advantage in the use of a gas-filled bladder is that it provides an energy storing device to take care of the inherent low frequency flow characteristics of a reciprocating pump, and it is most desirable on multiple pump installations. Remember, these are actual flow variations, and can be handled by such a device. As previously mentioned, the large-volume flow-through features are required to control the high frequency pressure wave disturbances resulting from the effects of liquid acceleration disturbances.

Discharge Dampener

The application of gas-filled, bladder-type dampeners (Figure 15) is the generally accepted practice in most applications in "normal" service, particularly where several pumps are discharging into the same system. Normal service would include long pipelines, oilfield water injection, drilling-mud circulation, and process systems with high pressure letdown, etc. Any practical degree of flow-induced discharge pulsation attenuation can be had by proper dampener size selection and by proper gas precharge pressure.

Dampener Sizing

Equations (18), (19), and (20), with constants from Table 4, can be used to calculate the size (volume US gallons) of dampener by inserting the degree of residual pulsation allowed (generally three percent to six percent), and the value of precharge pressure

$$V_g = K_s D_p^2 P_d / T P_c \tag{18}$$

$$V_e = P_{ca} V_{ga} / P_{ca} + P_{cb} V_{gb} / P_{ca} + P_{cc} V_{gc} / P_{ca} \tag{19}$$

$$\Delta P = (1 + A)^2 (P_d + 14.7) - (1 - B)^2 (P_d + 14.7) \tag{20}$$

Table 4. Pump Type Constants

Pump Type	Percent Flow Variation					
	Max	Min	Tot	A	B	K
Simplex SA	58	100	158	0.58	1.0	0.67
Simplex DA	29	100	129	0.29	1.0	0.55
Duplex SA	29	100	129	0.29	1.0	0.55
Duplex DA	24	22	46	0.24	0.22	0.196
Triplex SA	6.0	17.0	23	0.06	0.17	0.098
Triplex DA	6.0	17.0	23	0.06	0.17	0.196
Quintuplex SA	2.0	5.0	7	0.02	0.05	0.030
Quintuplex DA	2.0	5.0	7	0.02	0.05	0.060
Septuplex SA	1.2	2.6	3.8	0.012	0.026	0.017
Septuplex DA	1.2	2.6	3.8	0.012	0.026	0.034
Nonuplex SA	0.6	1.5	2.1	0.006	0.015	0.009
Nonuplex DA	0.6	1.5	2.1	0.006	0.015	0.018

Precharge pressure of a gas bladder-type dampener is the charge of gas, usually dry nitrogen, injected into the bladder through some type of connector and valve. The most desirable precharge pressure is 60 percent to 70 percent of the average discharge pressure or the limit allowed by the bladder design. If the precharge is higher, there is danger of the antiextrusion valve (if so equipped) being destroyed by continual closing on the seat at each pulsation.

A precharge pressure below about 25 percent of the average discharge pressure should be avoided to prolong bladder life by decreasing the degree of flexure. Low-precharge pressure also reduces the effective size of the dampener. With the gas-over-liquid-type dampener, the same sizing calculations can be used as for the bladder type, using a theoretical precharge of 100 percent.

Remember the two basic rules for precharging:

- There should be no pump or system pressure on the dampener during precharge or when checking the precharge pressure.
- The precharge pressure should be about 60-70 percent of the average discharge or suction pressure.

Experiences shows that the high-frequency acceleration generated pulses appearing in a particular discharge system i.e., Figure 10 (a), cannot be attenuated by the use of conventional gas-bladder devices because they cannot react quickly enough to absorb much of the surge. However, again the pump can be fooled for that instant into thinking it is discharging into a close-connected tank. This is done by placing a lumped volume in the form a relatively small vessel close to the pump outlet, in line with the discharge pipe. By placing a gas-filled bladder in such a device (or by providing a gas blanket), the attenuation of both flow and acceleration generated by pulses can be greatly improved. Such a device is being offered by one manufacturer and is shown in Figure 19.

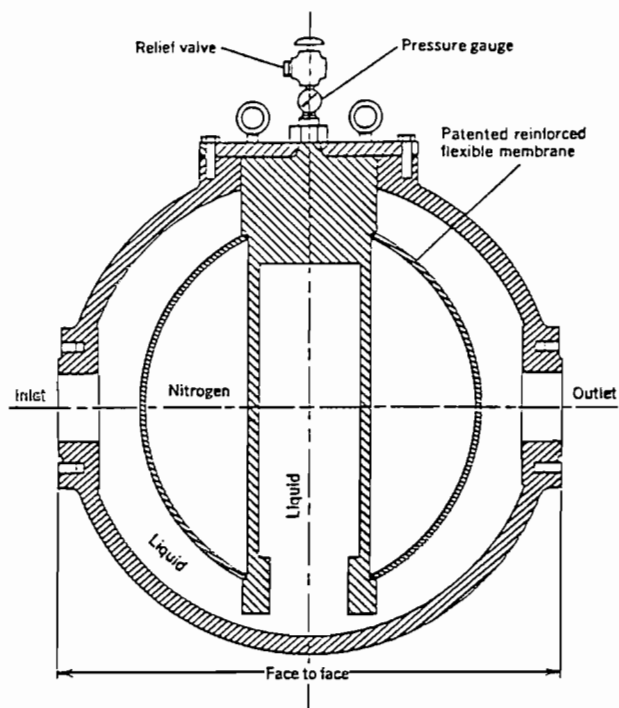

Figure 19. PASAFE™ Dampener.

The trouble-free, gas-bladder type of dampener must be ruled out for the pumps at temperatures above 300°F, because of the high temperature effect on all elastomers, and where there can also be chemical attack on the elastomer bladder. However, the gas or vapor-over-liquid type is just as efficient from the dynamic aspects, and perhaps something can be done to counteract two objections:

- Practical maintenance of proper gas volume.

- Loss of gas by absorption in the liquid.

Objection to maintenance of a gas volume could be overcome by the use of a liquid-level control or continuous injection of hydrogen or other gas as part of a process. The bottle filled with gas would provide the required dampening effect. This would provide much better pulsation dampening than sparging gas into the system downstream from the pump. Of course, continuous introduction of gas in the process would naturally eliminate objection to the continuous absorption of the gas in the liquid. As to the problem of gas absorption by some liquids, the problem is not as severe as first thought. For example, the absorption of nitrogen in water is limited, and some gas-over liquid dampeners at low pressure use an insignificant amount of makeup gas.

As a pump user, one should consider the effect of certain acoustic-type dampeners that impose a back pressure and possible overload on the pump.

Even a plain choke on the pump discharge will provide some attenuation of the pulsations downstream of the choke, but it will impose a higher pressure on the pump.

Multiple Dampeners

For reciprocating pumps in long pipeline service, the use of two or more discharge dampeners (with a total gas volume as required for one dampener) should be considered for the following reasons:

- Since pipeline operating pressure buildup is brought about over a relatively long period (several minutes to an hour or more), there is a period during which the pump pressure is less than the optimum precharge pressure of about 60 percent of the discharge pressure for one dampener. During that time, the pumps would operate without pulsation control. By the use of two dampeners, for example (the second of which is precharged to about half of the first), pulsation control is extended well into the critical startup period.
- In some cases, it is necessary to pump alternate batches of liquids with widely differing viscosities. It is obvious that the pump pressure required to displace the less viscous liquid is less than that for the more viscous—sometimes less than the optimum precharge pressure for one dampener at maximum pipeline pressure. A second dampener precharged to a lower pressure would give protection for a wide range of pipeline pressures.
- The use of multiple discharge dampeners provides some redundancy and protection in case of the loss of precharge or bladder failure in one of the other dampeners. The reason why multiple dampeners are desirable on long pipelines or other applications where there are long periods of operation at various pressures is reflected in Figure 20.

RECIPROCATING PUMP DESIGN

Formulas for calculating the parameters for a reciprocating pump:

$$\text{hhp} = P_d \times \text{gpm} / 1714 \quad (21)$$

$$\text{bhp} = P_d \times \text{gpm} / 1714 \times \text{ME}^* \quad (22)$$

Where ME* = Mechanical efficiency

Single-acting pump, 0.9%

Double-acting pump, 0.85%

$$\text{PRL (single-acting pump)} = 75 \times (3/n') \times \text{bhp} \quad (23)$$

$$\text{PRL (double-acting pump)} = 90 \times \text{bhp} \quad (24)$$

$$\text{PRL} = 0.7854 \times D_p^2 \times P_d \quad (25)$$

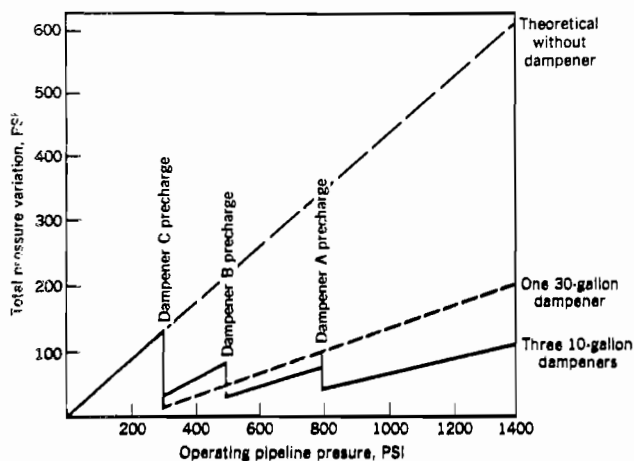

Figure 20. Multiple Discharge Dampeners. 9 × 12 in triplex pump. Maximum operating pressure, 1400 psi.

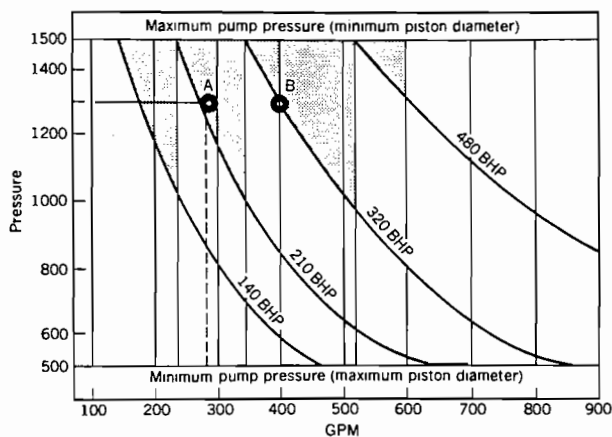

Figure 21. Windows of Nonutilization (shaded area). Performance characteristics of a typical family of reciprocating pumps.

$$\text{Geometric progression; } n, nr, nr^2, nr^3 \quad (26)$$

Where n = basic pump horsepower
 r = Progression ratio

The design specifications of a sample are shown in Figure 22 of a sample calculation for a pump with the following ratings. Typical triplex single-acting of 321 bhp, 1500 psi, 327 gpm and a 24,000 lb prl.

Family Planning

When a series or family of pumps of a certain type is planned by a manufacturer, there should be a scientific and economic method of selecting the size (bhp) of pumps to be included in the family. The geometric progression as approximated below seems to be desirable.

For a family of four pumps, base size 140 BHP:

$$n_1, n_1r, n_1r^2, n_1r^3$$

Where n = basic BHP (140)
 r = progression ratio (1.5)

For example, one manufacturer offers a series of triplex plunger pumps for oilfield secondary recovery (water injection) in the following sizes:

Table 5. Pump Family

$n = 140$	Basic bhp
$n = 140 \times 1.5 = 210$	bhp
$n = 140 \times 2.3 = 320$	bhp
$n = 140 \times 3.4 = 480$	bhp

Windows of Nonutilization

While one reciprocating pump offers a rather wide range of displacement and pressure, economic family planning introduces the negative aspect of "non-utilization." By plotting gpm vs for a family of pumps it will be noted in Figure 22 that there are shaded areas on the chart, called windows of non-utilization, in which each pump must be limited in pressure or displacement. For example, a selected operating parameter, Point A, occurs within the 210 bhp pump allotted position but the 236 bhp requirement in the shaded area forces one to choose the next 320 bhp size, Point B, and accept the penalty of an investment in unusable capacity. (That is one reason why it may be reasonable to consider building pumps of a specific size to suit a large project where many pumps are involved, such as a long slurry pipeline).

INPUT		RESULTS	
DESCRIPTION	: TRIPLEX-SA		
BRAKE HORSE POWER	: 320.000	HYDRAULIC HORSEPOWER	: 288.000
MECHANICAL EFF - %	: 0.900	MAX PUMP SPEED - RPM	: 200.000
NUMBER OF CYLINDERS	: 3.000	PISTON ROD LOAD - LBS	: 24,000.000
TYPE OF PUMP	: 1.000	PISTON ROD DIA - IN	: 1.477
STROKE - IN	: 9.000		
PULSATION RESIDUAL - PSI	: 100.000		
DAMPENER - K	: 0.196		
PISTON SPEED - FPM	: 300.000		
MAX ROD STRESS - PSI	: 14,000.000		

PRESSURE PSIG	FLOW GPM	PISTON IN	VALVE API	DAMPENER GAL
500	987	7.333	8.4	8
600	823	6.694	7.7	8

Figure 22. Pump Design Details.

REFERENCES

1. Miller, J. E., *The Reciprocating Pump; Theory, Design and Use*, New York: John Wiley & Sons(1987).
2. Hicks, E. J., and Grant, T. R., "Acoustic Filter Controls Reciprocating Pump Pulsations," *Oil and Gas Journal*, (January 15, 1979).
3. Wachel, J. S., and Gates, C. L., "Techniques for Controlling Piping Vibration and Failures," *ASME 76-PET-78* (1978).