

CANNED MOTOR AND MAGNETICALLY COUPLED PUMPS APPLICATIONS, OPERATIONS, AND MAINTENANCE IN A CHEMICAL PLANT

by

Helmut Vollmüller

Group Leader

Willi Seifert

Director, Pump Shop

Hoechst AG

Frankfurt, Germany

and

Kenneth B. Fischer

Associate Engineer

Hoechst-Celanese

Houston, Texas



Helmut Vollmüller is a Graduate Professional Engineer. After completing his studies in mechanical engineering at the Technical University at Darmstadt (1956), he joined the Process Technology Department of Hoechst AG, Frankfurt.

He is presently a Group Leader in the Process Technology Department and is responsible for technical supervision of central research. He is responsible for the supervision of process engineering from the

laboratory to the pilot plant. He has many years of experience with sealless pumps of all types in the pilot plant, and with their application to full scale facilities.



Willi Seifert is a Graduate Professional Engineer. Mr. Seifert joined Hoechst AG in 1953 and has been active in the technical sections of the Maintenance Department. Since 1979, he has served as Manager of the Pump Shop at the Hoechst plant. He is the prime contact for the plant concerning all pump questions. He also directs the repairs and testing as well as the central pump warehouse.



Kenneth B. Fischer is an Associate Engineer with Hoechst/Celanese. He is a graduate of the University of Houston in Mechanical Engineering (1960). Mr. Fischer joined Celanese in 1963 as a Project Engineer. In 1967, he began work as a Rotating Equipment Maintenance Engineer. He is now a Corporate Rotating Equipment Consultant working out of the Corpus Christi Technical Center for the Mechanical Technology group. Mr. Fischer is a Registered Professional

Engineer in Texas and a member of ASME.

ABSTRACT

The environmental requirements that drive chemical producers to move more and more to the use of the "sealless" pump are described. The development of the sealless pumps in the European industrial community and their application in various chemical services is traced. More significant developments are enumerated in the areas of design and materials as applied to this complex problem. Finally, a summary of the successes and failures of the sealless pump in various services are documented.

The term sealless pump applies to the canned motor pump and the magnetic drive or magnetically coupled pump. Both of these designs are discussed along with their relative merits. The sealless pump was developed specifically to totally eliminate the need for a mechanical sealing system. The mechanical seal, by its very design must, leak to survive and this feature is not acceptable in certain liquid services.

The driving force behind this development was originally the handling of toxic (lethal) or pyrophoric, flammable liquids. This technology has, in recent years, found a new more formidable champion in the almost universal concern for the environment and in the governmental legislation relating to those concerns.

INTRODUCTION

Centrifugal pumps, in particular normal chemical pumps that comply with DIN 24-256 or ISO 2858, are the most important and widely used process equipment in the chemical industry. In the USA, the equivalent pump standard is ANSI B 73.1 1991. On pumps complying with these standards, the dimensions and hydraulics are standardized to allow interchangeability among manufacturers. Pumps equipped with packing or mechanical seals have a system-dependent weakness. Because of the rotary motion of the shaft, the product, by design, leaks through the packing or across the seal faces.

In Germany, the regulations governing safety in the work place, and laws enacted for the protection of the environment, have become considerably more stringent. Product leakage around equipment is no longer tolerated. Accordingly, pump manufacturers and users must pay particular attention to leak points such as shaft seals and flanges.

The conventional mechanisms to seal shafts have been optimized and greatly improved over the last decade. However, even these sealing systems must leak if they are to survive.

Stuffing boxes with packing also have a function-dependent leakage and are prone to misuse, such as over tightening or under tightening. Mechanical seals typically have minimal leakage associated with them, but again they must leak, if the faces are to survive. Even double mechanical seals require a contained barrier fluid-seal flush system with some "inert" liquid to avoid leakage of the product. Even careful selection of the barrier fluid will not always eliminate seal damage, which in turn leads to loss of production. On either system, the leakage rate increases with normal wear and tear with emphasis on tear, because ordinary wear does not occur very often.

The susceptibility of seals to leakage, and the increasing requirements on safety and the environment in recent years in Germany, have led to the development of hermetically sealed pumps with the power transfer accomplished by means of permanent magnets or electromagnets.

Today, users rely on pumps driven by magnetic couplings or motors enclosed in the pressure containment space occupied by the pump itself.

GOVERNMENT REGULATIONS

Two examples of German regulations will be used to illustrate the necessity for the development and use of completely leak free drives for pumps. To protect the health of the worker in the work place, values of the "mak" (maximum allowable work place concentration) [1] for poisonous, very poisonous, and carcinogenic fluids, have been established. The "mak" values are typically as low as a few ppm and can, in some cases, be as low as 0.1 ppm.

The "mak" value for hydrogen fluoride, for example, is 2.0 mg/m³. If a pump leaks liquid hydrogen fluoride at a rate of 1.0 cm³/hr the HF will evaporate, and, assuming the volume boundary around the pump is 5.0 meters by 5.0 meters by 3.0 meters, and assuming a 5-fold air change, the HF concentration will be 2.67 mg/m³, which obviously exceeds the "mak" value.

For environmental protection from emissions, the German supervisory body Ta-Luft [2] requires that organic compounds of their Class 1 (such as phenol, acrylic acids and acrylate compounds, formaldehyde, amines, chlorinated hydrocarbons, formic acid, etc.), for flowrates of over 0.1 kg/hr or more, comply with a mass concentration of 20 mg/m³ or less for the entire plant. In order to achieve this requirement for the entire plant, it is necessary to use every opportunity to avoid emissions.

The text of the Ta-Luft agency [3] covering the conveying of flammable liquids and liquid organics states that, depending on classifications, (even for low concentrations, e.i., 10 mg/kg of Class 1 components) special measures have to be taken to reduce emissions. These measures include the use of double mechanical seals and sealless pumps.

CONSTRUCTION OF MAGNETICALLY COUPLED PUMPS

The basic construction of a magnetically coupled pump is shown in Figure 1.

The impeller, shaft, bearings, and inner magnets are in contact with the product. The product is contained within the "can" or shell which is normally made of thin wall alloy metals, ceramic, or some type of plastic material which is nonmagnetic.

In contrast to conventional drives, there are no shaft seals. The system transfers torque by means of the magnetic flux of magnets contained in the rotor outside the can to the magnets in the rotor inside the can.

The most commonly used magnets today are rare-earth samarium-cobalt permanent magnets (i.e., SmCo5). These magnets are applicable for service temperatures ranging from -190°C to +220°C. They also tend to resist the demagnetizing effect caused by the

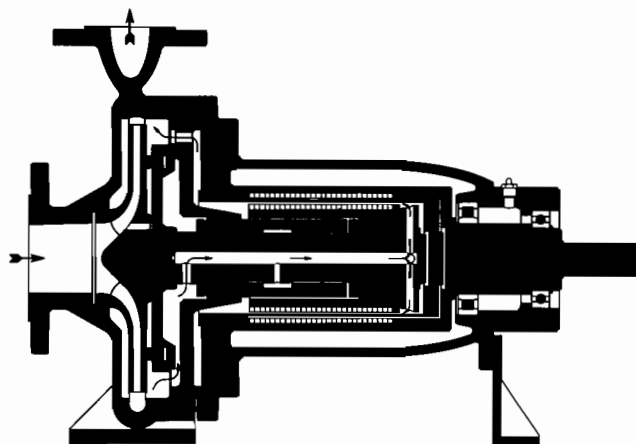

Figure 1. Typical Mag-Drive Pump.

decoupling of the rotors on overload. When temperatures exceed 220°C to an upper limit of 450°C, the magnet material is typically changed to Al-Ni-Co.

CANNED MOTOR PUMPS

The canned motor pump (Figure 2) has been around for about 70 years. However, widespread practical use did not begin until the 1950s, when safety and environmental issues initiated the trend towards absolutely leak free pumps. In this type of pump, the motor and the pump hydraulic parts are contained in a hermetically sealed case. The impeller and the pump rotor are both attached to a common shaft. A thin walled shell separates the motor stator from the rotor in a similar manner to the magnetically coupled pump, and for the same reasons. The rotor has to be supplied with a stream of cool, reasonably clean fluid, normally the product or pumped fluid. This is required to lubricate the bearings and to remove the heat generated by the motor. It is also required in most cases to assist in the matter of balancing the thrust forces in the rotor system. This stream is often taken from the discharge of the pump and sent to the rotor section, depending upon the pump size, via an external line or through internal ports.

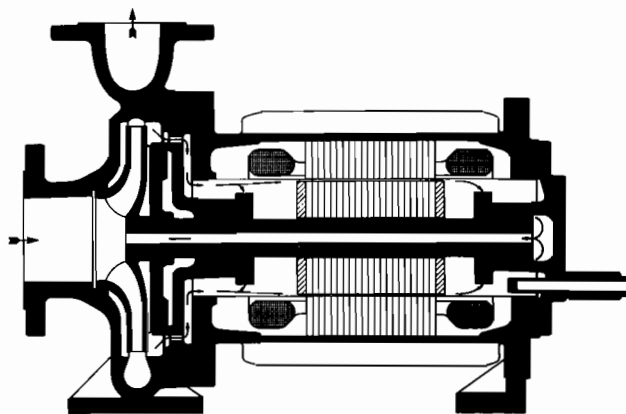

Figure 2. Typical Canned Motor Pump.

The advantages of both types are:

- Absolutely no leaks to the atmosphere under normal operation.
- A high degree of safety and environmental friendliness.

Additionally for canned motor pumps:

- Maintenance-free relative to sealed pumps.
- Quiet operation.
- Very compact with smallest space requirement.
- Low installation cost because neither foundation nor base-plate is required.
- Safe from emissions even when the can is breached, because the stator can withstand and contain the product liquid for a short period of time.
- No ball bearings.

The additional advantages of magnetic drive pumps are:

- No special explosion protection certification or permit is necessary.
- The mag-drive pump can be substituted for the DIN or ANSI pumps without major modifications. The authors do not consider the standard electric motor an advantage. Experience would indicate that the canned motors are not a problem. The maximum power attainable at this time stands at about 300 KW or 400 hp for canned motor pumps and just over 100 hp for mag-drive pumps.

TECHNICAL DETAILS OF THE DRIVING MECHANISMS

The enclosed construction of both types limits the choices and sizing criteria of the bearings which are required to run in the pumpage or pumped fluid. In most cases, the pumpage has very poor lubricating properties and may or may not be corrosive. During operation with an established hydrodynamic lubricating film, there is no contact between the bearing surfaces. This results in very long bearing life; for example, in refrigeration units, up to 65,000 operating hours pumping ammonia have been achieved using canned motor pumps.

Several low-friction pairs of bearing materials are used, such as:

- Hard chrome or chrome-oxide against hard carbon.
- Hard chrome against zirconium oxide.
- Silicon carbide against silicon carbide.
- The combination of silicon carbide against silicon carbide with a maximum concentration of 0.01 percent of free silicon that can be used almost universally.

Some manufacturers apply a layer of carbon on the SiC bearing surfaces to permit short periods of "dry running." However, experience says that it only allows dry running one time and then, as the manufacturer suggests, only a short duration. It is very important that the pump be installed in such a way that running dry is totally avoided, and that the pump can be totally degassed prior to startup.

Because magnetic fields are intercepted when moving across the metallic shroud or can, electrical eddy currents are produced which result in heat being generated in the can material. The amount of heating depends upon how magnetic the can material might be. Hastelloy is normally used in mag-drive pumps rather than austenitic stainless alloys, because the former has a lower iron content. In a 40 KW drive, these losses may be as high as 5.0 KW. The heat thus generated must be carried away to prevent overheating the drive, or in some cases, the product if it is heat sensitive. Plastic and ceramic shrouds or cans are completely nonmagnetic and, therefore, do not exhibit this behavior. The material combinations will depend in large part upon the both fluid properties and operating conditions. There is a large variation in the design of the cooling system or method from one manufacturer to another, and therein lie most of the differences.

In mag-drive pumps, and in canned motor pumps, limits with respect to the pumped fluid must be observed. At low flowrates, the heat input attributable to operating away from the best efficiency point and also the motor heat are not always effectively removed. The fluid may then evaporate and the pump will risk running dry. The minimum flow through the pump is dependent upon the vapor pressure, as well as the specific heat of the fluid being pumped. For high flowrates, the pressure necessary to maintain cooling flow may not be sufficient or the flow may get interrupted due to cavitation. It should be noted that the heat generated by the magnetic field can become excessive when the coupling is operated too far out on its power curve.

Both types of sealless pumps are susceptible to potential problems due to low or high viscosity. In the case of low viscosity, the lubricity of the product may be too low for proper lubrication of the bearings. When the viscosity is too high, heat generated due to friction loss of the liquid in contact with the rotor can become excessive. The viscosity range normally acceptable is from 0.1 To 20 centipoise. For special designs, the viscosity may go as high as 120 centipoise.

Special attention during the design and manufacture of both types of sealless pumps must be paid to the elimination of axial forces that are largely a result of the poor lubrication available at the thrust bearings.

One example of the load reduction achieved through the design of an "automatic thrust equalizer" of one manufacturer [4] is described in Figure 3.

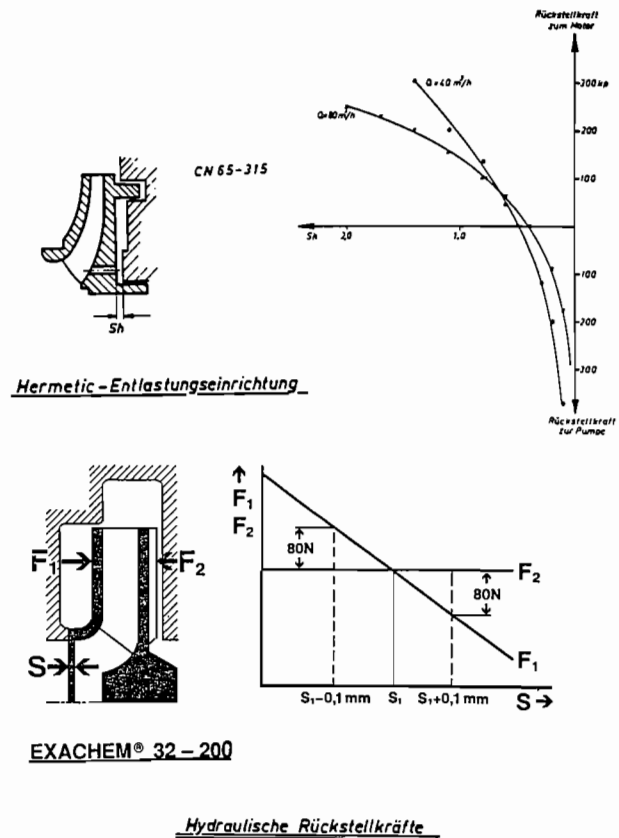

Figure 3. Specific Construction of a Mag-Drive Pump.

Here, an equalization chamber is located on the backside of the impeller, which is fed high pressure pumpage from the area near the discharge by means of an annular orifice formed by the outer ring in the groove. This ring and groove combination acts as a

throttling device to regulate the pressure of the fluid in the chamber. The holes in the center of the impeller, which are typically used as balance holes, cause the impeller to be balanced against the suction pressure and flow of the fluid. Several API manufacturers use a similar design to reduce the thrust loads on their bearings.

Experience demonstrates that the disadvantage to this type of thrust equalization is, it is limited to a narrow operating range. If the pump is to be operated in a completely different range, it may have to be readjusted on the workbench and the balance holes changed accordingly.

Another manufacturer [5] has introduced an interesting new design for canned motor pumps that eliminates the need for thrust bearings. It is accomplished through an axial regulating gap on the suction side eye ring between the ring and the housing (Figures 3 and 4). Thrust balancing is further aided by pumping vanes on the backside of the impeller. The force on the suction side of the impeller is equalized by a counter force from the backside of the impeller. The axial forces are, therefore, hydraulically equalized over the entire range of the pump curve.

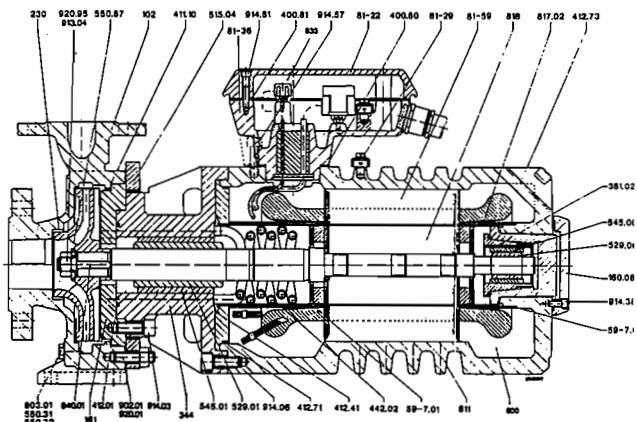

Figure 4. Mag-Drive Pump with Plastic Components.

As far as materials for either type pump are concerned, all currently available metals can be used. Designs using the more expensive materials such as zirconium, titanium, etc., have been applied. The cans, or separating shells, are almost exclusively made of materials that have the lowest possible magnetic properties. Several manufacturers are using plastics, and in some cases, the mag-drive can is made of ceramics such as zirconium oxide.

SPECIAL APPLICATIONS

The applications for sealless pumps are predominantly for aggressive, poisonous, volatile, flammable, odorous, and/or expensive liquids. They are also used for low vapor pressure liquids, explosive materials, and for high pressure applications. Special canned motor pumps are used in high pressure services, extremely low temperatures, and for low noise applications. Special applications and the peculiarities of the designs will be described next.

HIGH TEMPERATURE OPERATION

For higher temperature pumpages (150°C to 400°C) in either type of sealless pump (Figure 5), the hydraulic part of the pump is separated from the drive section by an intermediate seal or bushing to avoid overheating the drive. The pressure equalization between the pump and the drive is accomplished via a restricting nozzle or orifice. Cooling for the drive area is achieved by means of a secondary impeller that circulates the liquid through an external

cooler. Temperatures of 60°C to 80°C can be realized by this technique.

In canned motor pumps, it is possible to operate motors at temperatures up to 400°C without external cooling, if the motor is equipped with cooling fins and special windings.

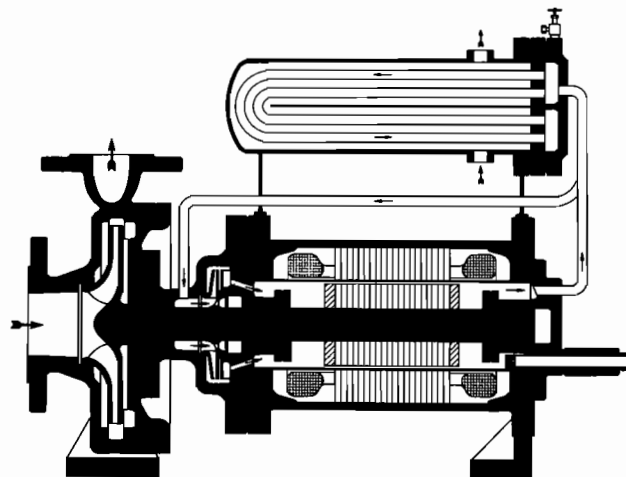

Figure 5. Thrust Balancing Techniques.

SLURRIES

To pump slurries, pumps can be equipped with separate cooling loops and the addition of a pure barrier fluid as a flush into the hydraulic section of the assembly (Figure 6). The amount of flush depends upon pump size and operating conditions; it can range from one to 10 liters per hour.

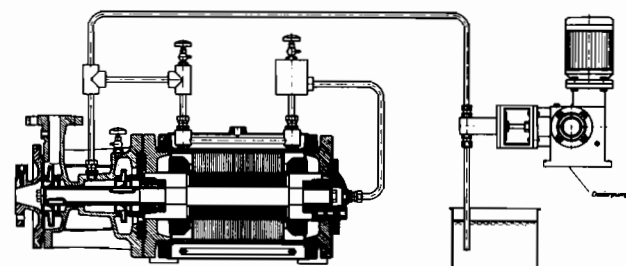

Figure 6. Modern Canned Motor Pump-Isolated.

LIQUID GASES

In normal shaft sealing systems, the risk of forming ice when leakage occurs must be considered when pumping liquid gases, since ice will sooner or later destroy the sealing surfaces (Figure 7). For this reason, canned motor pumps have found a lot of applications in this area (i. e., LNG pumps in ships, pipeline, and storage systems). The biggest problem with these applications is from cavitation or flashing of the liquid, particularly if the pump operates near the boiling point of the liquid. The following precautions should be taken to alleviate these concerns:

- In multistage pumps, the slip stream for cooling after passing through the pump is not directed to the suction of the next stage, but to an area of higher pressure between subsequent impellers.
- In single stage pumps, the cooling/lubricating stream on the pressure side of the pump is taken off through a screen filter, passed through the inner rotor, and recycled to the high pressure

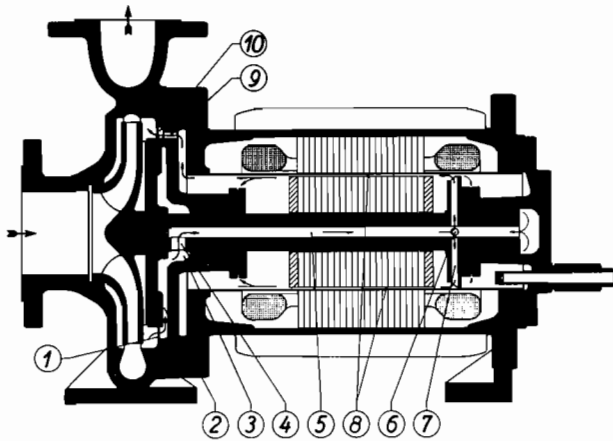

Figure 7. High Temperature Pump.

end of the pump. A secondary impeller in the drive section overcomes the pressure drop.

HIGH PRESSURE APPLICATIONS

In applications at pressures over 1,500 psi, the use of conventional circulation pumps becomes very difficult because of the seals (Figure 8). This also applies at much lower pressures with high temperature boiler feedwater, i.e., 900 psi and 550°F.

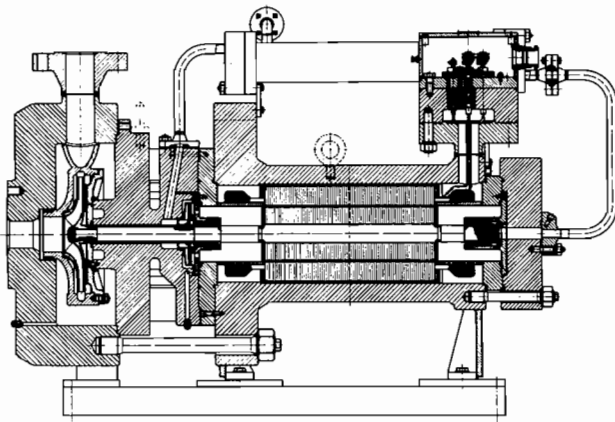

Figure 8. Pump System for Handling Slurries.

Canned motor pumps designed for such high pressures have pressure containing cases capable of withstanding these pressure requirements.

To support the can of the motor against the high internal pressure, the stator coil itself may be expected to act as a pressure carrying unit. The grooves which guide the windings are moved a little further out radially to make room for the parts that support the can between the stator packet and the motor closure. A pump designed for high temperature and pressure services is shown in Figure 9.

Among the many feasible applications, it should be mentioned that sealless pumps can also be designed for self priming services, parallel operation, miniature geometries, etc.

EXPERIENCE AND COST OF OPERATION OF SEALLESS PUMPS IN A CHEMICAL PLANT

In the last section experience with both types of sealless pumps in a large chemical plant [6] is presented.

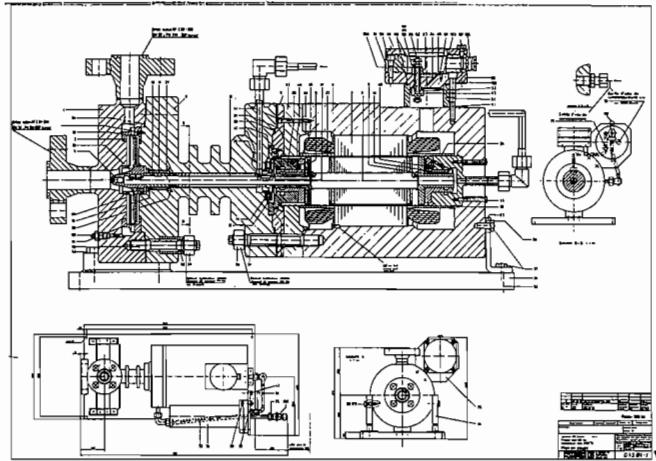

Figure 9. Canned Motor Pump for Liquids Near Boiling.

There are approximately 27,000 pumps in the referenced plant. This number does not include drum pumps, hand pumps, or laboratory pumps. Forty-two percent of these pumps are chemical circulating pumps. In 1991, 79 percent of the population were standard chemical pumps equipped primarily with double mechanical seals, 11 percent were canned motor pumps, and 10 percent were magnetically coupled pumps. 70 percent of these 2,700+ pumps were metallic construction and 30 percent were plastic. As a comparison, the numbers in 1984 were 88.5 percent standard chemical pumps, 10 percent canned motor pumps and 1.5 percent mag-drive pumps.

A clear trend can, therefore, be seen toward the increased use of sealless pumps and to mag-drive pumps in particular.

When considering the large increase in the number of mag-drive pumps, it should be realized that the primary development and market availability just took place within the past ten years, while canned motor pumps have been available for a much longer period.

Sealless pumps are used in all areas of the plant to pump toxic substances, flammable, inorganic, and organic chemicals, acids, bases, solvents, and hot water in high pressure heaters. A few examples of the applications of mag-drive and canned motor pumps are listed in Figure 10.

Pump operating experience, failures, and maintenance performed are registered and analyzed on computers. The statistical information thus collected is passed on to the various plants within the organization. Typical causes of damage are presented in conjunction with attendant cost considerations.

EXPERIENCE AND COSTS

Having mentioned the advantages in technological, safety, and environmental features of the designs, the understandably pertinent question of costs can now be addressed.

In Figure 11, the average investment costs of the three pump types are given for three levels of driver power.

For pumps in the lower power ratings, it can be seen that, for normal chemical pumps, the large amount of money expended on double mechanical seals and associated seal flush systems is very significant. When power ratings increase, the cost of larger magnets and the expense of manufacturing large canned motors becomes the dominant factor. As previously mentioned, the cost of installing the different types of pumps should also be considered. The canned motor pump will be the least expensive to install.

When considering operating costs, the cost of electric power is considered first. Because of turbulence and/or frictional losses in canned motor pumps and in mag-drive pumps, the following average or normalized costs for electric energy are presented.

Medium	Temperature	Material	Pump Type M=Mag-Drive S=Can-Motor
Ammonia	-50 C/ 40 C	GGG-38/1.4581	S
Chlorine	-35 C/ 40 C	GGG-40/1.4581	S
Dimethylsulphate	80 C	SSS	S
Acetic Acid 80%	60 C	1.4581	S,M
Acetic Acid 96%	105 C	Hastelloy C	S,M
Ethylene Oxide	40 C	1.4581	S
Hydrofluoric Acid	40 C	1.4581	S
Hydrocarbons	-70 C/ 30 C	1.4581	S
Hot Water	200 C	GGG-40	S
Lime Slurry	60 C	1.4581/1.4408	S,M
Solvents	160 C	1.4581/1.4408	S,M
Monochloroacetic Acid	20 C/140 C	Hastelloy C/ PTFE	S,M
Potassium Carbonate	80 C	GGG40/1.4581	S,M
Chlorobenzene	80 C	1.4581/PTFE	S,M
Propylene	-10 C/ 40 C	GGG-40/1.4571	S
Chlorinated Acids	100 C	Hastelloy B	M
Hydrochloric Acid 33%	40 C	Hast.B/PTFE/ PVDF	S,M
Sulphuric Acid 70%	115 C	PTFE	M
Sulphur Trioxide	40 C	1.4581	S
Heat Transfer Fluids	350 C+	GGG-38/GS-C25	S,M

Figure 10. Canned Motor Pump for High Pressure.

	2.5 kW	8 kW	50 kw
Standard Chemical Pumps w/Double Mechanical Seals	1	1	1
Mag - Drive Pumps	0.75	1	1.35
Canned Motor Pumps	0.8	1	1.1

Figure 11. Canned Motor Pump for High Pressure and Temperature.

- Standard chemical pumps w/double seals 1
- Mag-drive pumps w/plastic can ~ 1
- Mag-drive pumps w/ceramic can ~ 1.08
- Mag-drive pumps w/metal can ~ 1.11
- Canned motor pumps ~ 1.19

A considerable portion of the overall operating cost of pumps is governed by repair costs. The typical failures peculiar to the three types of pumps are listed for comparison. The main components susceptible to damage in the standard chemical pumps are found in the stuffing box. Here, the packing or the static seals (O-rings) have to be replaced frequently. Double mechanical seals require a system including a tank and some means to circulate the flush liquid through the seal cavity (i.e., thermosyphon, pumping rings, or pumping screws).

The liquid in the tank must be maintained at the proper pressure and level or the seals will fail for lack of lubrication. Failures here are generally caused by inattention.

In magnetic pumps, the main cause of failure is in the sliding bearings. Damage to the bearings is usually caused by operating above or below the optimum flow range of the pump (i.e., Q_{min} to q_{max}). This is caused by liquid flashing in the drive area of the pump which results in the bearings running dry.

In mag-drive pumps with plastic cans, solids in the pumpage can result in abrasive damage to the housing, the impeller, and/or the

can. Such damage can be relatively expensive as compared to the all metal pump construction.

The causes of failure of 185 magnetically coupled pumps in a nine month period are shown in Figure 12.

DAMAGE EVALUATION OF MAGNETIC PUMPS

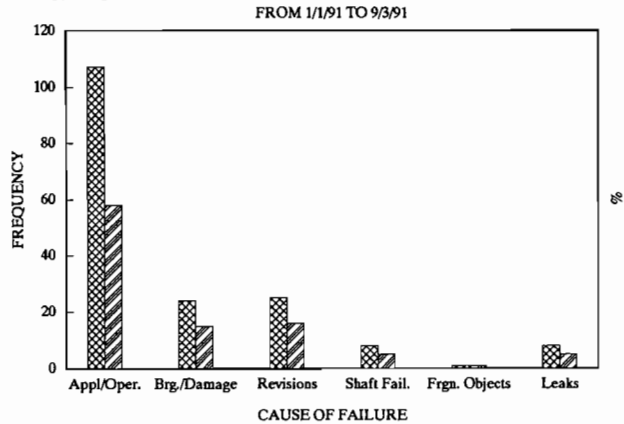

Figure 12. Applications for Mag-Drive and Canned Motor Pumps.

The largest contributor to failures in that group was wrong operating conditions, with 58 percent of the events attributed to this category. Among the conditions were bad application, operator errors, operating outside the Q_{min} to Q_{max} range, not filling the pump with liquid before starting, and large amounts of solids in the pumpage.

Fifteen percent of the failures were defective or failed ball bearings in the driving half of the magnetic coupling. These failures were generally caused by water splashing from wash downs. These can be avoided by better sealing. Sixteen percent of the failures were caused while work was being performed on the pumps. The remaining 11 percent was damage to shafts, leaking flanges, and damage caused by foreign object ingestion.

Overall, canned motor pumps experienced the lowest failure frequency of the three types. The predominant damage here was again caused by operating outside of the optimum operating range of the pump, and subsequent dry running resulting in bearing failures. Many of these pumps have operated for such long periods of time that a varnish-like material was built up on the rotor of the canned motor. On the older pumps, some shaft failures were experienced as a result of embrittlement of the isolation can.

In Figure 13, the cost of a single repair, the repair frequency, and the repair cost factor from the product of cost times the frequency of repairs is shown for the three pump types. The canned motor pump appears to be the most cost effective. Considerable improvement potential exists, however, in the mag-drive pump if the previously described damages due to improper operation can be avoided.

	Normalized Ordinary Repair Cost	Repair Frequency - %	Repair Cost Factor - CostxFreq.
Standard Chem Pumps w/ Double Seals	1	20.7	0.21
Mag-Drive Pumps	1.75	20.2	0.35
Mag-Drive with Improved Maint.	1.75	8.5	0.15
Canned Motor Pumps	1.3	7.1	0.09

Figure 13. Normalized Cost of Investment. Sealless vs standard.

The cost breakdown for repairs made in the 1987 to 1991 time frame is shown in Figure 14. Aside from rising costs in the aforementioned time span, the change in the distribution between labor and material costs should be noted.

	Cost Increase		Cost Distribution			
	Cost Factor Single Repair		Salary Costs		Material Costs	
	1987	1991	1987 %	1991 %	1987 %	1991 %
Standard Pumps	0.9	1	69	38	31	62
Mag-Drive Pumps	1.3	1.75	71	26	29	74
Can-Motor Pumps	1.3	1.3	66	35	34	65

Figure 14. Failure Distribution for Mag-Drive Pumps.

For standard chemical pumps, more stringent environmental regulations in Germany play an important role in the increased rate of converting from single to double mechanical seals. In magnetically coupled pumps, the increased use of plastic pumps has resulted in corresponding increases in repair costs. Finally, for canned motor pumps, such failures as are currently seen in shafts and cans are the result of long term operation.

The rise in the number of mag-drive pumps at this facility from 1984 to 1991 is depicted in Figure 15. Failures have been reduced in the past year after being somewhat constant for the previous four years. This is probably the result of a more detailed investigation

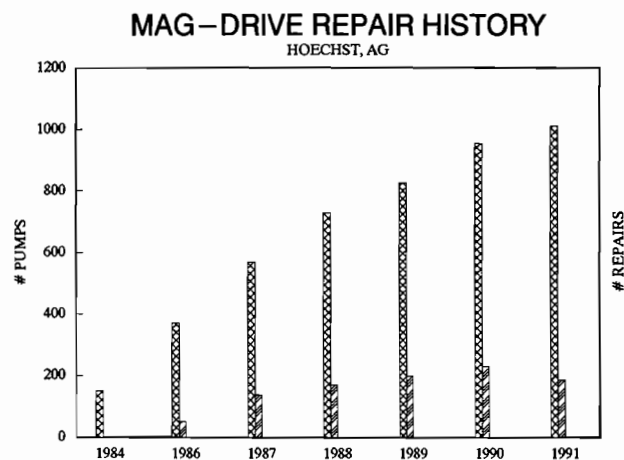

Figure 15. Repair Cost Breakdown. Standard vs sealless pumps.

of the causes of failures, coupled with increased training of plant personnel.

It is reasonable to conclude that sealless pumps of either type are reliable and cost effective when their design, installation, and operation are all performed with proper care. It is very important in the design phase to select the proper pump and to equip it with the proper support and protection equipment. The existing canned motor pumps have long used temperature monitors and dry run protective devices, such as low current relays. Both of these protective devices are recommended for all sealless pumps.

The following supervisory instrumentation is strongly recommended:

- monitor can and/or motor temperatures
- leak monitoring for double canned motors (i.e., plastic pumps)
- monitoring of the liquid in the suction piping
- monitoring of the pumpage (Q_{min} to Q_{max})
- monitoring of the motor load

The application of these protective devices is probably product dependent and may require one or all of the devices mentioned. The point is to think about the application.

The intent herein was to present an overview of the current state of technology, typical applications, and the long term experience with sealless pumps in a chemical plant environment. Clearly then, these pumps can be used to solve fundamental problems with respect to work place and environmental protection, while being maintenance friendly and cost effective.

REFERENCES

1. "Maximum Workplace Concentration and Biological Material Tolerance Values," Published by the Senate Committee of the German Research Committee for the Testing of Health Hazardous Working Material.
2. Ta-Luft: "First Overall Regulation for the Federal Emissions Protection Law: Technical Introduction to the Protection of the Air."
3. VBF Regulation for Flammable Liquids.
4. Kraemer, R. and Neumaier, R., "Centrifugal Pumps and Rotary Positive Displacement Pumps of Hermetic Design," Company publication of Hermetic-Pumpen GmbH, Gundelfingen.
5. "The New Exachem," Company publication of KSB AG, Pump Division, Pegnitz
6. Experience of the pump section at the Hoechst plant of Hoechst AG.