

## Bearing Maintenance Practices to Ensure Maximum Bearing Life

Brian P Dahmer  
Manager, Application Engineering  
SKF USA Inc.  
Lansdale, PA USA



Brian Dahmer is currently an Application Engineering Manager at SKF USA Inc. working out of SKF's Lansdale, PA headquarters. His group's area of responsibility includes providing technical support to many of the major fluid machinery companies including pump and compressor manufacturers. Brian personally calls on many of the key pump manufacturers. Over his 27 years with SKF, Brian has extensive experience with many bearing applications including pumps, power transmission and paper/printing machinery. In the past, Brian was also responsible for conducting the MRC Pump School, which focused on providing practical pump bearing knowledge for pump users and others interested in a deeper understanding of the subject. Mr Dahmer is a graduate of Lehigh University with a Bachelor of Science degree in Mechanical Engineering.

### Abstract

Reliability of centrifugal pumps is heavily dependent on bearing reliability. The bearings that support the impeller shaft are complex machine components whose service life is directly affected by:

- Contamination (both particulate and water)
- Lubrication method and lubricant type
- Mounting and dismounting techniques
- Selection of components
- Control of inactive bearing rolling elements
- Proper housing support and alignment

In addition, there are major risks to bearings from unexpected loading conditions as well as exposure to vibration while idle. The effects of these conditions and how to avoid the risks need

to be considered in order to maximize service life.

Lastly, condition monitoring is an excellent way to maintain awareness of the health of bearings. However, even the best condition monitoring tools and techniques are of little value if not implemented and interpreted correctly.

### Introduction

Rolling element bearing reliability is key to pump reliability. Without the ability for the impeller shaft to rotate accurately and smoothly, a centrifugal pump cannot perform its desired function. Today's bearings are marvels of engineering and manufacturing. While many will complain that bearings are very costly today, however when compared to bearing prices from a century ago (adjusted for the value of money), today's bearing prices are quite inexpensive. This is especially true when the precision level of the bearing is looked at. Today's angular contact ball bearings and deep groove ball bearings typically used in centrifugal pumps have dimensional and running accuracy tolerances that are measured in ten thousandths of an inch (a few microns) and raceway surface finish tolerances measured in millionths of an inch (less than 1 micron). The materials used in today's bearings are also much cleaner and stronger than bearings from decades ago. So, today's rolling element bearings are highly engineered precision pieces of machinery capable of operating in demanding conditions for long periods of time. However, bearings can only function reliably when the entire rotating system and adjoining components are operating as designed.

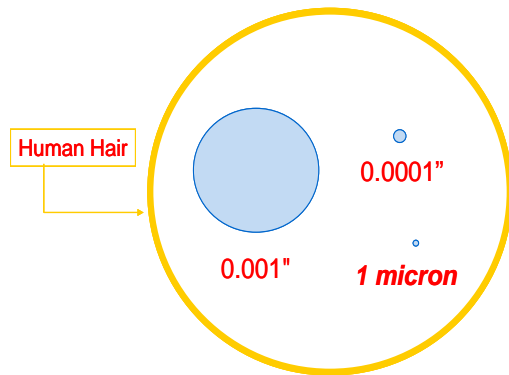

Figure 1. How small is one micron? Bearing tolerances are typically just a few microns.

While a bearing may be more durable today than it was decades ago, it is still part of a system and is dependent on the other parts of the system for reliability. Oxidized, inadequate or contaminated lubrication can dramatically shorten bearing life. Shaft deflection can also dramatically reduce bearing life. Seal performance, particularly the bearing housing seals, can affect bearing performance as well. In order to maximize bearing life, the entire system must be examined.

### Contamination

While bearings are made of hardened steel, they are surprisingly susceptible to contamination. The reason is the very high contact pressures that are present in the small contact zones (see Figure 2) between the rolling elements and the raceway. Pressures of around 200,000 psi between the ball and the race in an angular contact ball bearing are not uncommon. Over-rolling contaminant particles with such high contact pressures results in dents in the raceway.

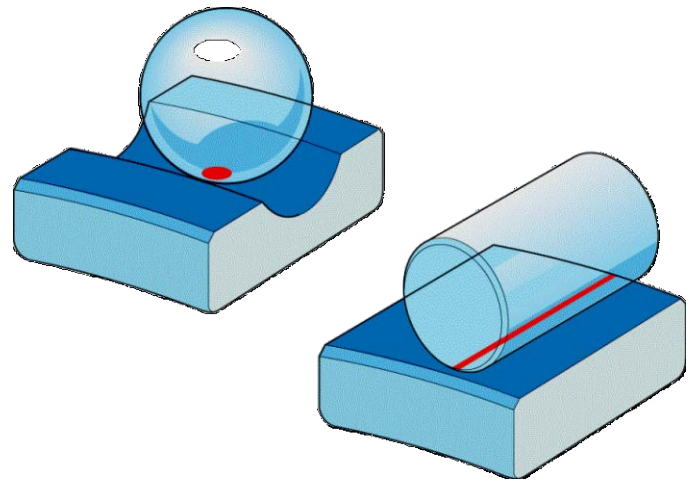

Figure 2. Contact areas for ball and roller bearings endure very high pressures.

Particulate contaminants, whether those particles are soft or hard, large or small, will cause some damage to bearings. Even polymer particles, though quite soft, will extrude when over-rolled and cause large but shallow dents (see Figure 3, bottom photo). Harder particles create smaller but sharper dents (see Figure 3, top photo). All of these dents are detrimental but the harder the particle, the sharper the dent and the higher the stress concentrations at the edges. Therefore, typically, hard particle contamination is more damaging than soft particle contamination. Both types of particles still do damage so keeping the bearings clean during installation and operation is critical to avoid both denting and wear.

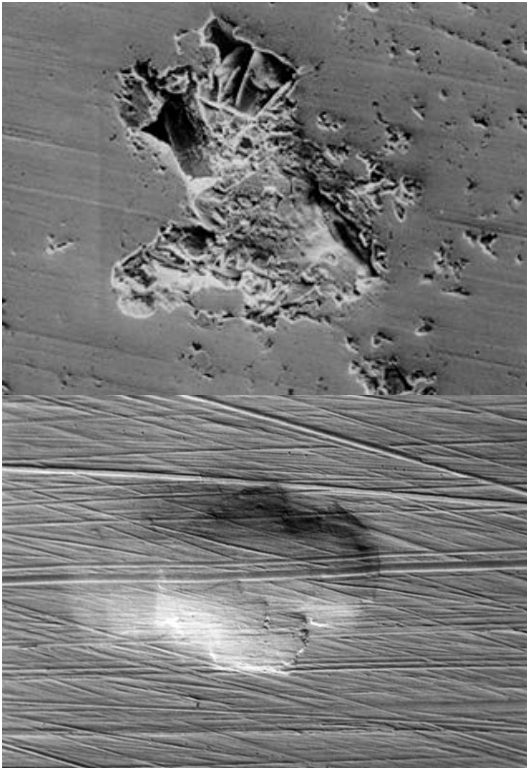

Figure 3. Hard particle dent (top) and a soft particle dent (bottom) can both be damaging

The presence of contamination shortens bearing service life in two ways. Every time a rolling element passes over a dent, contact pressure increases at the edge of the dent. Higher stresses result in shorter fatigue life. The second mechanism is wear. While balls do roll in a ball bearing, due to the curvature of the balls and races, there is some sliding that occurs as well. The sliding portions of the contact, when contamination particles are present, can result in wear of the surfaces. Roller bearings can also exhibit wear from contamination but this wear may be in different places such as the ring flanges in addition to the raceways.

When bearings are being installed, they should be left in their original package as long as possible and only unwrapped just prior to being put on the shaft. If they have been unwrapped, they should be covered with their original wrapping or a clean, lint free cloth to keep dust and airborne dirt from coming into contact with the bearing. Likewise, once installed on the shaft, the bearings should be covered or wrapped to keep contamination away from the bearing. Also,

use clean tools as well as clean gloves and rags when handling and installing bearings. Other components such as the bearing housing, the shaft, oil rings and seal components should also be cleaned prior to bearing installation.

Once installed, lubrication must be clean as well. Make sure that oil or grease containers are not left open to the air so that they may pick up contaminants. Funnels and other items used to introduce oil into the housing should be cleaned as well so that particles adhered to them are not introduced into the housing.

Sealing of the bearing housing is critical to prevent the ingress of contaminants. Seals should be appropriate for the operating conditions and should be designed to prevent entry of all types of contaminants into the bearing system. The two types of seals typically used are lip type contact seals and labyrinth seals. Lip seals, typically made of rubber lips encased in a sheet steel shell or case; provide excellent protection from external contaminant. However, the seal lip contact with the shaft must be lubricated and, even with lubrication, the seals do create added frictional heat.

Seal lips also wear. Depending on conditions, the seal lip may fail well before a bearing fails. Seal failure will likely lead to bearing failure. Once signs of seal leakage are present, taking the time to replace lip seals promptly may reduce the frequency of bearing failures. If seals seem to be failing with high frequency, the seal selection, installation process and adjoining component quality should be examined rather than just continuously replacing worn seals with new, identical seals. Different seal material or seal design may be needed if the existing operating conditions are resulting in very short seal lives. Seal selection is dependent on a review of application conditions such as shaft speed, shaft material, environmental conditions, temperature, pressure differential across the seal, contaminants, lubricant and other factors. Reduced seal life may be a result of any of these or a combination thereof.

Lip seals only work well when properly installed. If the seal is cocked in the seal bore, then poor performance will result. Damage to the seal lip during installation will obviously shorten seal life. Basic tips on seal installation include

making sure no burs or sharp edges exist in the seal bore, on the shaft, at the edges of keyways or on any surface the seal must pass over or into. Make sure there are no scratches or dents on the counterface surface where the seal lip will ride. Pre-lubricate the seal prior to installation with the same lubrication that will lubricate the seal in service. Use correct installation tools (see Figure 4) that will closely fit the seal and direct force at the outer edge of the seal body. Make sure the seal is faced in the correct direction and that the seal lip is not inverted after installation.

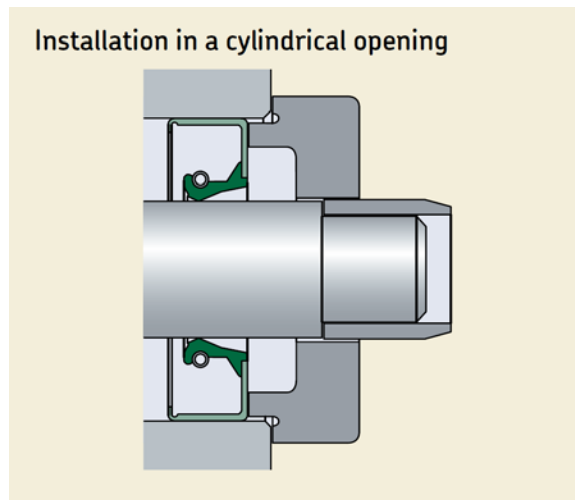

Figure 4. Proper installation of a seal including use of shaft sleeve and fitting tool

Shaft surface characteristics are also important. If the shaft is too rough or if there is a spiral lead to the surface, seal wear and leakage will happen quickly. Check the seal manufacturer's recommendation for surface finish, form and hardness requirements and verify the condition of the sealing surface. These characteristics vary by seal diameter and are fairly complex so they cannot be easily summarized. Shaft roughness recommendations, directionality and hardness are reasonably straightforward and are critical to performance so values are shown here (see Figure 5).

Recommended shaft surface roughness values						
	ISO		DIN		RMA	
	$\mu\text{m}$	$\mu\text{in.}$	$\mu\text{m}$	$\mu\text{in.}$	$\mu\text{m}$	$\mu\text{in.}$
$R_a$	0.2-0.5	8-20	0.2-0.8	8-32	0.2-0.43	8-17
$R_z$	1.2-3	48-120	1-5	40-200	1.65-2.9	65-115
$R_{pm}$	N/A	N/A	N/A	N/A	0.5-1.5	20-50

Figure 5. Seal counterface surface roughness values

Directionality is also very important. Lead on the surface can cause seal leakage. Plunge grinding of the counterface surface is suggested to reduce lead. When plunge grinding the surface, continue grinding until the wheel sparks out completely to minimize directionality. Shaft lead angle should be  $0 \pm 0.05^\circ$ .

Shaft hardness, as a general recommendation, should be 30 HRC or better. Depending on shaft material or coatings, the hardness may have to be greater.

Labyrinth seals may come in a variety of forms but certainly some of the more common and effective are cartridge type labyrinth seals (often referred to as isolator type seals) that include a rotating element that is mounted on the shaft and a stationary element in the housing (see Figure 6). The rotating element provides a flinger effect throwing contaminants off of the seal when it is rotating. The axial or face labyrinth created by the nesting of the rotating and stationary elements makes it extremely difficult for any type of contamination to pass through the seal. Lubricant is also prevented from exiting the housing keeping leakage to a minimum. Since there is no contact in this seal, no friction is created. These designs are typically more expensive than a lip type seal but there is no wear and no heat generation making them a long term investment rather than a wear part.

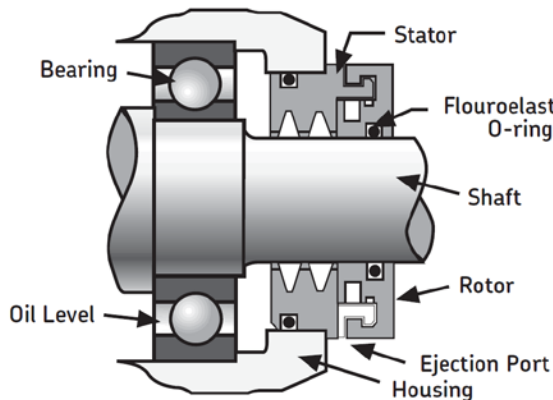

Figure 6. Isolator type labyrinth seal

Keeping contaminant out of the housing during operation is only part of the challenge. Any time the bearing housing is opened for any reason, care should be taken to prevent ingress of contaminants. Reasons why the housing may be opened would include changing the lubricant, replacing any components including bearings or simply inspecting the components.

Moisture is also a very serious contaminant. Water in oil will dramatically decrease the effectiveness of the lubricant and therefore reduce service life. Typical recommendations, depending on the source, are to maintain water at 100 or 200 ppm or less in the lubricating oil. This can be a challenge in some applications but should still be a target. While there is no widely recognized way of calculating the effect of moisture on bearing service life, testing has shown a dramatic drop in life as water content increases above that target. For example, two separate tests showed a drop in bearing life of 50% to 60% for an increase in water content from 100 ppm to 400 ppm. Considering that oil may not become cloudy from water content until roughly 1000 ppm, many bearings may be operating in lubrication conditions of high moisture content without any outward signs.

Due to the risk of life reduction, ideally, water content on new oil should be checked. Often new oil will already have reasonably high water content, depending on how it was stored, for example. Knowing the starting point is important to spot a trend. For oil bath applications, verifying moisture content should be part of

periodic oil testing. Once the moisture content is too high, the oil should be replaced. In circulating oil applications, dewatering can be part of the circulating oil system so that the water content of the oil can be maintained at a suitably low level.

One of the major routes for water to gain access to the bearing housing is ingestion of moist air into the housing when the pump is shut down and then cools. This moist air cools as the pump cools potentially resulting in condensation accumulating in the bearing housing. This is less of a problem for circulating oil systems because provisions are usually present within the circulating oil system to remove water while the oil is in the reservoir. Oil mist or air/oil systems also minimize this issue since the atmosphere in the housing is purged continuously during operation so cumulative condensation is not an issue. For oil bath or oil splash lubrication, where the risk is the greatest, water may be addressed in two different ways.

One solution to this moisture problem is to close the entire system with contact seals and use a closed system constant level oiler. Such a system incorporates an oiler to maintain oil level as well as an expansion tank and desiccant dryer to handle the changes in air volume and keep the system dry. Another simpler method is simply the incorporation of a breather which incorporates a desiccant cartridge. The desiccant will absorb moisture from the air being pulled into the housing. Usually such breathers also incorporate a filter to restrict particulate entry as well. Use of contact seals is advised in order to prevent another entry path for moist air. Use of the desiccant breather does not keep the system totally self contained but will reduce the moisture entering the system as well as oil vapor leaving the housing. Desiccant material must be replaced once it is saturated so this inspection and replacement of the desiccant and be factored into maintenance plans. The breathers should also be checked periodically to make sure they aren't painted over or otherwise blocked after other maintenance is performed.

### Lubrication types and lubricant selection

Lubrication is critical to successful bearing operation. In order to reduce stress, wear and friction, an oil film must be developed to

separate the rolling element surfaces from the raceway surfaces. Lubricant is also necessary to prevent wear and friction in sliding contacts like those between the rolling elements and the cage. Typical oil lubrication methods for pump bearings are oil bath, oil splash, oil mist, oil/air, and circulating oil. Grease is also used in many smaller pump applications.

For all oil lubricated applications, the critical factors are oil weight and additive selection. Oil weight (or viscosity grade) is critical because the oil must be viscous enough at operating temperature to separate the rolling surfaces but not so viscous as to create increased heat generation through viscous shear and churning. Calculations and charts are available to determine the minimum operating viscosity at operating temperature based on bearing size and operating speed. The calculation is heavily related to the operating speed of the bearing. The faster the rolling elements rotate, the lower the oil viscosity must be in order to separate the rolling surfaces. Below is a chart showing the required viscosity as a function of bearing size and speed (see Figure 7).

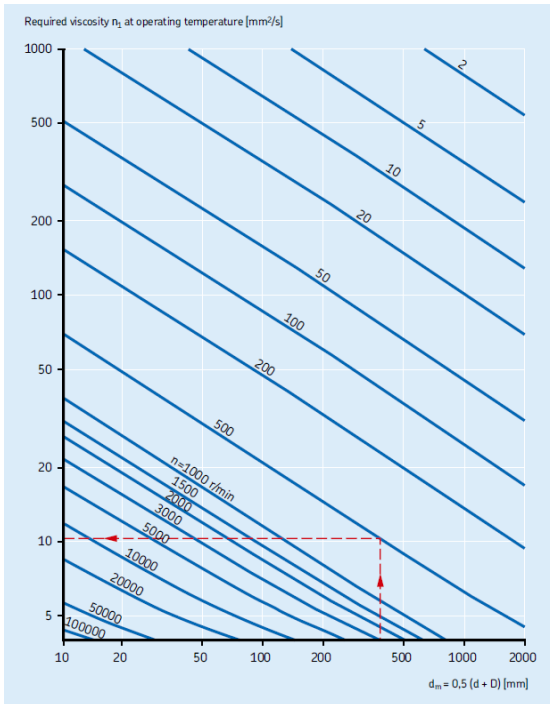

Figure 7. Required viscosity in centistokes ( $\text{mm}^2/\text{s}$ ) as a function of shaft speed and bearing size

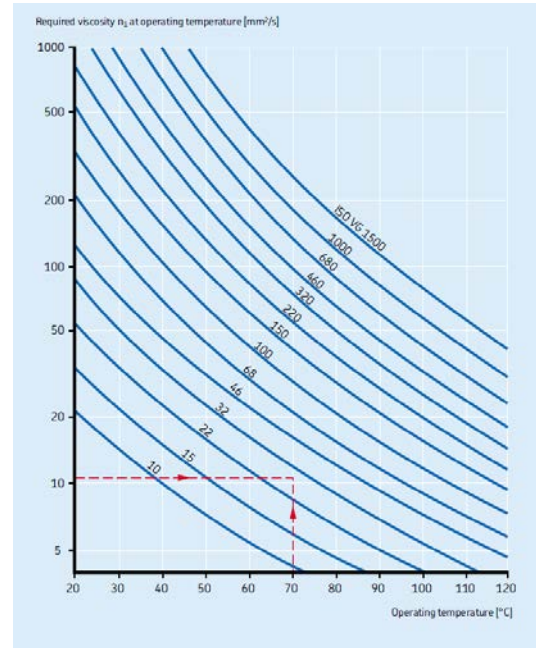

Figure 8. Oil viscosity at operating temperature for standard mineral oils

Once that is determined, an oil is selected that will provide 2 to 4 times that viscosity at the expected operating temperature. By examining temperature viscosity charts (see Figure 8), an oil weight can be chosen that will provide the desired viscosity at the estimated operating temperature.

This 2 to 4 time safety factor ensures that the contact between the asperities present on the surface of the contacting surfaces will be minimized or eliminated. If the actual viscosity will be less than the minimum requirement, boundary lubrication will occur which results in substantial metal to metal contact. Once the viscosity is over the minimum, mixed lubrication (meaning partial separation) will occur. As the viscosity is further increased, eventually full film lubrication is developed and the surfaces are totally separated (see Figure 9).

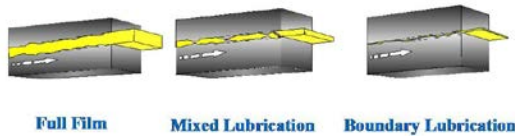

Figure 9. Three phases of lubrication film

Either mineral oil or synthetic oil can be used. Synthetic oils have the advantage that they maintain their viscosity better at higher temperature and are more resistant to oxidation. However, mixing oils of different types must be approached carefully since some synthetic oils are incompatible with other oil types (see Figure 14 for oil compatibility). Antioxidants and anticorrosion additives may be beneficial as may anti-foam additives. EP or anti-wear additives are typically not necessary since pump shaft speeds and operating temperatures are such that sufficient viscosity can usually be achieved to generate a lubricant film capable of separating the surfaces. EP additives can be chemically aggressive to bearing steel and may attack the surfaces, particularly at elevated temperatures. Their use is appropriate if sufficient viscosity cannot be provided.

Solid additives such as molybdenum disulfide (Moly or  $\text{MoS}_2$ ) or graphite should not be used in any oil or grease being used in a typical pump. These are appropriate for extremely slow speed applications or high temperature applications but not in typical pump applications. These dry lubricant particles, while beneficial at low speed, behave as contaminants at higher speeds.

Cleanliness and oil viscosity are very much related when examining bearing service life. A well developed lubricant film can tolerate more particles than can a very thin film. As a generality, for all applications, an ISO 4406 cleanliness level of 18/15/12 is recommended. Figure 10 shows that, for any given bearing size, varying the Kappa value (which is the ratio of lubricant viscosity at operating temperature to the minimum required viscosity) changes the contamination value,  $\eta_c$  (which indicates the level of contamination in an application). The  $\eta_c$  value varies from 0 (extremely contaminated) to 1.0 (extremely clean) and is an input to

calculating bearing fatigue life. The higher the  $\eta_c$ , the higher the fatigue life. This means that, relatively speaking, the effects on the bearing from a given contamination level will decrease with thicker lubricant film. Similarly, for a given Kappa value, reducing the contamination level (maintaining cleanliness to a better ISO 4406 level) will also improve life.

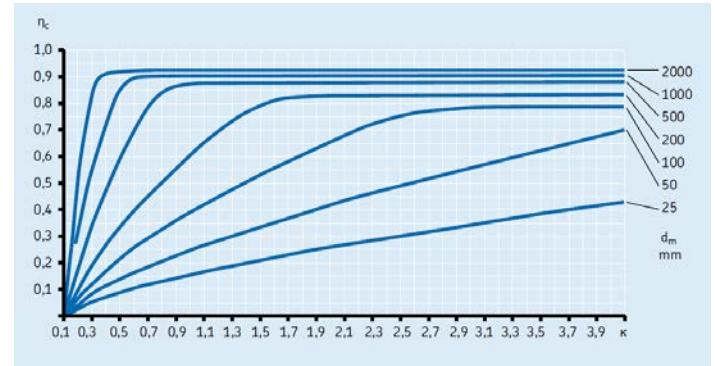

Figure 10. Contamination factor for circulating oil with solid contaminant level 18/15/12, ISO 4406

The 18/15/12 ISO 4406 contamination level is an appropriate limit for applications in general. For pumps, reducing that recommendation even further may be prudent. As the chart above shows, smaller bearings have a greater sensitivity to a given contamination level than larger bearings. Since the majority of ANSI and API pumps use relatively small bearings, if the cleanliness is maintained at 18/15/12, the  $\eta_c$  factor is likely to be in the 0.5 to 0.7 level. Such a level would be considered to be “normal contamination” for smaller bearings (those with a bore diameter less than 100 mm). Improving the contamination level to ISO 15/13/10 will increase that  $\eta_c$  value to a range of 0.6 to 0.8 or better. While this seems to be a small increase, it can change fatigue life substantially. Assuming a basic, unadjusted L10 life for a 7306 size bearing of 19,000 hours (with no adjustment for lubrication and contamination) and a Kappa value of 1.5, changing the  $\eta_c$  value from 0.5 to 0.8 increases the adjusted life of the bearing dramatically. The life adjustment factor (which takes into account the lubrication and contamination effects) will increase more than 4 times with that change in  $\eta_c$ . Simply stated, service life can increase 4 fold by improving and maintaining the oil cleanliness level.

## Lubrication Methods

Oil bath lubrication is very common (see Figure 11). The biggest challenge with oil bath lubrication is selecting and maintaining the oil bath height. The oil bath height should be left at the pump manufacturer's recommendation unless there is a strong reason to change. If the level is changed, make small changes and carefully monitor operating temperature and vibration levels to make sure the bearings are operating reliably. The typical recommendation is that the oil bath should be maintained at the center of the lowermost rolling element. This is checked when the shaft is not rotating. Varying this oil height can have dramatic effects on lubrication and heat generation due to churning of the oil. The higher the oil level, typically the greater the heat generation. Lowering the oil level may reduce heat generation but may starve the bearing if the level in operation is too low. The oil height should never be reduced to a level lower than 1 mm above the outer ring shoulder due to the risk of lubrication starvation.

While the rule of thumb is to maintain the oil level so it covers 50% of the lowermost ball, angular contact bearings may require slightly higher levels. An angular contact bearing, either single or double row will tend to pump oil out of the bearing towards the more open side. Usually this means the bearing is trying to reject the oil that is trying to flow in. In order to combat this, a slightly higher initial oil level may be necessary. Again, approach changes carefully and monitor temperatures.

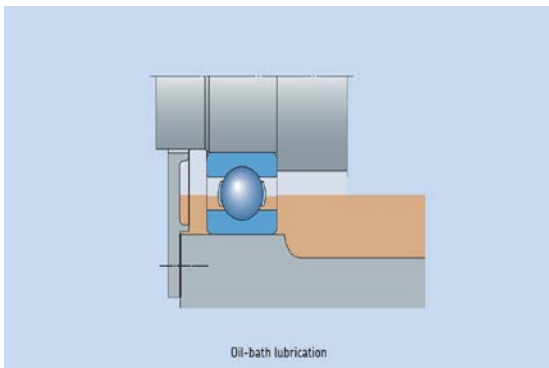

Figure 11. Typical oil bath arrangement and bath height for a deep groove ball bearing

Oil splash lubrication can be achieved with either oil rings or flingers. For oil ring lubrications (see Figure 12), a large diameter ring rolls against the shaft and through an oil sump and then slings the oil around the bearing housing cavity. This method typically has the static oil level below the bearing so churning of the oil by the bearing is largely eliminated. Oil will be thrown into the bearing and will then pass through. A means of oil draining back into the sump from the outboard side of the bearing is necessary to make sure a static level does not develop outboard of the bearing. Oil sump height is important here as well because if the ring does not dip into the oil enough, the oil ring will become unstable and insufficient oil will be distributed inside the housing. Too high a level may flood the bearings and increase heat generation. Oil ring stability is sensitive to shaft/ring geometry, oil viscosity and the mass of the oil ring.

Another method very similar to oil ring is the use of oil flingers. Instead of the oil ring hanging from the shaft, a disc is attached to the shaft. This disc (or flinger) dips into an oil bath which is below the bearings. As the shaft and flinger rotate, the oil adhered to the flinger is flung off and lubricates the bearings. The surface speed of the flinger is higher than that of the oil ring so this flinging affect can be more pronounced. However, if the flinger speed reaches a critical value, oil delivery drops to zero as the windage of the flinger prevents contact between the flinger and the oil. Similar to oil ring lubrication, the oil bath depth and how deeply the flinger sits in the bath are critical to distributing sufficient oil.

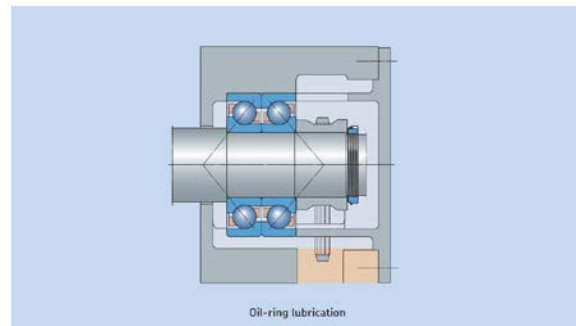

Figure 12. Typical oil ring system with the oil sump well below the bearing.



For both oil bath and oil splash lubrication, the oil must be changed periodically. The frequency is dependent on the oil type and operating temperature. As a generality, typical mineral oil lubricating bearings operating at 212 F (100 C) should be replaced approximately every three months due to oil oxidation. Lower operating temperatures will allow longer re-lubrication replacement cycles. Every six months should probably be an upper limit.

Ideally, oil should be changed based on oil sampling analysis rather than strictly time in service. Doing so can avoid unnecessary oil changes as well as ensure degraded oil is replaced in a timely fashion. The oil should be changed when oil samples show signs of viscosity change, oxidation, high particulate contaminant or high water content.

Oxidation is generally determined by TAN (total acid number) which expresses the amount of potassium hydroxide (abbreviated KOH, which is a base) needed to neutralize the acidity in one gram of oil. Typically, the units for the TAN number are mg KOH/mg oil. When that value increases, the oil is becoming more acidic. One of the causes of increased acidity is breakdown of the oil. New oil should have a TAN close to 0.0 but that value increases as oxidation byproducts increase. When the TAN is near 1.0, replacing the oil is advisable. For non-critical pumps, it may be allowed to go higher but at the risk of bearing damage. This value is not absolute since other causes, including contamination and additives, may also increase TAN.

Some oils, due to the presence of additives, will have TAN values above 0.0 when new. In this case, when first put in service, typically the TAN value will drop initially as the additives are depleted and then eventually rise when oxidation occurs. In this case, when the TAN value surpasses the original value, replacing the oil is advised.

Circulating oil has the benefits of being able to remove heat as well as lubricate the bearings. Also, as mentioned above, the oil can be filtered and dewatered while it is being cycled through the reservoir prior to being introduced into the housing. The biggest challenges for circulating oil are to make sure the flow rate is correct. Too

little oil flow may yield a low temperature but may starve portions of the bearings. Too high a flow will increase bearing heat generation through churning and may lead to leakage. A calculation that can be used to develop a starting point for oil flow rate per bearing is:

$$Q = 3 \times 10^{-5} D B$$

Q is the oil flow in liters per minute, D = bearing OD in mm and B = bearing width in mm. This flow can be adjusted up or down slightly to optimize performance.

Additionally, oil must be able to drain from the housing. In addition to drains in the main portion of the housing, drain backs must be present from the outboard sides of the bearing to the sump or additional drains must exist in those outboard areas. These drains or channels allow oil that has passed through the bearings to drain. After a bearing failure, make sure that any channels, drains or drain backs are cleaned out and open so oil may return to the reservoir and no contamination remains to damage new bearings.

Oil mist and oil/air are two other lubrication methods that are related but differ in major ways. Oil mist has the oil in very small particles suspended in the air creating a mist that is blown into the housing and then allowed to pass through the bearing and then vented to the atmosphere. There must be an air path from where the mist is introduced through the bearings and out of the housing. If the mist is not flowing through the bearings, starvation will occur. Mist escapes from the housing and is then vented to the atmosphere, which can be an environmental and safety problem.

Oil/air involves pressurized air being fed directly to each bearing in the housing. Periodically, oil droplets are released into the air stream and this oil migrates down the air line to the desired item to be lubricated (see Figure 14). Similar to mist, there must be an air path out of the housing but in this case, since the oil is not atomized, the droplet comes into the bearing as a liquid and only air escapes the housing. Both mist and oil/air are considered total loss systems since the oil is not automatically recycled or fed back into the lubrication system. For oil/air, the oil does collect in the housing and should be drained into a catch bottle which can be emptied periodically.

This oil can be recycled but should not be returned to the lubrication system for re-use since it may be contaminated.

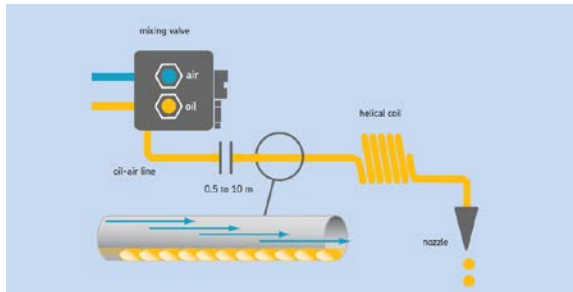

Figure 13. Oil/Air lubrication introduces very small amounts of oil into the bearings

Very small amounts of oil are used for oil/air systems. This has the advantage of reducing viscous losses and resultant heat generation. The recommendation for the amount of oil used varies depending on the specifics of the application and the system supplier but the following formula provides a general guideline as well as an understanding of the order of magnitude of oil used.

$$Q = 2 \times 10^{-2} d B$$

Where  $Q$  = oil amount ( $\text{mm}^3/\text{hour}$ ),  $d$  = bearing bore (mm),  $B$  = bearing width (mm)

One of the biggest benefits of either system is that the pressurization of the housing and resultant mist or air flow out of the housing serves to prevent ingress of contamination. Therefore, cleanliness inside the bearing cavity is typically excellent. The biggest risk, particularly when retrofitting existing equipment, is ensuring that the flow of mist will go through the bearings. Also, contact seals which also have to be lubricated, may not function with mist or oil/air since mist or air will not pass under the seal lip thereby starving the seal and decreasing life.

Grease lubrication is not as common in pumps but is used in some instances. Grease has the advantages that it is easy to apply, assists in the protection of the bearing from contamination and minimizes leakage. Disadvantages include poor heat dissipation, retention of contaminants and poor ageing characteristics. Some of the biggest maintenance risks with grease are the grease

re-lubrication procedure and potential mixing of greases. Grease has to be replenished periodically as the base oil breaks down. Fresh grease is typically pumped into a cavity next to the bearing and then forced through the bearing to purge old grease from inside the bearing and replace it with new fresh grease. The frequency of this replenishment is very important. Calculations are available from most bearing manufacturers to predict this frequency. The more thorough calculations adjust the basic calculation for operating conditions such as temperature, load level, contamination and vibration levels. Depending on these additional factors, the re-lubrication frequency may have to be adjusted substantially. Too frequent a re-lubrication period wastes time and grease while too infrequent re-lubrication may starve the bearings.

If the grease being used is going to be changed to a different grease, there is a risk of interaction between these two lubricants. Not all thickener types are compatible with each other so this should be checked before re-greasing with a different grease (see Figure 14 for thickener compatibility). Ideally, the bearing housing should be opened and all old grease removed before the new grease is introduced. This is often not practical so verifying the compatibility of the grease thickeners is the next best thing. Note that additives may conflict with each other as well. Lastly, if grease with an unusual base oil is going to be used, base oil compatibility should be verified before introducing the new grease into the bearing housing. Grease manufacturers may be able to comment on the compatibility of their greases with other grease types and contacting them is easier than testing grease compatibility.

Thickener compatibility chart											
	Lithium	Calcium	Sodium	Lithium complex	Calcium complex	Sodium complex	Barium complex	Aluminum complex	Clay (Bentonite)	Common polyurea*	Calcium sulphinate complex
Lithium	+	●	-	+	-	●	●	-	●	●	+
Calcium	●	+	●	+	-	●	●	-	●	●	+
Sodium	-	●	+	●	●	+	+	-	●	●	-
Lithium complex	+	+	●	+	+	●	●	+	-	-	+
Calcium complex	-	-	●	+	+	●	-	●	●	+	+
Sodium complex	●	●	+	●	●	+	+	-	-	●	●
Barium complex	●	●	+	●	-	+	+	+	●	●	●
Aluminum complex	-	-	-	+	●	-	+	+	-	●	-
Clay (Bentonite)	●	●	●	-	●	-	●	-	+	●	-
Common polyurea*	●	●	●	-	+	●	●	●	●	+	+
Calcium sulphinate complex	+	+	-	+	+	●	●	-	-	+	+

+ Compatible  
 ● Test required  
 - Incompatible

Base oil compatibility chart							
	Mineral/PAO	Ester	Polyglycol	Silicone Methyl	Silicone Phenyl	Polyphenylether	PFPE
Mineral/PAO	+	+	-	-	+	●	-
Ester	+	+	+	-	+	●	-
Polyglycol	-	+	+	-	-	-	-
Silicone methyl	-	-	-	+	+	-	-
Silicone phenyl	+	+	-	+	+	+	-
Polyphenylether	●	●	-	-	+	+	-
PFPE	-	-	-	-	-	-	+

+ Compatible  
 ● Test required  
 - Incompatible

Figure 14. Grease thickener and base oil compatibility should be checked when mixing lubricants

### Mounting and dismounting techniques and tools

Installing new bearings is a critical step in maximizing bearing reliability. If the bearings are incorrectly mounted or damaged during installation, life will be shortened. Therefore, use of sound proven techniques is critical. For small bearings, defined as bearings with outer diameters of 4 inches or less, the bearings can be cold mounted. Above that size, heating the bearings is recommended. When cold mounting, force must be directed against the ring with the interference. Typically this means pressing against the inner ring because the bearing usually is mounted with an interference fit on the shaft. Force may be applied using an arbor press or an impact sleeve and hammer (see Figure 15). No blows should be directed to the bearing itself. Rather, a sleeve should contact the bearing and blows be directed against the end of that sleeve. Use of a dead blow hammer is also suggested.

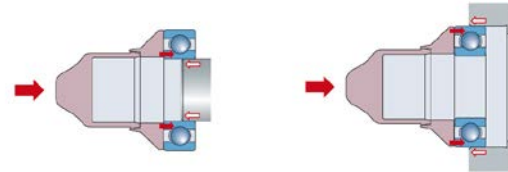

Figure 15. A sleeve should be used when pressing a bearing onto a shaft or into a housing

For hot mounting, care must be taken to not overheat a bearing. Bearings are limited in maximum temperature by the metallurgy of the rings as well as by use of any non-metallic components such as nylon cages or rubber seals. A good general rule of thumb is to heat bearings to a temperature 150 F greater than shaft temperature. This is sufficiently warm to allow the bearing to slide over the shaft while not hot enough to damage any components. In any case, do not heat open bearings above 250 F. For bearings that have closures and are greased for life, 210 F is recommended as a maximum temperature so the 150 F difference over shaft temperature may have to be reduced somewhat for greased for life bearings.

While ovens, hot plates and oil baths work, the simplest method to heat a bearing is with an induction heater (see Figure 16). The process is quick, accurate, repeatable and safe. Make sure operating instructions and warnings are followed because induction heaters create a strong magnetic field which can be a hazard. When heating bearings, it is critical to use an induction heater that has a demagnetization cycle built in. During the heating process, the bearing is magnetized by the induced current. If that magnetic field is not eliminated, the bearing will attract all ferrous debris in the oil. Usually the heater's demagnetization cycle operates just before the heater shuts off so the full heating cycle must be completed before the bearing is removed from the heater and installed.

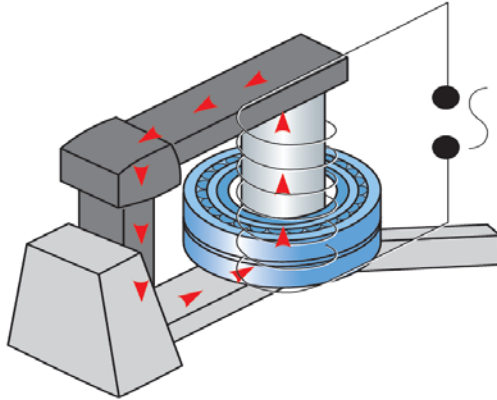

Figure 16. Induction heaters rapidly heat the bearing by creating current in the bearing rings

When installing heated bearings, the bearings should be pressed against the shaft shoulder and then the locknut installed and clamped against the bearing. As the bearing cools, it will shrink both radially (creating the interference fit on the shaft) and axially (potentially causing it to pull away from the shoulder). As the bearing cools, the locknut should be further tightened using an impact spanner wrench or, for small bearings, a regular spanner wrench, to keep the bearings tightened against the shoulder. Once the bearing is cooled, the locknut should be removed, the lockwasher placed against the bearing and the locknut reinstalled against the lockwasher. The locknut should be tightened until it is in intimate contact with the washer and the bearing is tight against the shoulder and then the appropriate lockwasher tab bent down into the locknut slot.

Making sure the bearings are drawn hard against the shoulder is especially important for paired angular contact ball bearings. If the rings are not clamped tightly between the locknut and the shoulder, too much axial clearance may exist. When tightening the locknut with an impact spanner wrench, blows on the spanner will give a dull sound until the rings are in intimate contact. Once all of the components are tightly against each other, blows against the spanner will produce a ringing tone. This tone change indicates things are sufficiently tight. While torque specifications are published for locknuts, they can be difficult to apply because specific

thread tolerances, roughness and lubrication (or lack thereof), will change locknut torque substantially. There is an upper bound for what axial clamping force should be applied to a bearing. This maximum axial clamping force is equal to  $\frac{1}{4}$  of the static capacity ( $C_0$ ) for the bearing. Any greater clamp force may deform the rings changing internal load distribution and contact pressures thereby reducing life.

The correct tools should be used for all of these activities. Attempting to use a drift or piece of bar stock may succeed in tightening the locknut but there is a risk of damaging the nut and/or the bearing. Additionally, small pieces may break off of improvised tools and these pieces could enter the bearing and cause damage during operation. Lastly, a torch should never be used to heat the bearing prior to installation. Such direct heat will permanently damage the heat treatment of the bearing and shorten life.

After mounting bearings, check to make sure that everything appears to have been mounted correctly. If a bearing is cocked relative to the shoulder, axial vibration may result. If the bearings do not turn freely, friction and wear may result. If the locknut is not firmly mounted against the bearings and the lockwasher tab secured, the bearings may shift axially potentially causing interference between the impeller and the casing. Check the installation job to make sure everything appears to have been done correctly. Bearings should turn smoothly after installation. Even preloaded bearings will turn smoothly though the preload will require more torque to be applied to get the rings to turn.

When bearings have to be removed, appropriate tools should be used here as well. While salvaging the bearings may not be necessary, use of incorrect tools such as sledge hammers, torches etc may damage other expensive components such as the shaft. Bearings pullers are the best way to remove bearings and do so in a way to eliminate risk to other pump components.

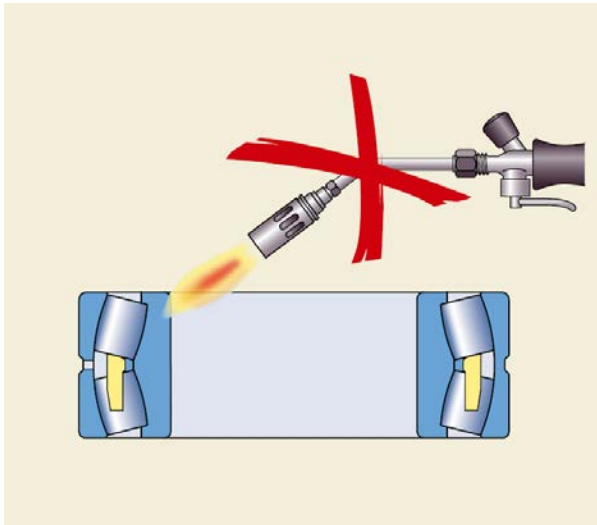

Figure 17. Torches should never to be used to heat bearings since ring damage will occur

#### **Correct component selection**

After removing existing failed bearings, take care to use correct replacement parts. Replacing the bearings with an exact match is the easiest way to make sure the right bearing is used. Certainly bearings from one manufacturer can be interchanged to those from another but when doing so details are very important. Exterior dimensions of bore, OD and width must match. Tolerance class should be equal or better for the replacement. Features such as contact angle, cage type and clearance/preload must be compared to make sure the bearing will function correctly in the pump. Contact angles should not be changed unless there is a reason to do so. The contact angle determines how well the bearing supports axial loading. As an example, typical thrust bearings in API pumps have 40 degree contact angles. Use of a replacement bearing with a 30 degree contact angle will increase internal stresses in the bearing when subjected to an axial load. Clearance or preload class is very important as well because that will determine how much clearance or preload is present after the bearings are mounted.

Other replacement components like seals, wear rings and impellers must also be true to the original designs or changes to the operational characteristics of the pump may result. Wear ring or impeller design changes may very likely change the axial loads applied to the thrust bearings. Such changes may shorten service life

so any component changes have to be approached carefully.

In general, reusing bearings is not recommended for several reasons. Firstly, bearings are critical to the reliability of the pump. There is a great deal of time and effort dedicated to rebuilding a pump and all of that is wasted if used bearings are installed and they fail quicker than expected. While bearings are costly, that cost pales in comparison to the cost of downtime for most operations. If a repair to the pump shaft requires bearings to be removed, installing new bearings instead of re-installing the original ones is cheap insurance.

Another reason to avoid reusing bearings is that removal of the bearings from the shaft typically damages the internal surfaces. Unless bearings are pulled from the shaft with force directed against the inner rings, damage to the raceways is likely. Since accessing the inboard side face of a bearing is very difficult, removal usually involves pulling on the outer ring. Brinell damage is very likely. A third reason for not re-using bearing is that bearing fatigue failures originate with subsurface cracks that then propagate to the surface creating what is known as a spall. Examination of a used bearing may not show any outward signs of impending failure but such cracks could already exist and be working their way to the surface. Short of extensive laboratory testing, there is no easy way to identify how much longer a bearing will function.

Paired angular contact ball bearings are unique in that their side faces are modified for flushness. When the bearings are clamped against each other in a face to face or back to back arrangement, the desired clearance or preload is created. When the bearings are mounted on the shaft with an interference fit, additional clearance is removed from the bearing set. Any temperature difference between the inner ring and the outer ring also changes this clearance. Since the inner ring is typically warmer than the outer ring, a temperature difference usually serves to further decrease the clearance (or increase the preload). All of these factors interact to create the operational clearance or preload so changes to bearing bore tolerance, shaft tolerance, un-mounted clearance or operational temperature

can change the mounted clearance (see Figure 18).

Bearing life, heat generation and control of the non-thrust carrying ball set are very sensitive to mounted clearance. Changing from one clearance/preload class to another or changing from one manufacturer to another must be done very carefully. When the bearings function preloaded, any additional preload creates ever increasing stresses and typically higher temperatures as well as ring temperature differences. The result can be a thermal runaway where the increased friction in the bearing from the higher stress increases the temperature resulting in even greater stress. This cycle causes a rapid high temperature failure. Before changing components, check the entire system to understand the end results of a bearing change.

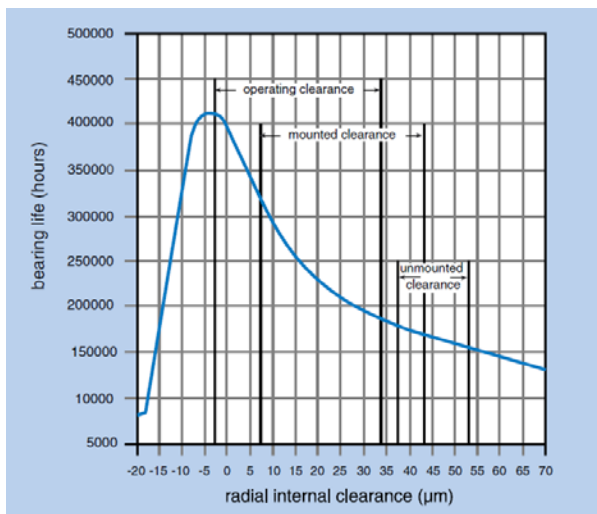

Figure 18. Operating clearance is a function of shaft fit and thermal effects

### Control of rolling elements in the inactive bearing

The goal of clearance or preload selection is to have the bearing functioning with an operating clearance close to zero. A light preload actually increases fatigue life because all of the rolling elements are carrying load. As a result, the load on the most heavily loaded rolling element decreases slightly. However, if more preload is applied, every bit of additional preload directly translates to stress and resultant decrease in fatigue life. That decline is quite pronounced so

operating with excessive preload is a definite risk to life. Since heat generation also increases with additional preload, there are thermal risks to the bearing and the lubricant associated with high preload levels.

There are risks at the other extreme as well. Excessive clearance can result in greater load on the most heavily loaded rolling element. The greatest risk is actually to the least loaded, or inactive, bearing. The main thrust carrying bearing (the active bearing) in a set of angular contact ball bearings typically has all of its rolling elements loaded. The opposed bearing (the inactive bearing) may have few of its rolling elements actually carrying load. As clearance increases, the number of balls carrying load decreases. These unloaded balls tend to slow down when out of the load zone and then speed up when reentering the load zone. During that reentry, if the balls cannot accelerate quickly enough, they may skid or smear the raceway. This friction created by that sliding will increase the temperature and oxidize the lubricant as well as damage the rolling surfaces. Surface fatigue is the most likely result of skidding damage.

In order to control these unloaded rolling elements, the clearance in the bearing can be reduced. As stated earlier, the usual goal is for the operating clearance to be near zero. The purpose of the low clearance (or slight preload) is to have very few balls unloaded and those that are unloaded will have very little time to decelerate. However, depending on the application, problems with ball skidding can still happen. This may happen because the temperature differential between the inner and outer rings is not as great as expected or because the axial deflection from high axial loading increases the clearance in the inactive bearing. When these problems happen, there are a couple of approaches that can be tried.

The most common solution is to use a set of bearings designed to create a preload when mounted. More heavily preloaded bearings do come with risks, as noted above, but this solution often overcomes the problem. Particularly if the extra heat generated can be removed by circulating oil, oil mist or oil/air lubrication, this can be a very simple and effective solution.

Another option is to use dissimilar bearings. Both the active and inactive bearings typically have 40 degree contact angles. However, instead of using the same bearing in both positions, a bearing with a lower contact angle can be substituted as the inactive bearing (see Figure 19). The shallower contact angle (15 degrees is the most common) creates less of a tendency of the balls to skid. This solution is quite effective and does not typically increase heat generation. Use of this solution is dependent on knowing with certainty which bearing is the active bearing otherwise the less capable bearing with the shallower contact angle will be forced to support the axial loading. Problems can also happen if the pump often sees substantial, prolonged reverse axial loading since, again, that load is applied to a bearing that is not as capable at supporting thrust loading.

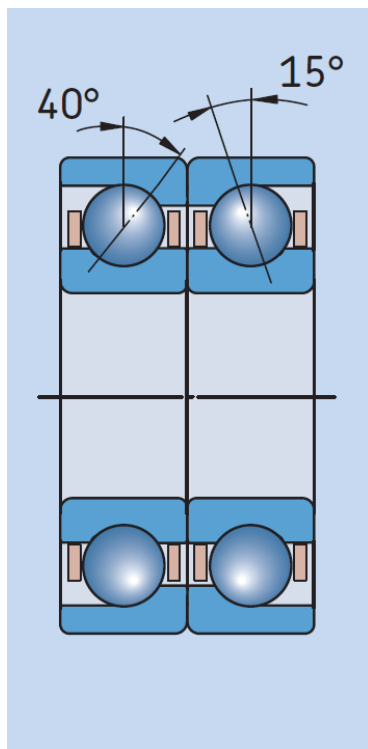

Figure 19. Angular contact bearing pair with dissimilar contact angles

### Mating components

Tolerances on mating components are also important. Bearing seat diameters on both the shaft and in the housing must be correct. The diameter tolerances are important but so are form

tolerances. An out of round housing or shaft will result in an oval bearing. Bearing rings are relatively thin so they conform to the shaft or housing they are mounted in or on. As a general rule, the roundness tolerance should be half of the diameter tolerance. Too much out of round may result in an increase in contact pressures within the bearing thereby reducing fatigue life. Vibration can also result, particularly for out of round shafting. Shoulder squareness can also cause vibration problems and should be checked before mounting new bearings.

### Housing support and alignment

Just as the bearing will conform to the housing or shaft seat, the entire bearing housing can distort depending on the surface to which it is mounted. The foundation must be substantial enough and the grouting done correctly such that the pump bearing housing is firmly supported without any distortion of the pump components. Potential problems can arise including soft foot where one or more mounting locations are not adequately supported. Housing distortion, increased component stress and increased vibration can all result from inadequate foundation support. Therefore, the quality of the foundation installation should be checked. Alignment of the pump should be checked and set before grouting and then again after grouting to make sure alignment was not affected by the grouting process. Checking alignment again after connecting piping (in case pipe stress is affecting alignment) and after initial operation is also advised to make sure no changes have occurred in each stage of installation.

Misalignment is one of the quickest ways to reduce bearing service life. Particularly for angular contact ball bearings, any misalignment will reduce service life. For bearings mounted in pairs, particularly those with very small clearances or bearings with preload, misalignment can only be accommodated by increased rolling element loads and deflections, which also create increased cage stresses and reduced service life. Any misalignment will also create an increase in noise and vibration. Figure 20 shows the decrease in life as a function of misalignment. Life curves are shown for bearing pairs mounted with preload (GA) or clearance (CB) in both face to face and back to back

arrangements. Back to back is the most common arrangement. Face to face is more tolerance of misalignment but such an arrangement requires the outer rings to be clamped axially and is more susceptible to thermal run-ways.

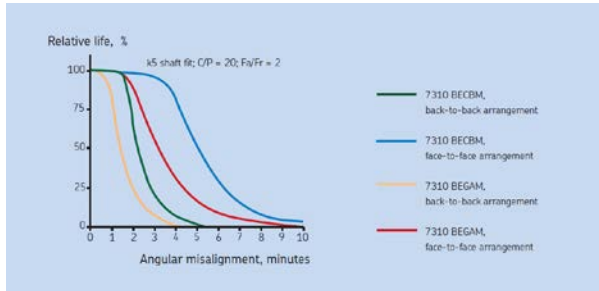

Figure 20. Misalignment can reduce angular contact bearing life dramatically

### Effects of varying operating conditions

From an operational standpoint, numerous conditions can affect bearing life. Certainly issues like cavitation and pipe stress can be detrimental to bearing operation. Operating off of the BEP (Best Efficiency Point) can certainly change bearing life as well. Anything that changes bearing loading will change life. Since bearing fatigue life is a cubic relationship to load, a 10% increase in applied load reduces fatigue life by 25%. Heavier loads also increase heat generation thereby reducing lubricant viscosity. This reduces life even further. While there may be times it is necessary to operate a pump well off of BEP, realize that long term pump bearing life and reliability may be seriously jeopardized by doing so.

Inactivity can be another risk for a pump and its bearings. Either when the pump is being shipped or when it is installed but inactive, exposure to vibration can be a serious threat. That vibration when the bearings are not rotating can cause the balls to move back and forth relative to the raceways causing false brinelling. False brinelling looks like a dent in the raceway but actually is a wear phenomenon. Since the rolling element is harder than the raceway, its movement gradually wears the raceway. In extreme cases, a trough is actually worn in the raceway.

Subsequent operation over-rolls these wear areas or troughs creating noise and vibration. Premature fatigue surrounding these troughs will

also occur. This potential problem is more likely for oil splash lubricated bearings or bearings using circulating oil, mist or oil/air since there is very little to no lubrication in the bearing when the bearings are static. For pumps in transit, this risk can be minimized by strapping or otherwise restraining the impeller shaft so the bearings are loaded and prevented from moving. When pumps are installed but not operating, such as a back-up pump, the pump impeller shaft should be rotated periodically to make sure fresh lubricant is distributed and to move the rolling elements to a new location. Redistributing the lubricant also helps to prevent static corrosion from occurring.

### Condition Monitoring

Following these suggestions and best practices will improve bearing service life. However, even very well maintained bearings may still fail in service. Being able to detect problems at an early time and then predict when the bearings must be replaced can be very helpful in minimizing down time, lost production and other consequences. Condition monitoring is the best tool for detecting potential failures and estimating remaining service.

Typically condition monitoring involves taking vibration readings from the bearings. While handheld probes can be and are used, the best and most consistent readings are taken with permanently installed sensors. Hand held readings should be taken from defined positions on the pump. Ideally those locations should be spot faced to get good contact. Permanently installed sensors can be fed to a junction box where readings can be taken by a data collection device or can be hard wired into a central condition monitoring system. Whether hand held or permanently installed, avoid taking readings on painted surfaces, in areas where the bearing is not supporting load, near housing splits and in areas with structural gaps. For handheld readings, pay close attention to the sensor position, angle relative to the surface and applied pressure. When possible, readings should be taken in three axes (axial, horizontal and vertical).

Regardless of how the readings are taken, the signals that are gathered form a picture of how the bearings are functioning. Rolling element bearings create or excite certain vibration



frequencies due to the internal geometry of the bearing. Frequencies associated with ball pass on the inner ring, ball pass on the outer ring, ball spin and cage rotations are the typical vibration spikes seen from a bearing. When a problem occurs in the bearing, one or several of these frequencies and their harmonics will see an increase in amplitude. The challenge is to spot that increase and interpret its meaning. Defects such as fatigue spalls, false brinells, true brinells, debris dents, localized corrosion, looseness and inadequate support can typically be spotted using condition monitoring. Depending on the system signal processing, lubrication problems may also be possible to detect.

The most common vibration characteristic measured is velocity. Typically, however, an accelerometer is used to take the readings and the velocity calculated from the acceleration reading. Velocity readings can be used to diagnose most problems however some require acceleration readings or acceleration readings together with additional signal processing. The most valuable approach is to look at the trend over time. Looking at one particular vibration spectrum will often not tell much of a story unless one specific frequency is showing a very high amplitude. Instead, a waterfall display or other trending tool should be used to look at the trend over time. When a certain frequency is shown to be increasing consistently over time, a problem has likely been identified. Depending on the rate of change and the criticality of the pump, an estimate of urgency of repair can be developed based on experience.

Bearing temperature is often used as an indicator of bearing condition. Temperature is a useful piece of information but may not be as reliable an indicator of failure. Often, problems start to develop and temperature may increase slightly but only when the failure mode has progressed to a serious level does temperature increase dramatically. Typically that temperature increase can be very rapid necessitating a shutdown. So, temperature data may not provide the longer term trend necessary to be able to head off a problem before it becomes critical.

Detecting a problem is often relatively simple using condition monitoring. Determining the root cause of the higher vibration signal is often much more challenging. Setting alarm levels,

determining how serious the issue is, filtering out basic rotational and structural vibrations to see bearing or gear problems are all necessary skills for the vibration analyst that take time and experience to develop. Condition monitoring can be a very valuable tool in maintaining machinery but only if those using it have the background and experience to use it to its full potential.

## Conclusion

Maintaining bearings and achieving long service lives is not a simple task. Many things contribute to shortening their lives. Therefore, many different aspects have to be optimized to improve service life. There are definite interrelationships between many of these factors as well. For example, excellent lubrication can minimize damage from a certain contamination level while poorer lubrication will allow damage to the bearings with that same level of contamination. This means that all of these factors should be looked at rather than just targeting one or two. Overall, good solid installation practices, awareness of cleanliness and proper lubrication requirements will extend bearing life beyond what may be considered the norm.

## References

- Ioannides, E., Bergling G., Gabelli, A., 1999, An Analytical Formulation for the Life of Rolling Bearings, Acta Polytechnica Scandinavica publication Me 137.
- SKF, 1995, *Bearings in Centrifugal Pumps Application Handbook*, SKF USA Inc, Lansdale PA.
- SKF, 2005, *General Catalog*, SKF AB, Gothenburg, Sweden.
- SKF, 2011. *SKF Bearing Maintenance Handbook*, SKF AB, Gothenburg, Sweden.
- Thomas, R., 2004, Maintaining Proper Quantity/Quality Lubrication in Horizontal Process Pumps. Lubrication Excellence 2004 Conference and Exhibition.
- Thomas, R., 2006, Best Practices for Lubricating API Centrifugal Pump Bearing Housings. Lubrication Excellence 2006 Conference and Exhibition.