

Applications of Microseismic Monitoring in China's Underground Coal Mines

Zara Hosseini

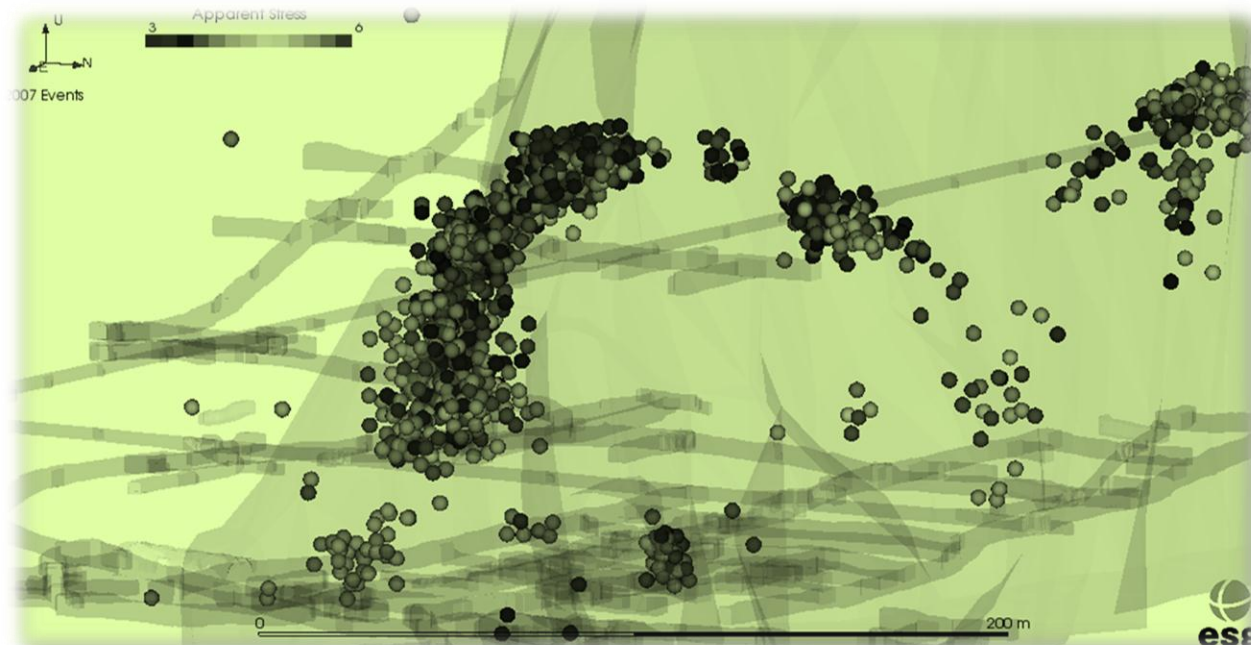

- Microseismicity
- Seismic Systems
 - Intrinsically Safe and Explosion Proof Seismic System
- Case studies:
 - Gas Drainage Optimization
 - Fault Identification
- Conclusion



Seismic Event

- Occurrences in which energy is released in the rockmass creating a series of seismic waves propagating throughout the rockmass
- Can cause a Fall of Ground or CoalBurst

Factors creating Seismicity:

- Mining at Depth
- High stress zones
- Major geological structures
- Mining practices and strategies
- Mining activities i.e. drilling and blasting

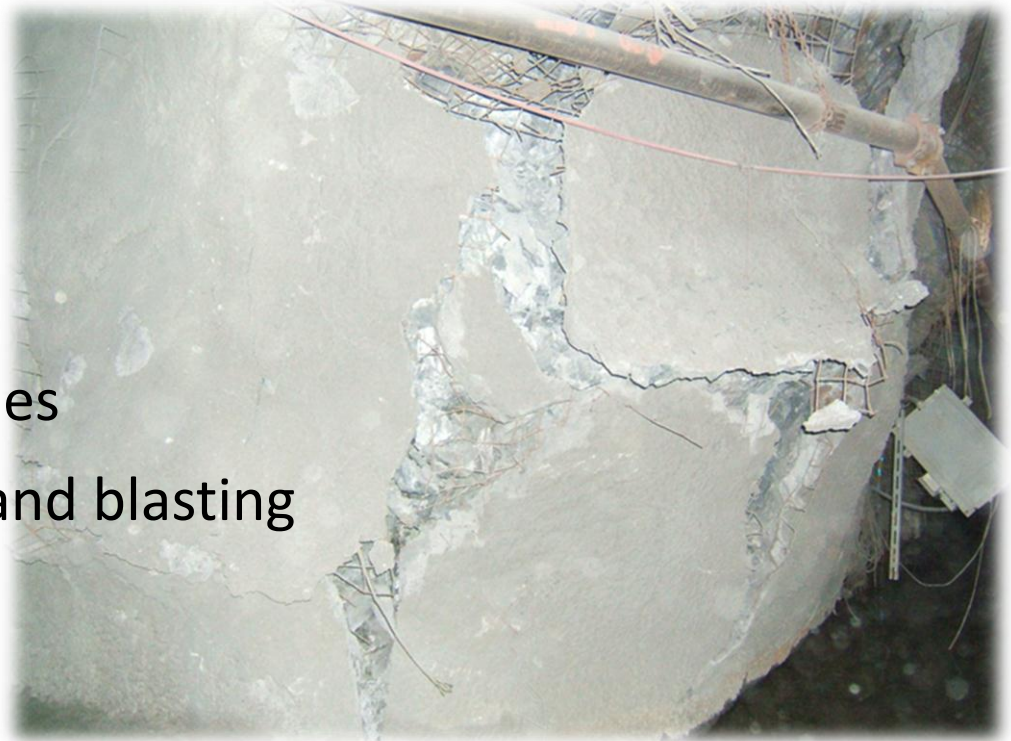

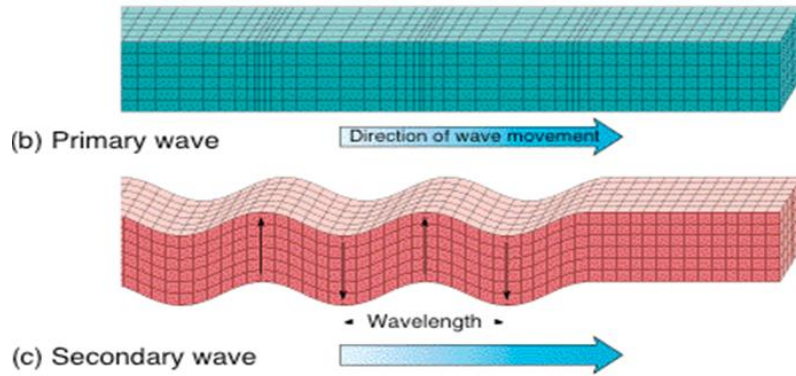

Two types are mainly used in seismic processing:

- Primary wave (P-wave)
- Secondary wave (S-wave)
- P-wave velocity is often 1.73 times faster than S-wave velocity

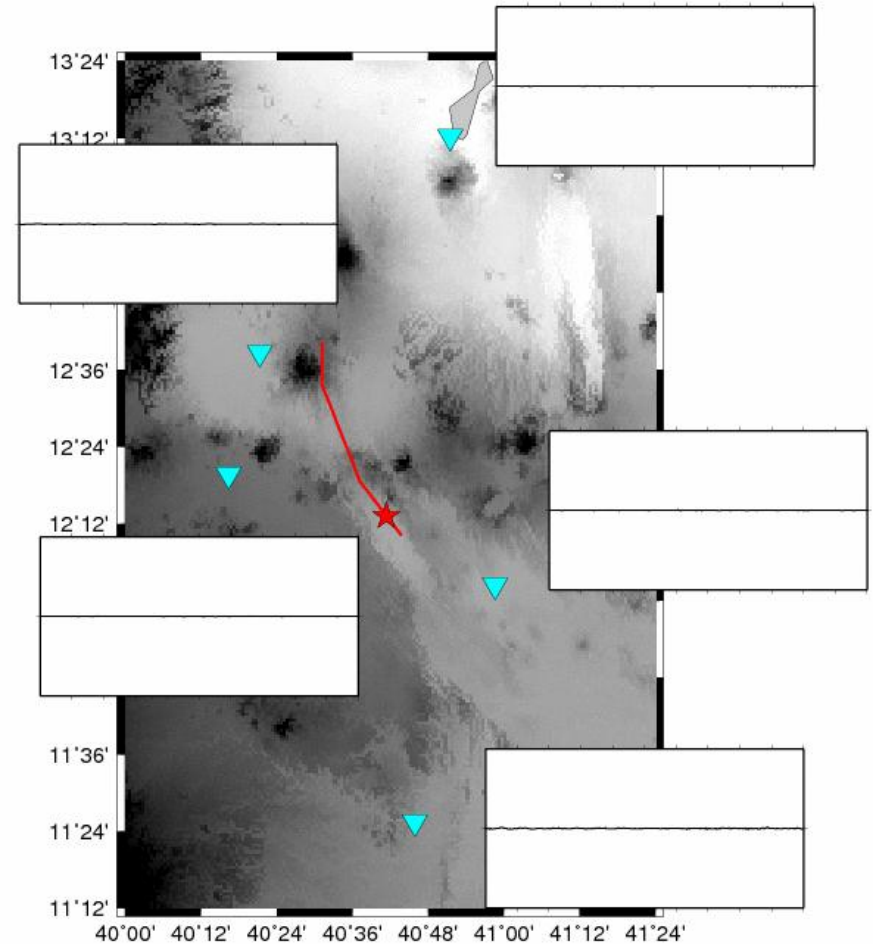

- Surface systems (for monitoring Seismic or larger magnitude events)
- Underground systems (For monitoring Microseismicity or smaller events)
- Combined architecture



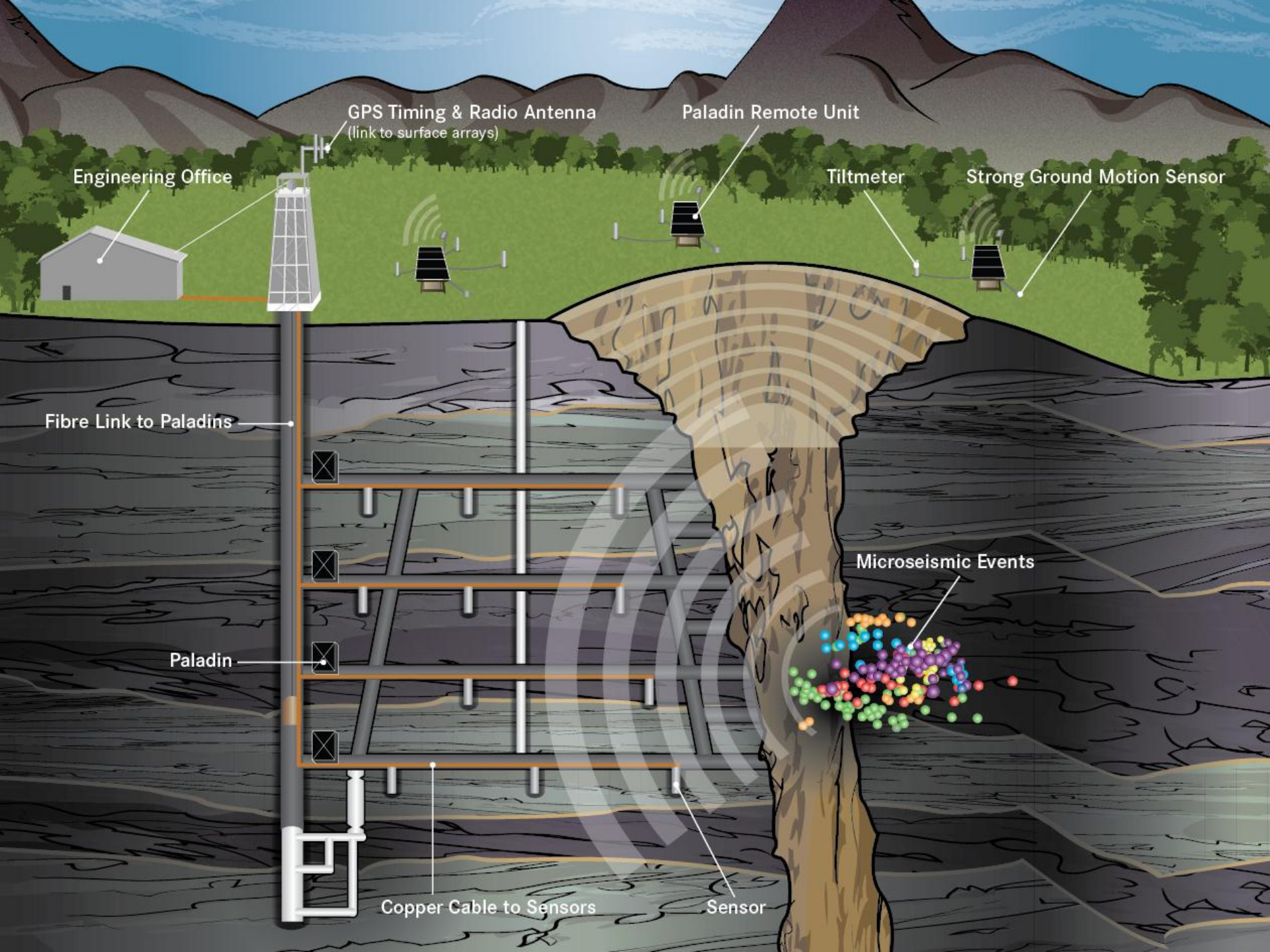

- Transition from First Arrival based systems to continuous 24 bit resolution data recorders over the past 30 years



Intrinsically Safe MSHA-certified seismic system configuration

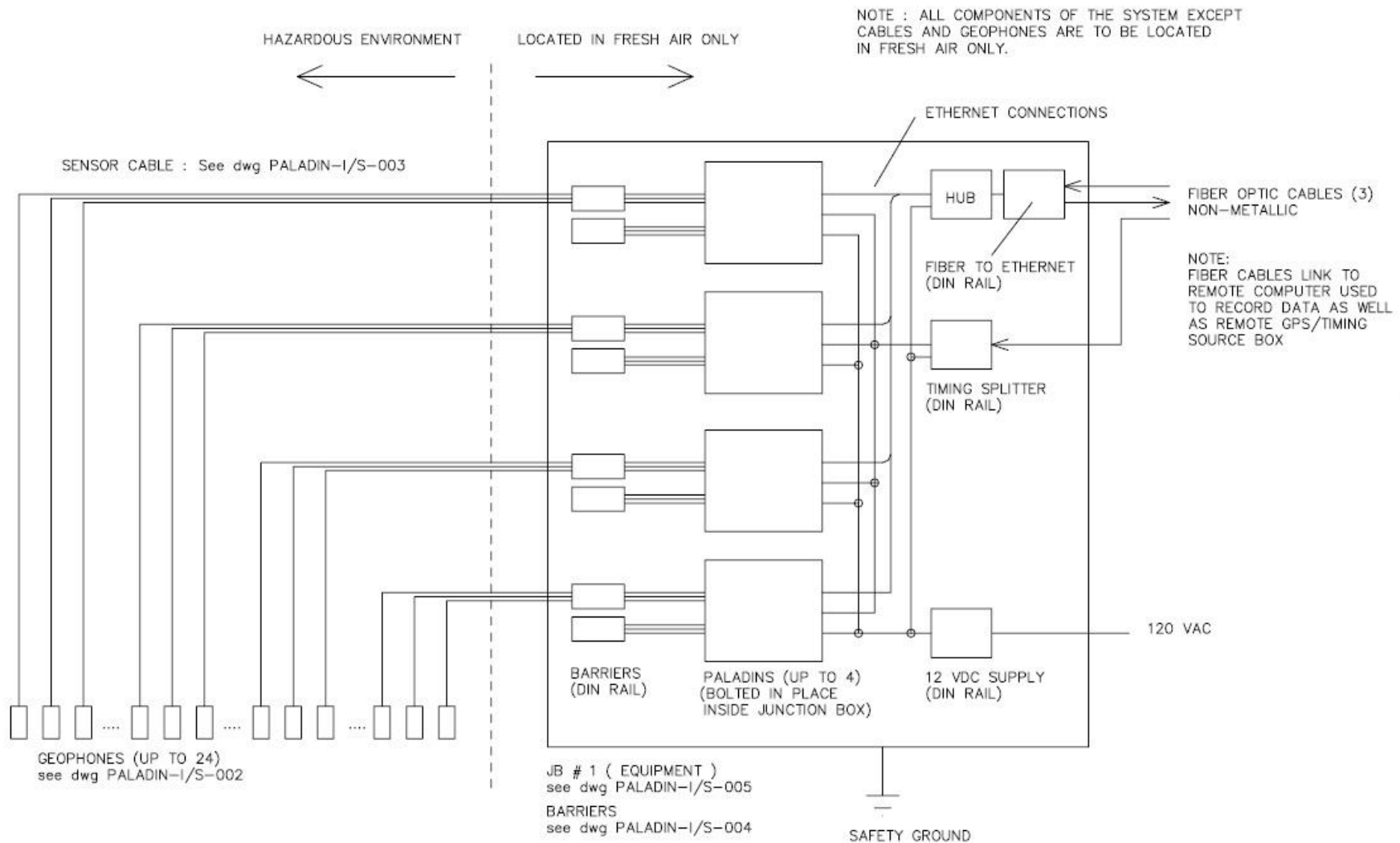

Seismic recorders must be located in ventilated, fresh air areas

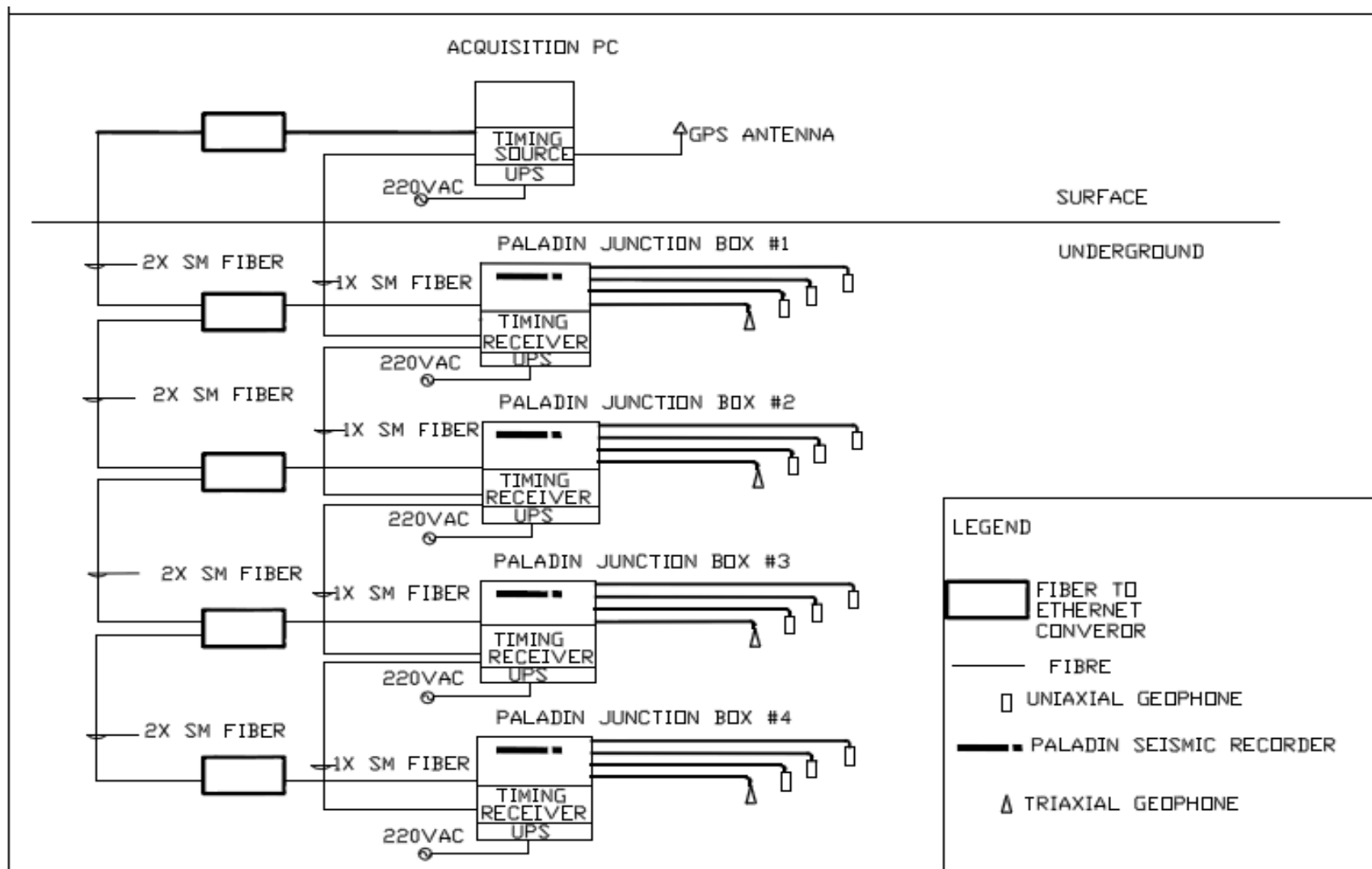

The IS barriers are installed inside explosion proof junction boxes, which allow seismic recorders to be located in non-ventilated areas

- To evaluate the type and sensitivity (minimum magnitude detection) of the sensor array
- To determine sensor array configuration for minimum cost and optimum performance

Elevation 630m – XY

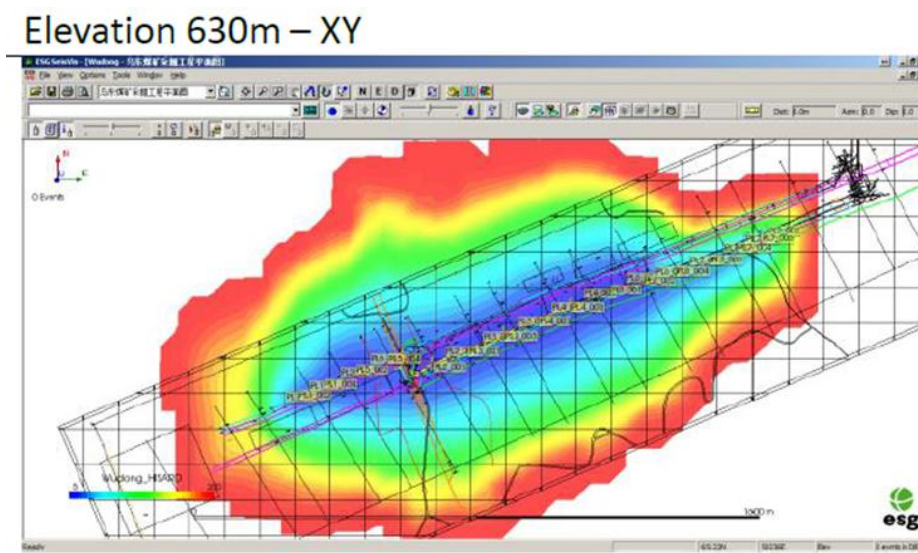

Elevation – XZ

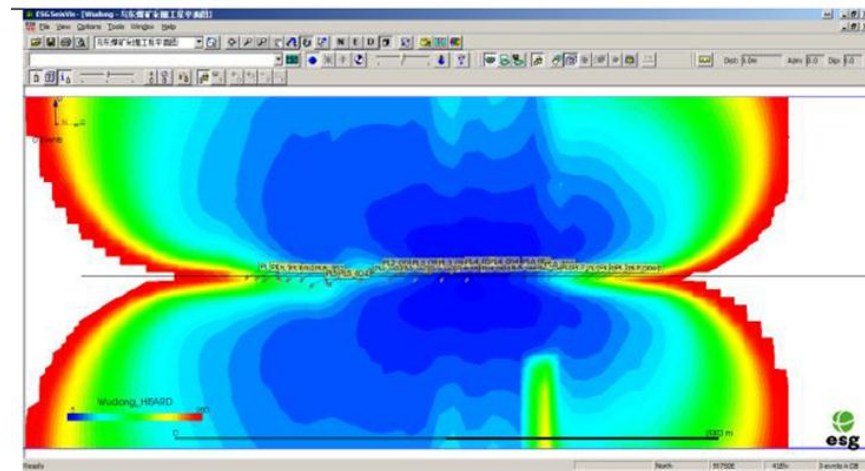

Challenges

- Loss of high frequency signals in coal which is softer than hard rock with lower wave velocities
 - Install geophones rather than accelerometers
- Most coal mines have a sub-horizontal working level that moves forward rapidly
 - Utilize a few triaxial sensors in addition to uniaxial sensors

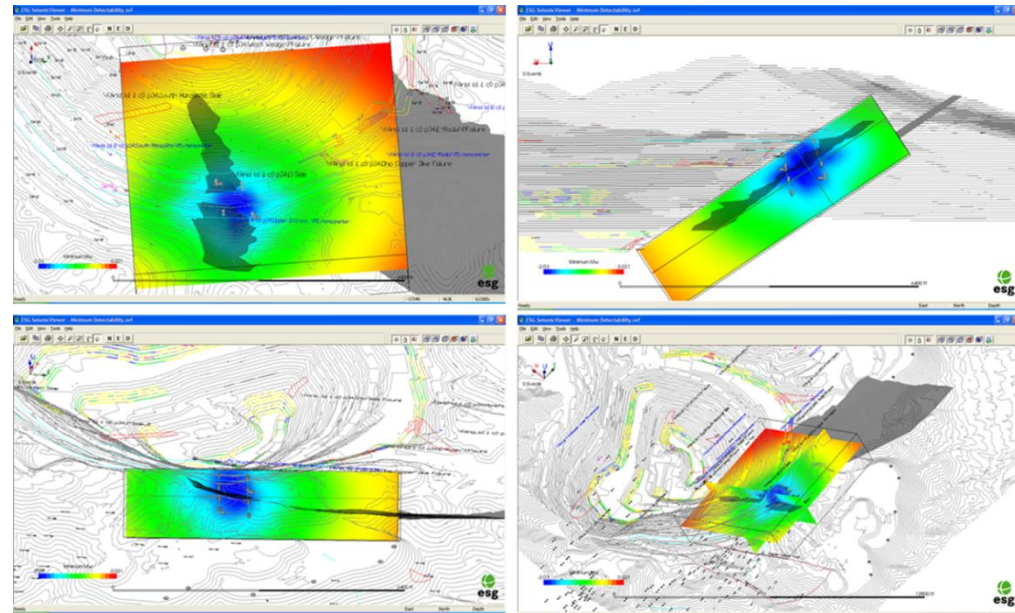

Typical waveforms and amplitude spectra- Mw -0.3 event- Wudong mine

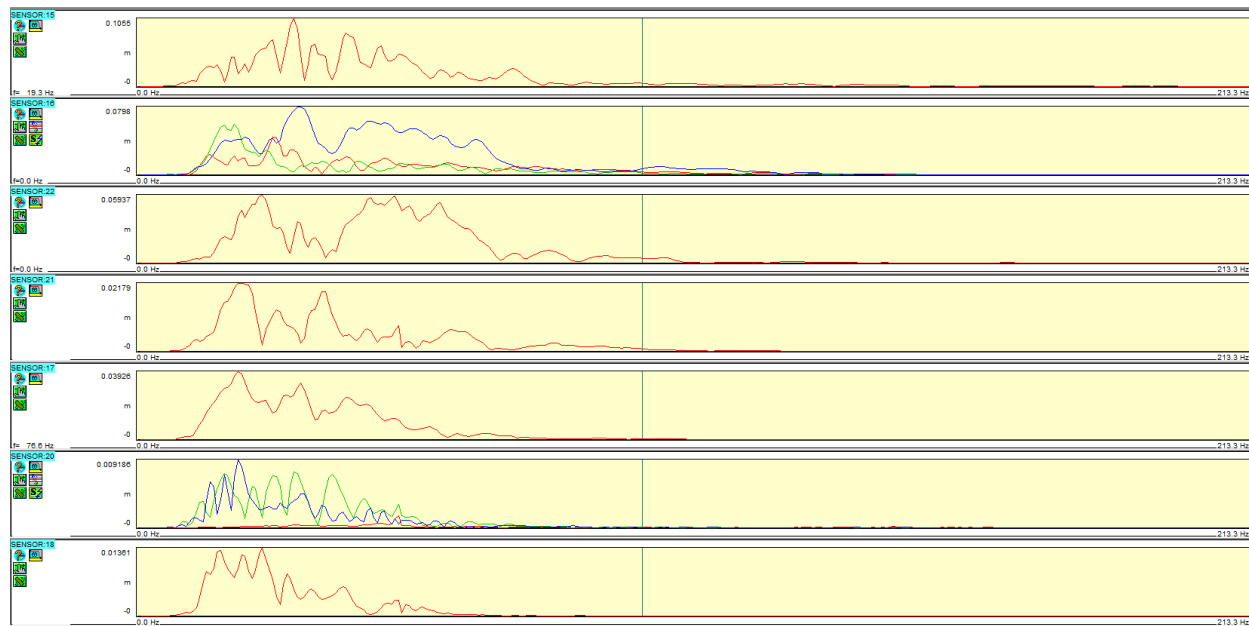
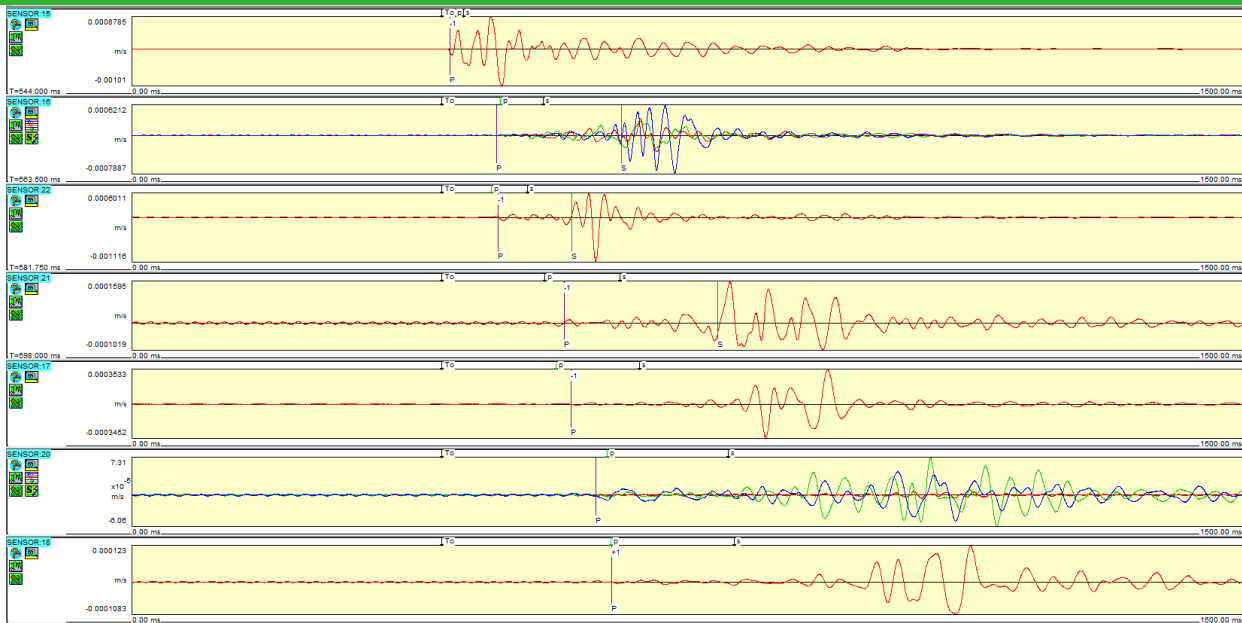

Geophone array at Wudong coal mine

- 12-ch system
- 150 m spacing between sensors
- To monitor magnitude between -1.5 to 2

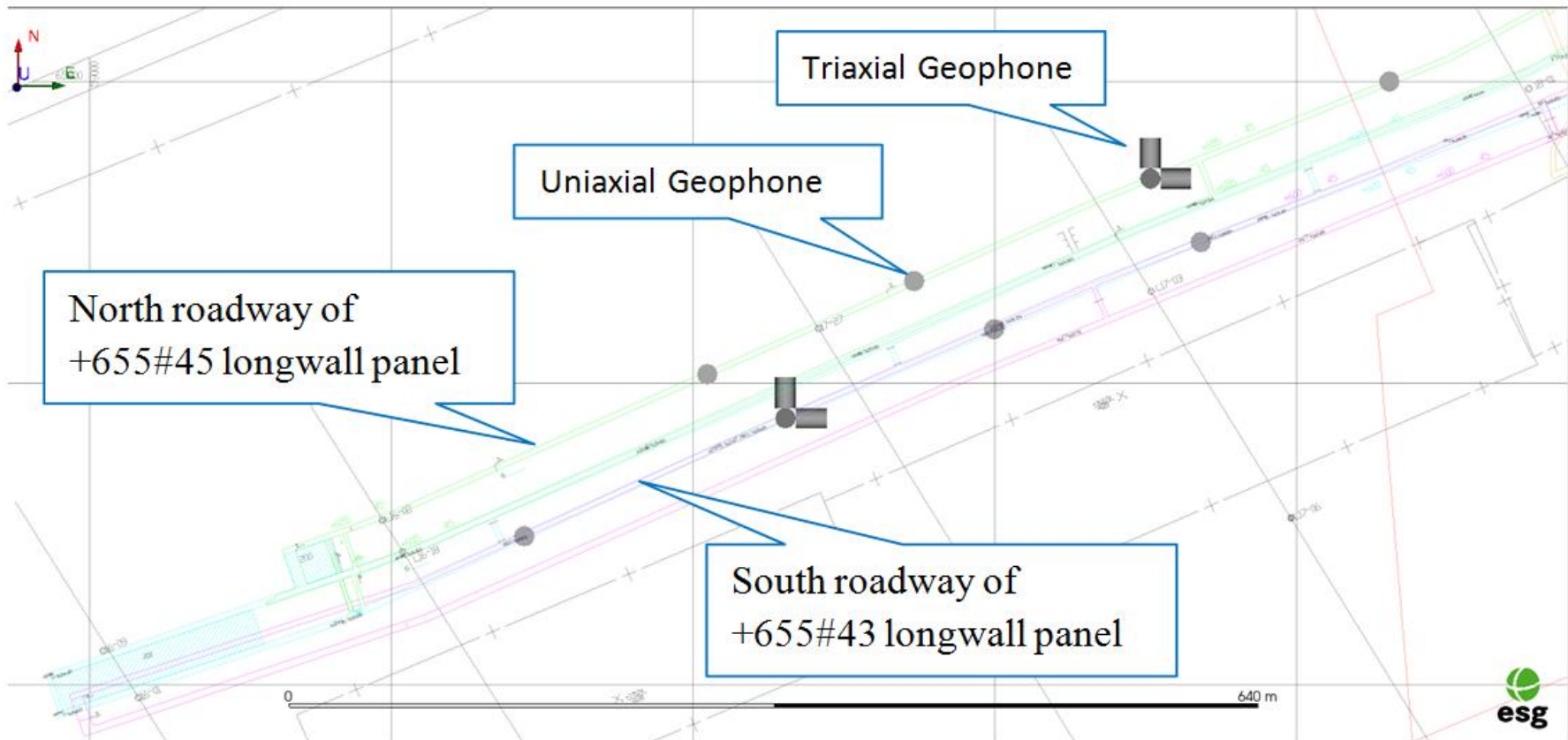

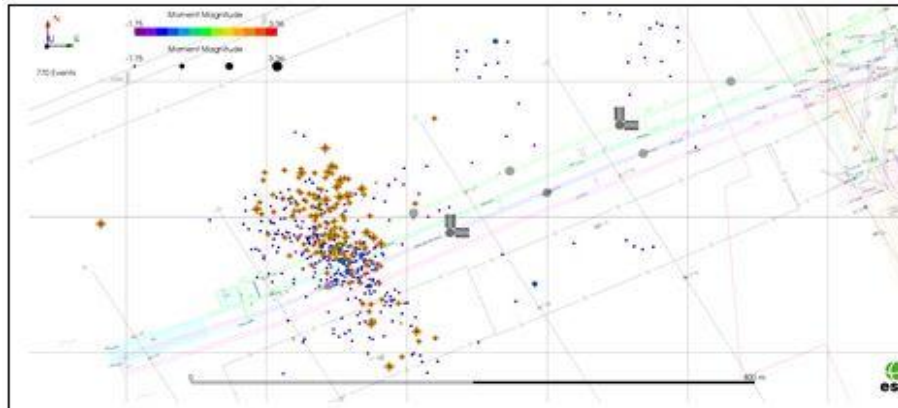

From 2011-9-1 to 2011-9-30

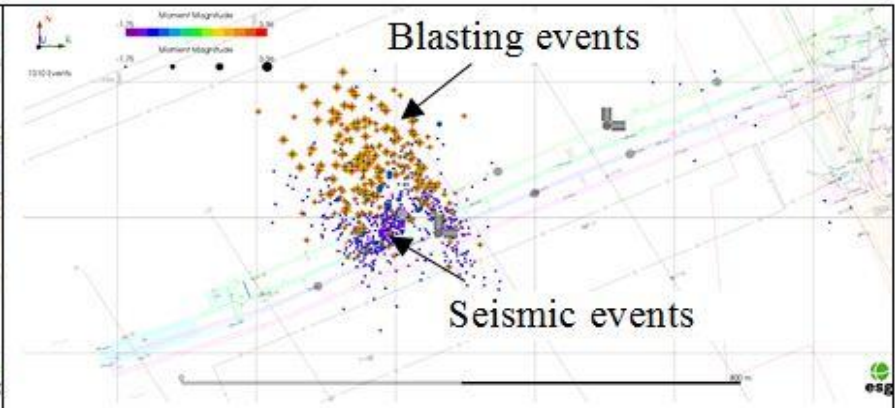

From 2011-10-1 to 2011-10-31

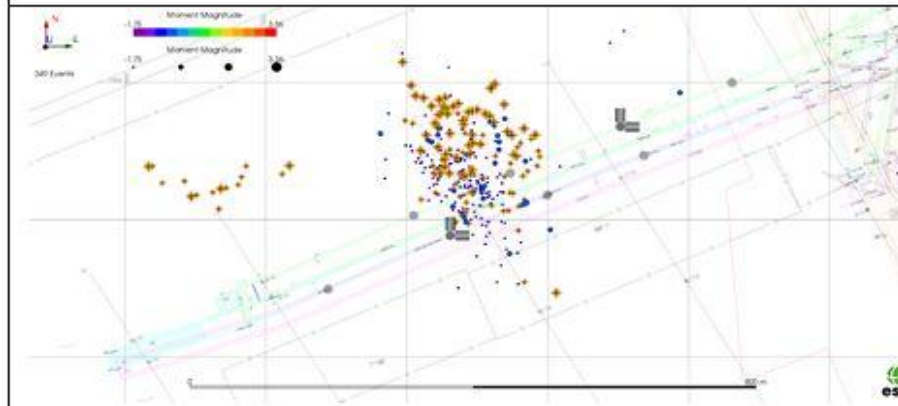

From 2011-11-1 to 2011-11-30

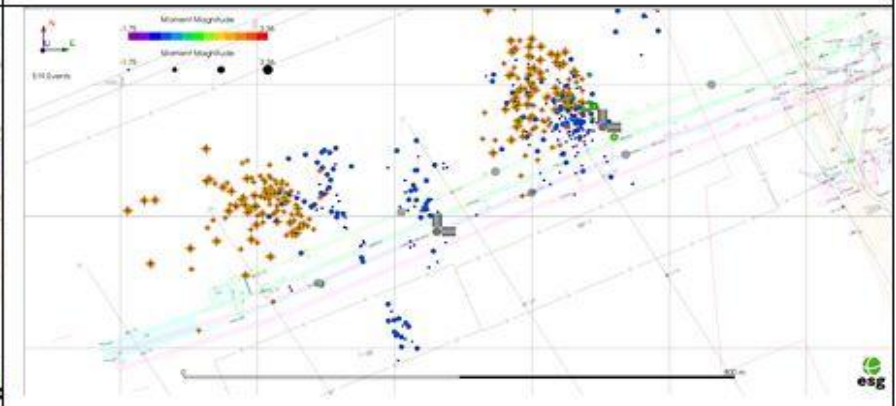

From 2011-12-1 to 2011-12-31

September to December 2011

[3-D Seismic Viewer](#)

- Methane Gas Drainage optimization using microseismic monitoring in Xinzhuangxi coal mine

O-Shape Circle Theory

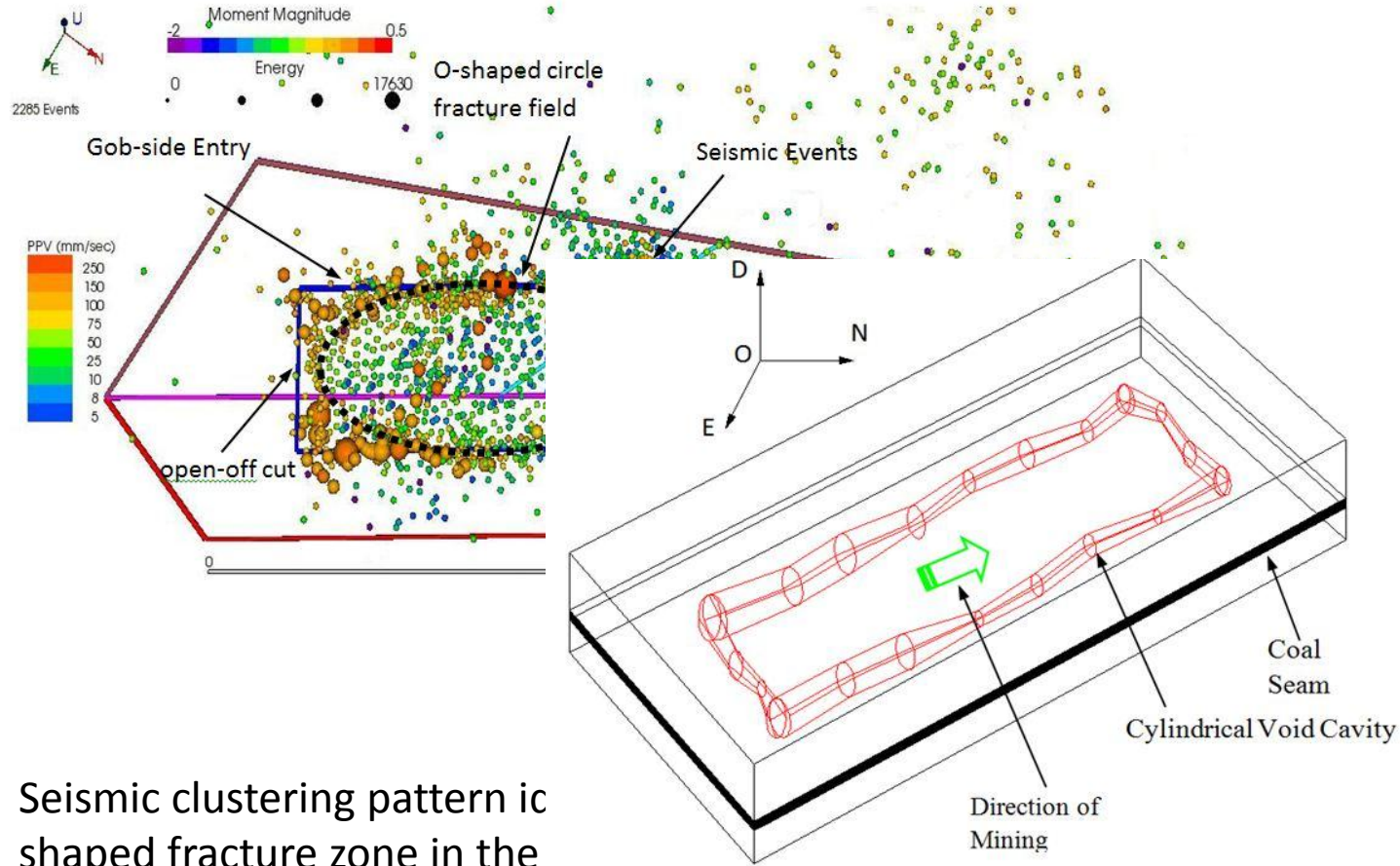

Seismic clustering pattern is O-shaped fracture zone in the Xin Zhuangzi coal mine, matching the O-shape circle theory (Yuan and Eiu (2003))

Gas drainage rate and purity after optimization

- Gas drainage rate improved from 3-8 to 5-15 m³/min
- Gas purity improved up to 50% without additional drilling costs

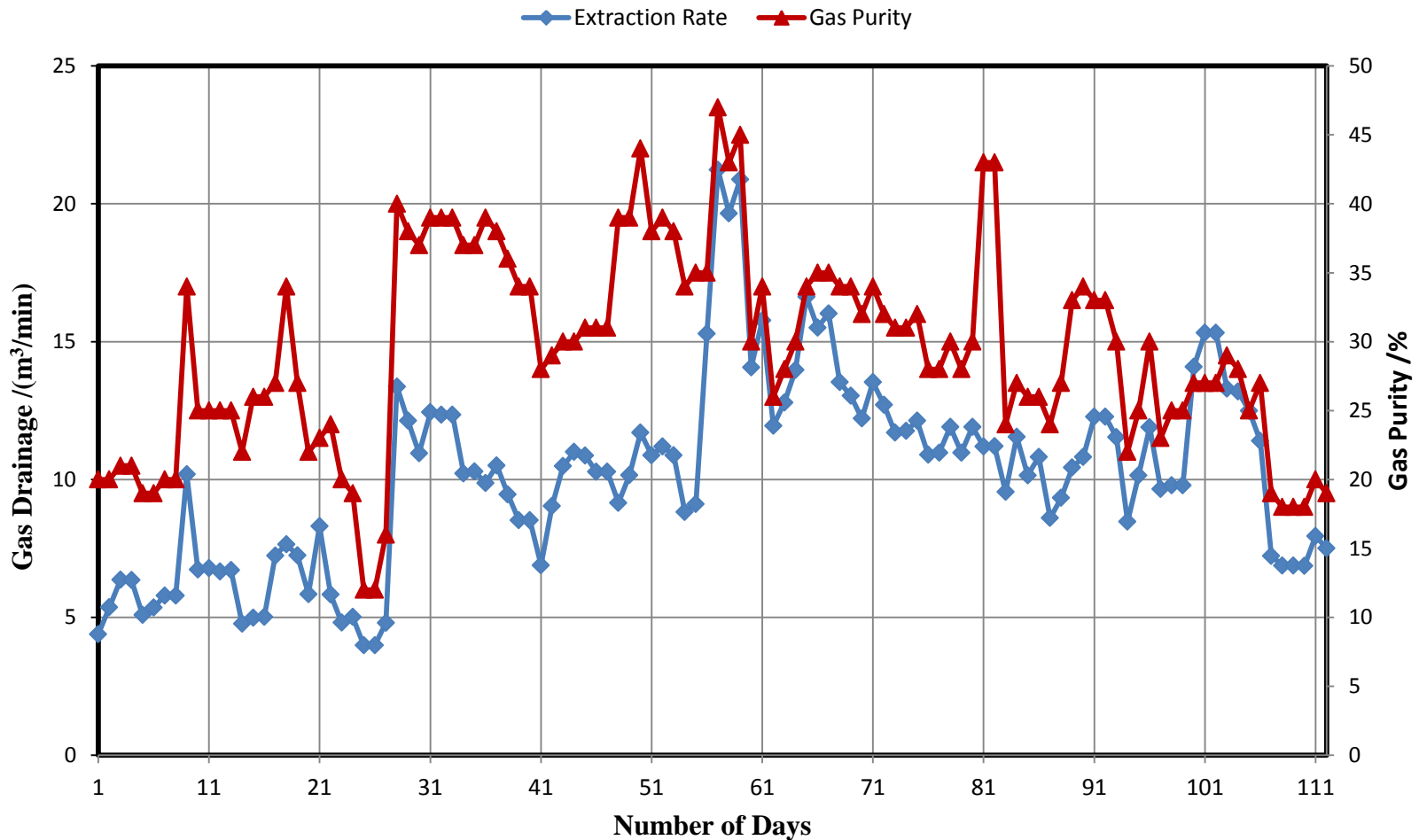

- Identifying geological structures using microseismic monitoring in Xinzhuangxi coal mine



A two-dimensional survey indicates the presence of two faults at Xinzhuangzi mine

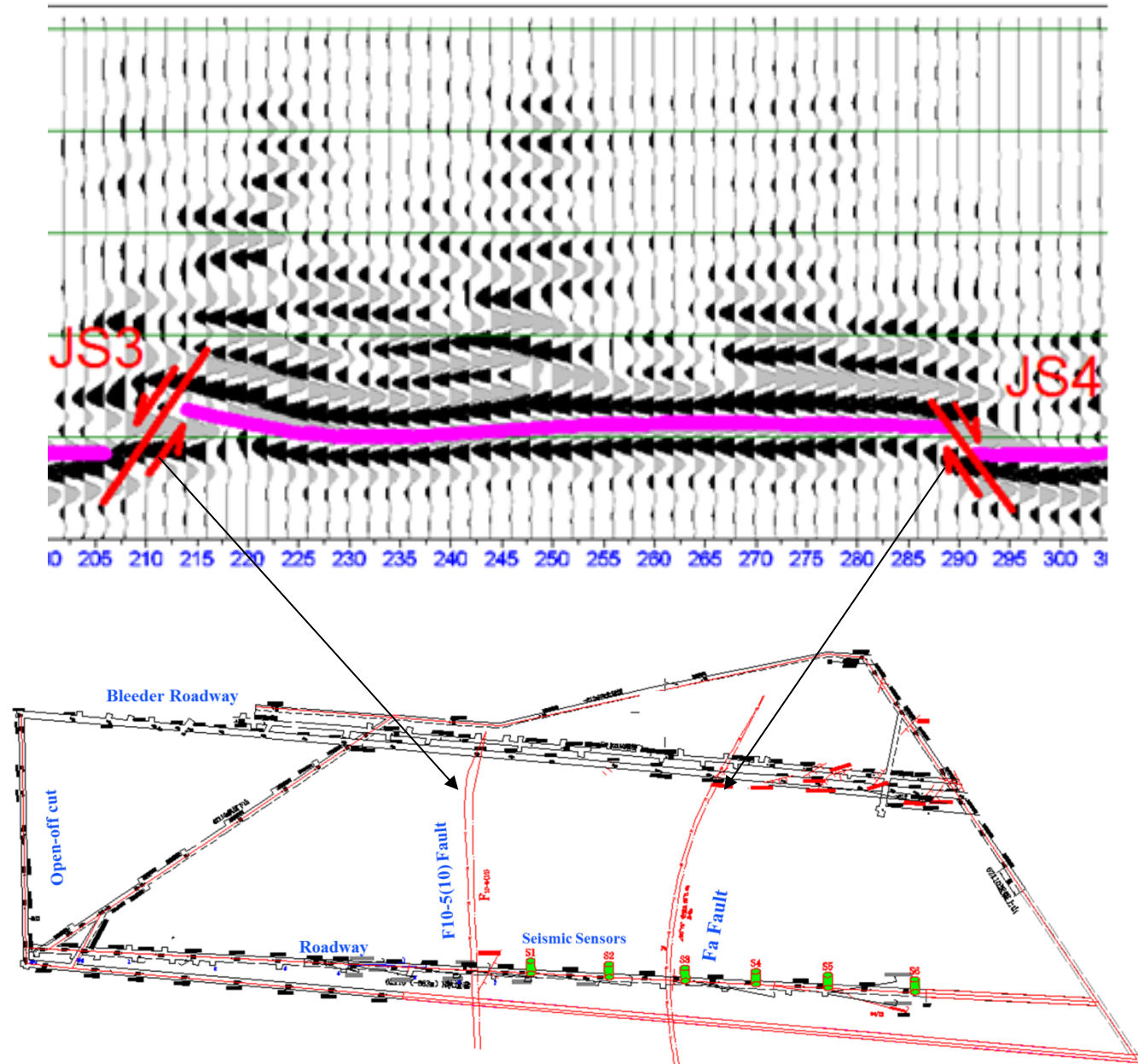

Seismicity as of April 29

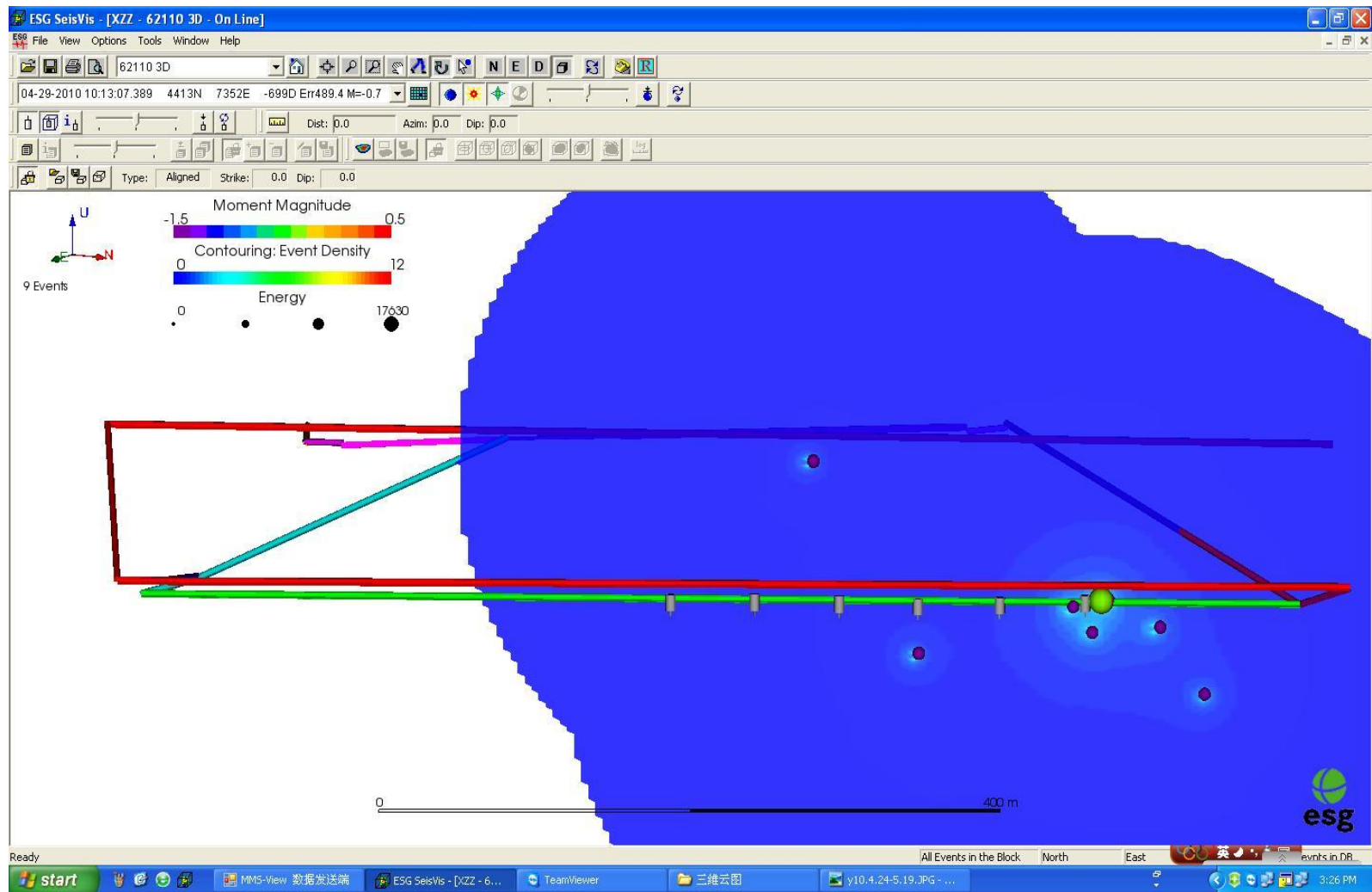

2010.4.29 Seismic Event at Xinzhuangxi Coal Mine

Accumulated seismicity up to May 3th

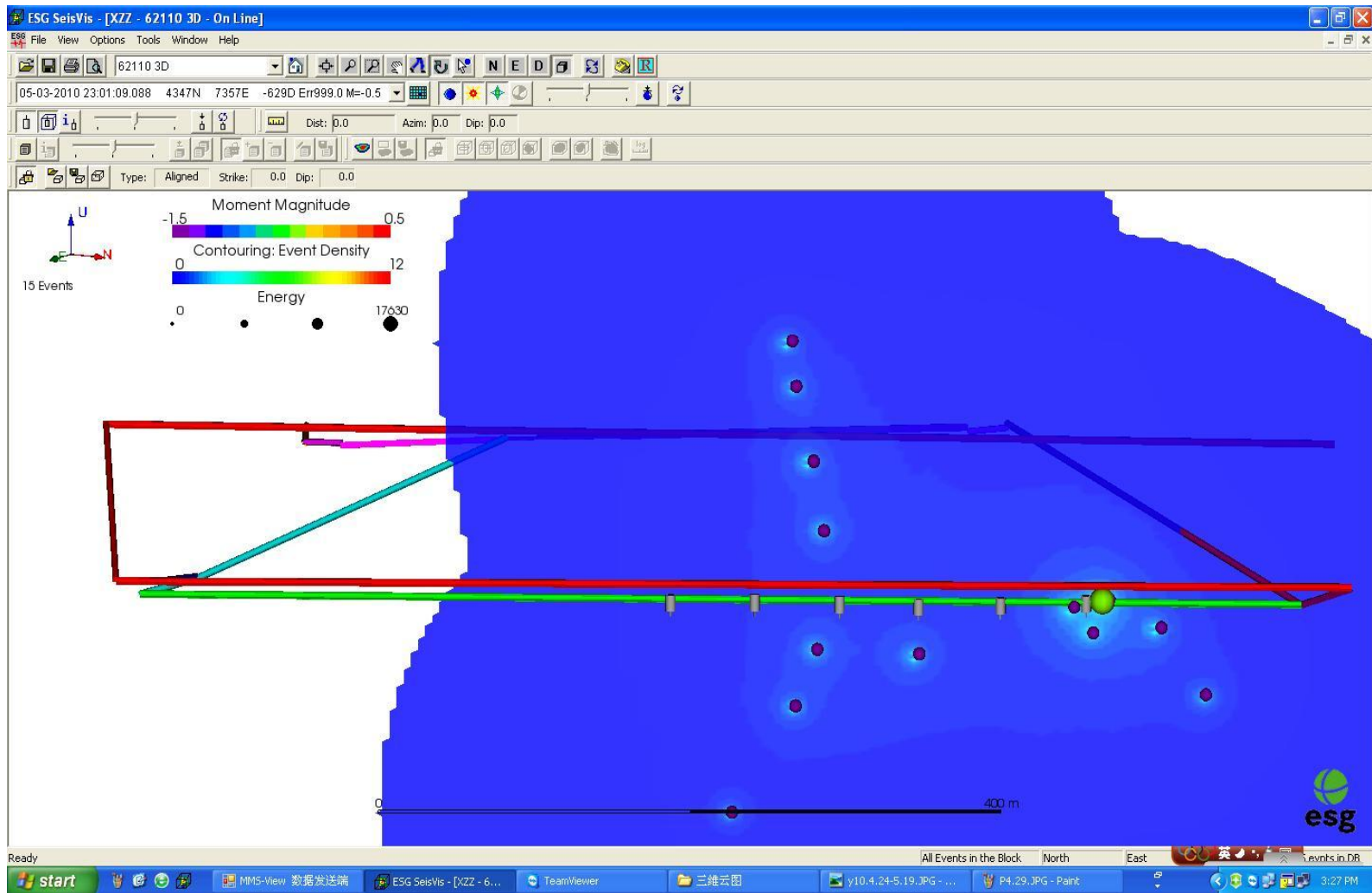

From 29/4/2010 to 3/5/2010 Seismic Event at Xinzhuangxi Coal Mine

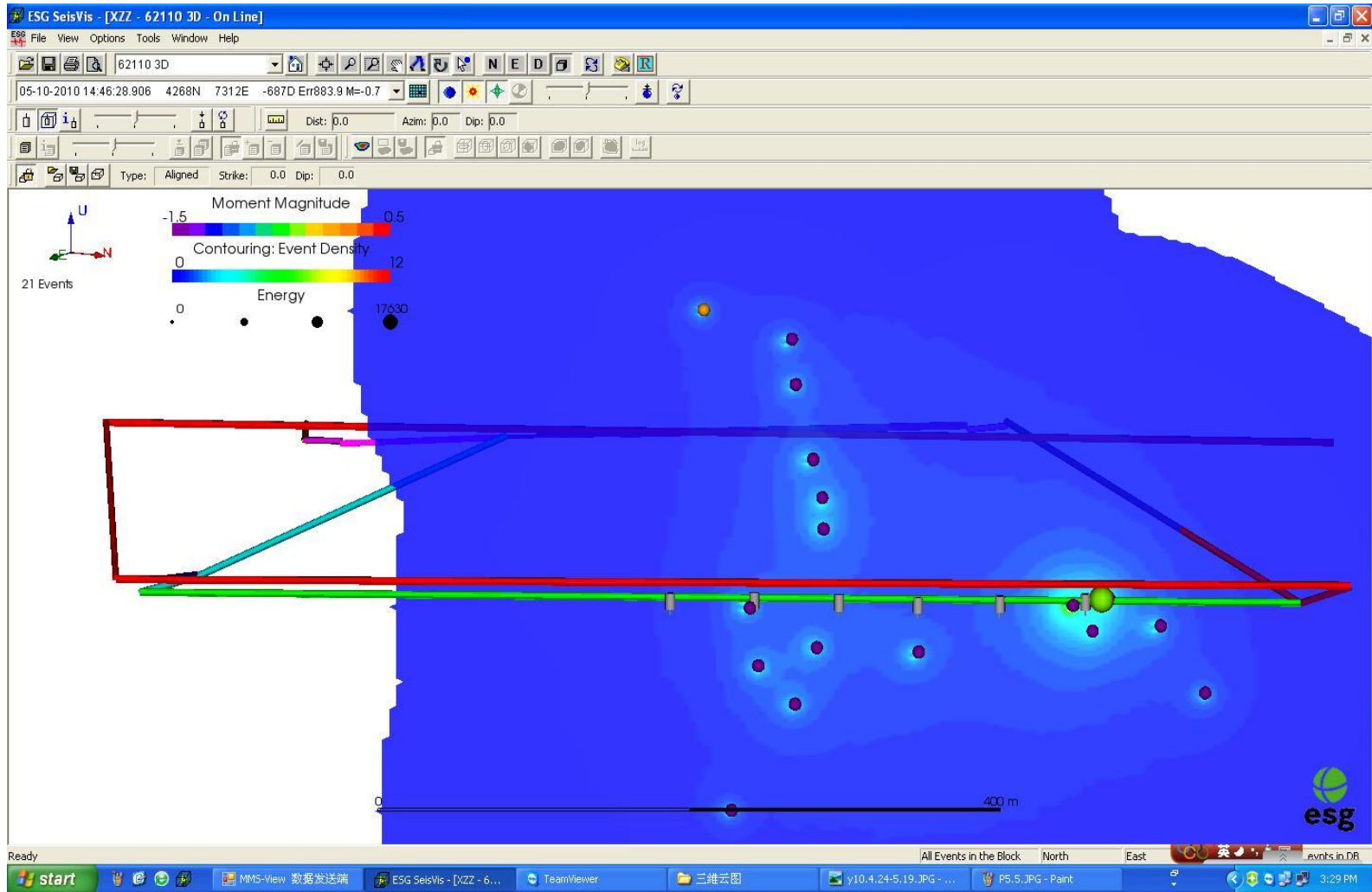

To 10/5/2010

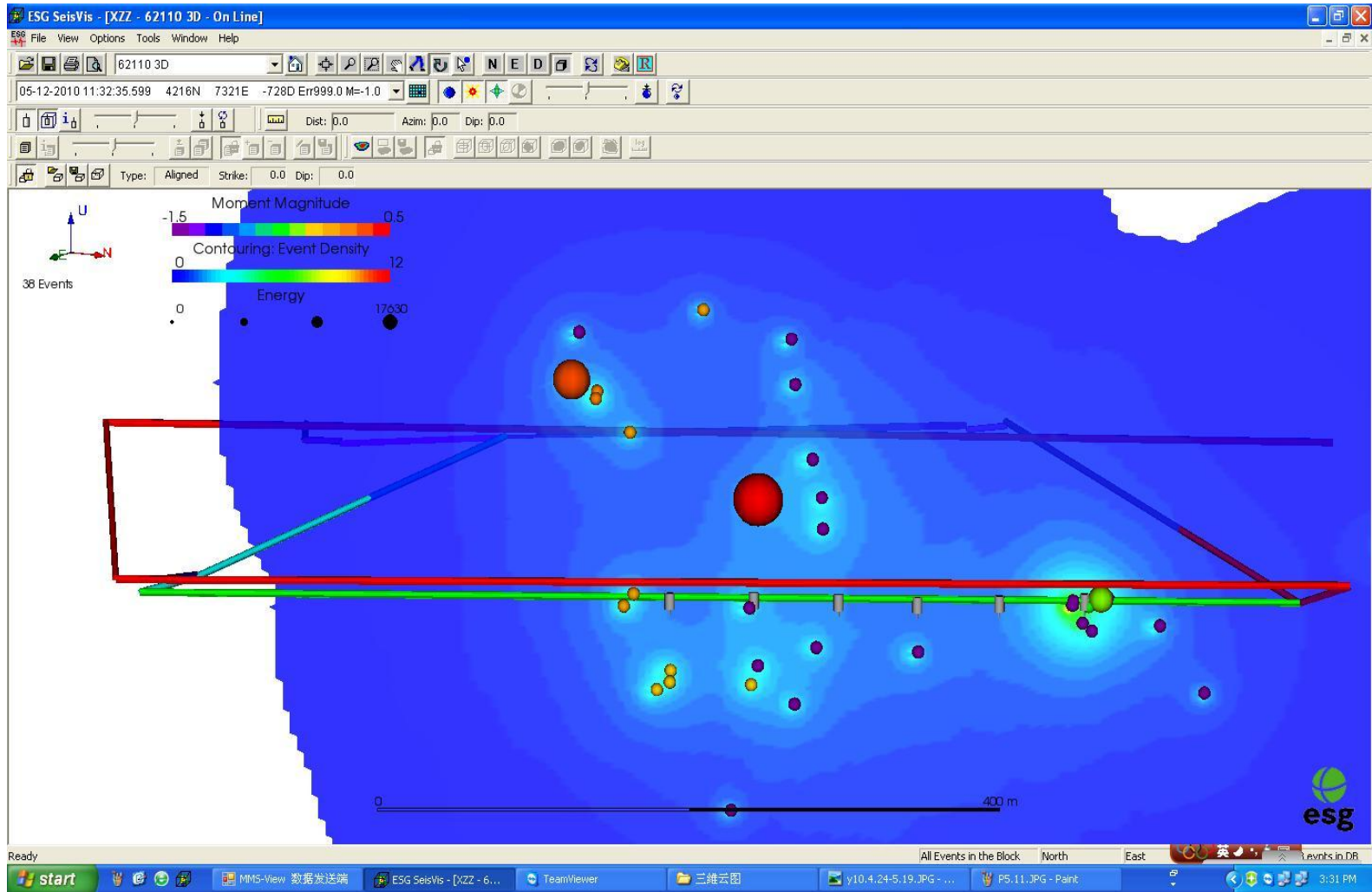

To 12/5/2010

Up to May 16th

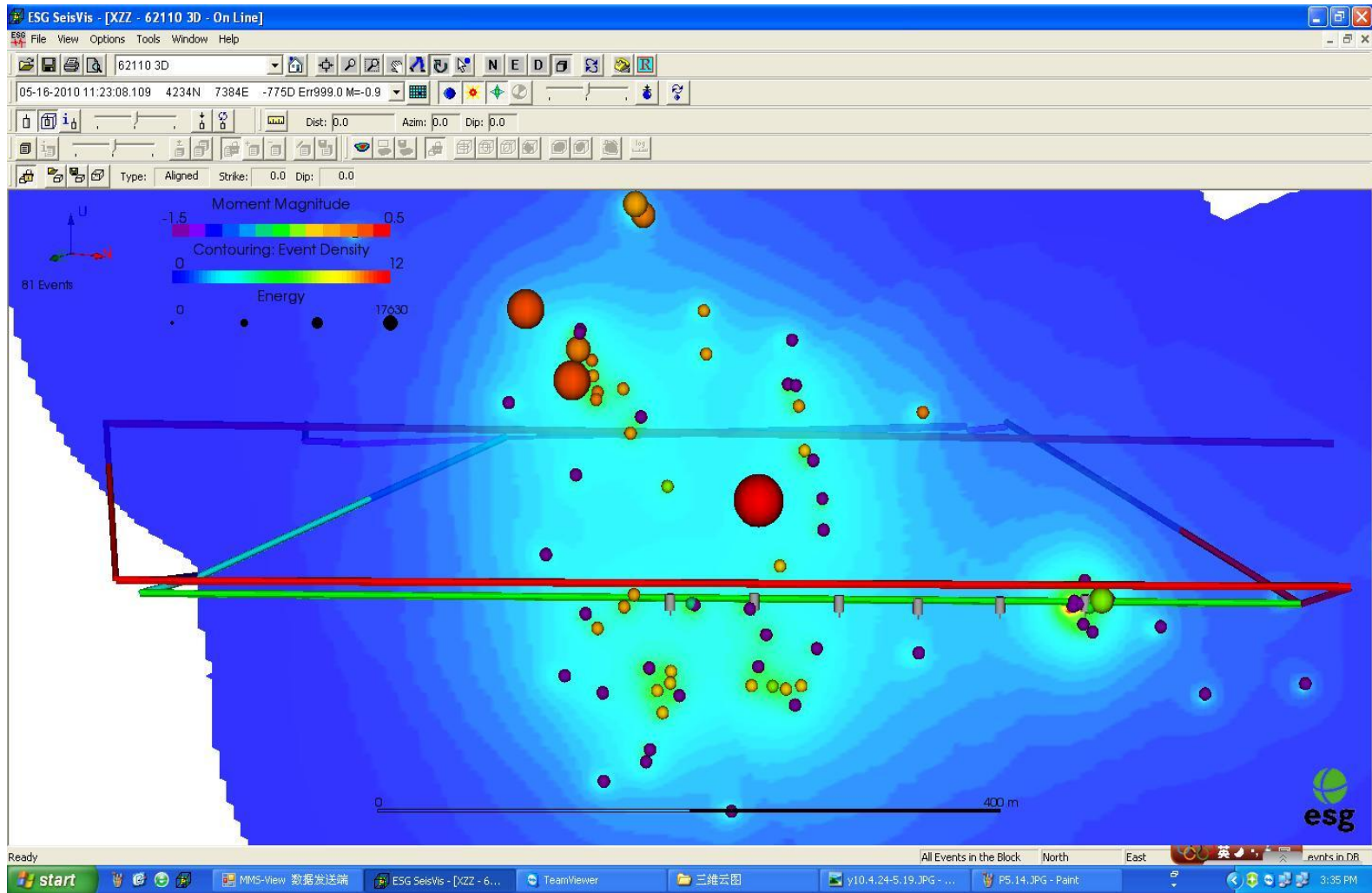

To 16/5/2010

Up to May 18th

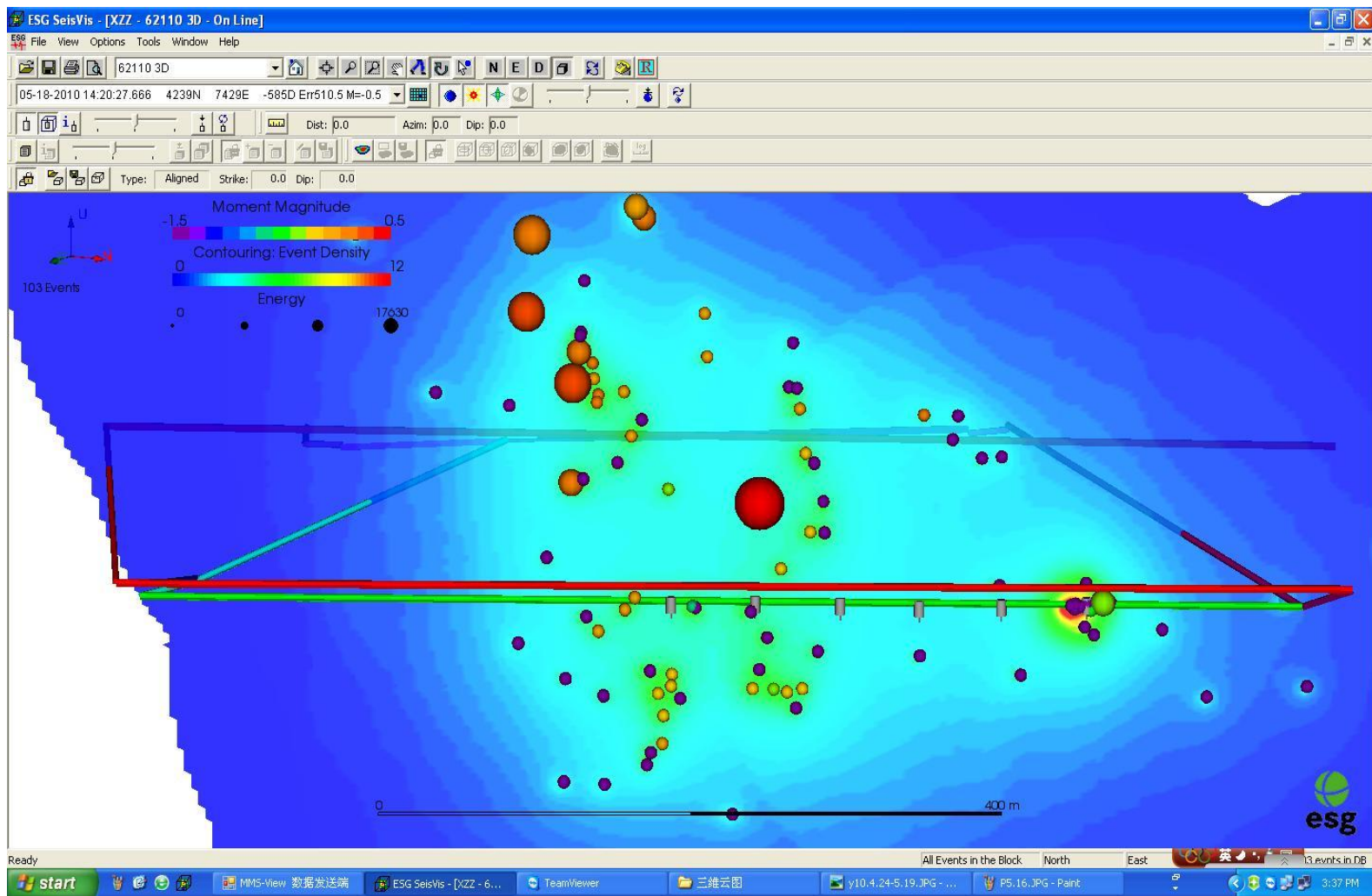

To 18/5/2010

Up to May 20th

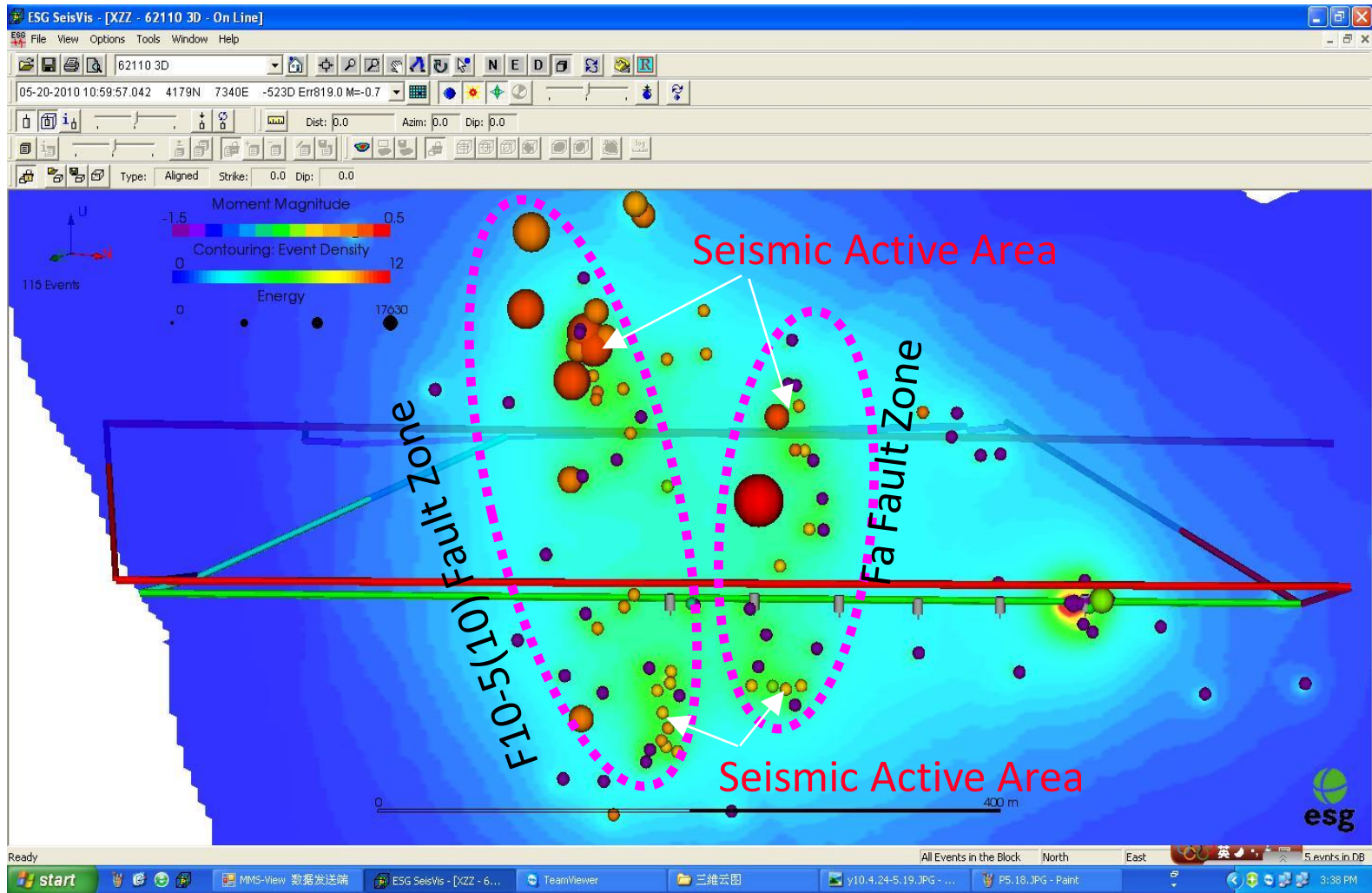

To 20/5/2010

Up to May 24th

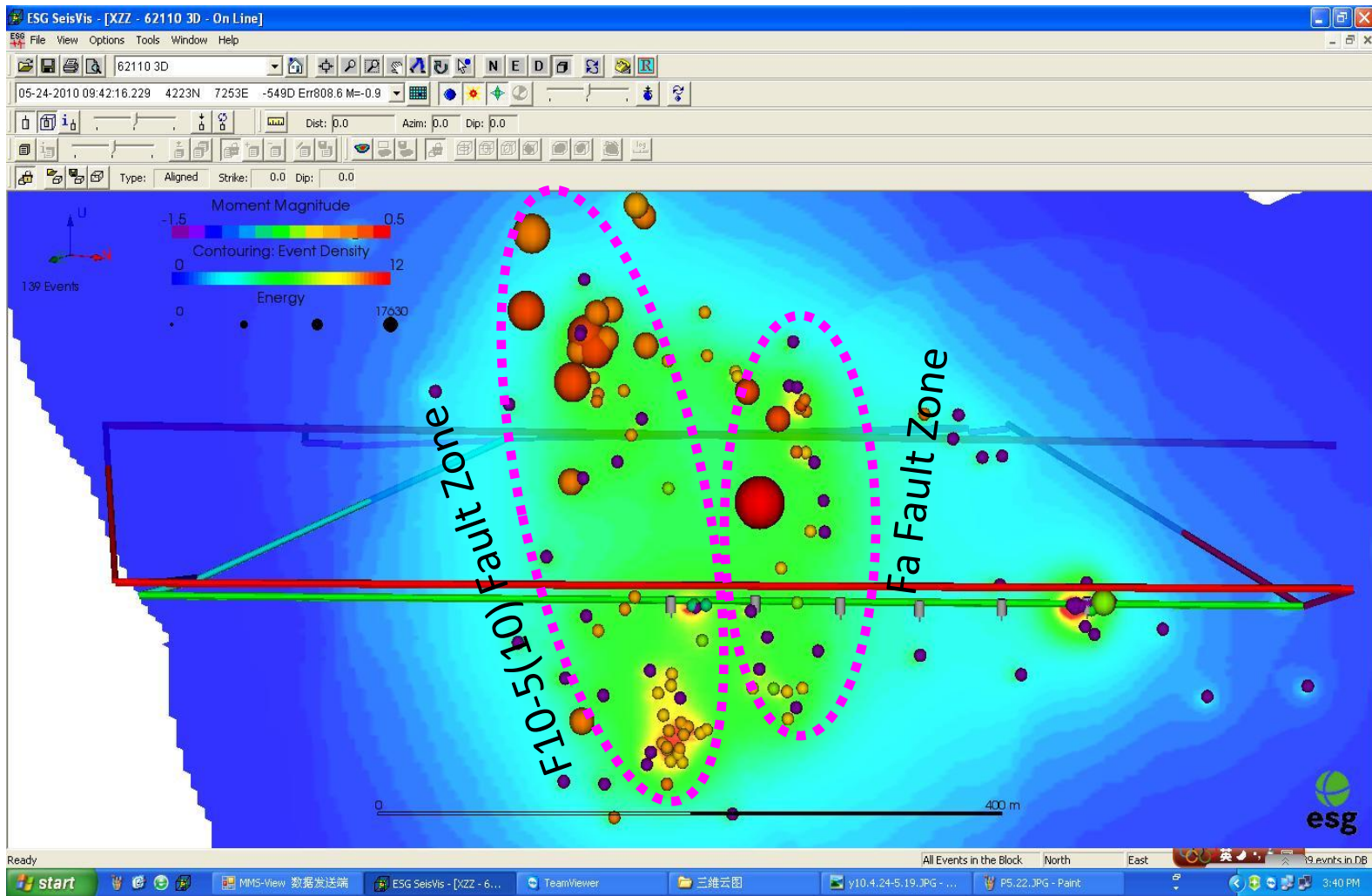

To 24/5/2010

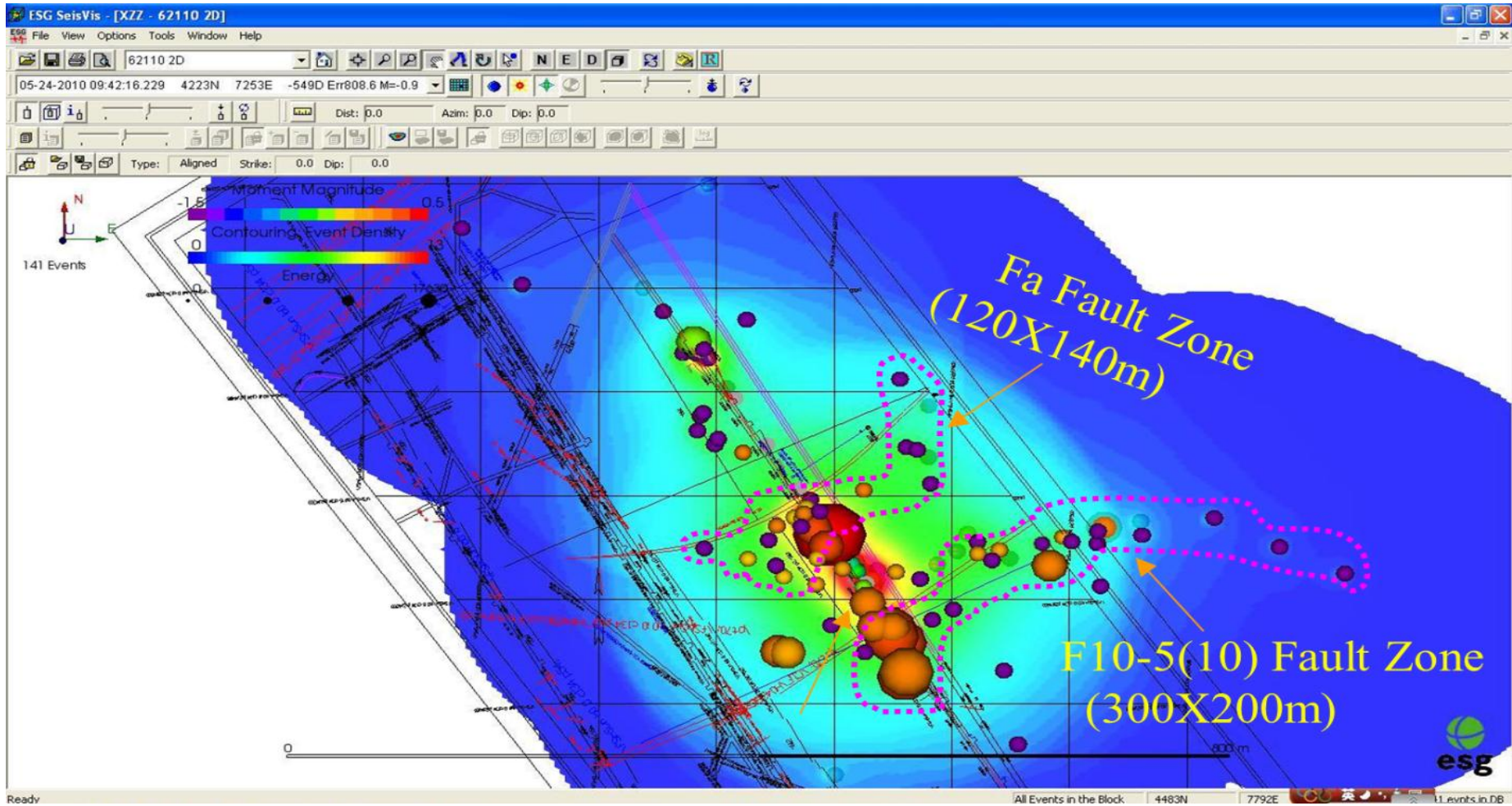

Seismic moment density evaluated from microseismic source parameters for events in the areas of the Fa and F10-5(10) faults at Wudong coal mine

- Seismic monitoring in coal mines can be challenging due to the limited mining elevation, and softer rockmass
- The advances in technology, seismology theory and powerful computers better allow recording and analysing seismic events in challenging media
- Seismic monitoring over time can help better explain the rockmass reaction to mining activities
- The history of data can be used to identify high stress zones, unknown or seismically active geological structures, and gas concentration zones

Thank You

