

AN INTEGRAL BALANCE PISTON FOR CENTRIFUGAL PUMP PUMP IMPELLERS

by

Kevin Fairman

Senior Project Engineer

and

William J. Mabe

Manager, Engineering Services

Sundstrand Fluid Handling

Arvada, Colorado



Kevin Fairman is a Senior Project Engineer in the Development Engineering group at Sundstrand Fluid Handling in Arvada, Colorado.

Since joining Sundstrand, he has been involved in high speed pump and sealless pump projects, with particular emphasis on thrust balance systems.

Prior experience includes pump test engineering at the engineered pump division of Ingersoll-Rand and five years as

a centrifugal compressor design engineer at Ingersoll-Rand in Phillipsburg, New Jersey.

Mr. Fairman has received his BSME degree from the University of New Hampshire.



William J. Mabe is Manager of Engineering Services for Sundstrand Fluid Handling, where he is primarily responsible for new product development of high speed, gear driven pumps and compressors. Mr. Mabe joined Sundstrand Fluid Handling Division in 1974, as a Senior Engineer involved in inducer and centrifugal pump design. In addition to product development, Mr. Mabe has been responsible for CAD and CAE implementation in the Engineering Services area. Previous pump and turbine experience includes six years at Rocketdyne, Liquid Rocket Division of Rockwell International, where he was a member of the technical staff responsible for the space shuttle turbopump design.

Mr. Mabe holds a B.S. degree in mechanical engineering from the University of Missouri at Rolla and is currently a member of the American Society of Mechanical Engineers. Mr. Mabe is also a member of the International Pump Users Symposium Advisory Committee.

ABSTRACT

Axial thrust balancing of pressure forces in centrifugal pumps has long been a design challenge for pump engineers. This becomes particularly important in sealless pumps, due to their lack of thrust bearing capacity, and increasingly difficult in high speed pumps, as stage pressure rise is increased. Many thrust

balancing configurations have been used including devices such as balance pistons which can compensate for variable conditions. Separate balancing devices, however, add significant disc friction power and require excessive leakage flow, both of which reduce efficiency. A unique thrust balancing device has been developed which integrates the balance piston with the impeller shrouds. This patented device achieves self-compensating thrust balance in addition to minimizing overall leakage and disc friction power.

A detailed description of the integral balance piston is presented. Technical features and performance calculations are supported by development test results and operating field experience.

INTRODUCTION

In addition to leakage concerns, a pump designer must address the issue of hydraulic thrust. Without special design features, it is a well known characteristic of centrifugal pumps that thrust loads of substantial magnitude can be produced which must be supported by bearings on the impeller shaft. This thrust is caused by exposure of the front and rear shrouds of the impeller to high pressure generated at the impeller tip. The area exposed to these high pressures is typically greater on the back side of the impeller, than on the front side, resulting in a net out thrust. A high speed pump, for example, generates higher axial thrust than similar geometry at a lower speed. The increased thrust loads require heavy duty construction and the use of high capacity thrust bearings. The thrust problem becomes even more difficult because high capacity thrust bearings tend to be larger in size resulting in higher operating temperatures.

In addition to thrust considerations, the design of any pump must minimize impeller leakage losses to achieve maximum performance. Leakage losses become more significant in high speed pumps, since the wear ring clearance is generally a greater percentage of the sealing diameter for small impellers than for large impellers. The ability to develop high pressure levels with a small, high speed impeller, and also have relatively large radial clearances, limits the efficiency improvement potential. This phenomena becomes even more important in the design of low flow pumps, where the leakages are a greater percentage of the total flow.

Various design features such as wear rings or balance ribs have been used in efforts to limit leakage and reduce or eliminate thrust loads. One well known design uses approximately equal diameter wear rings on both the front and rear shrouds of the impeller to reduce hydraulic thrust. In order to prevent rubbing contact, relatively large radial clearances are necessary, which result in high leakage losses. These leakage

losses will increase as the rings wear over a long period of pump operation. Another design which reduces leakage losses utilizes radial balance ribs on the rear shroud. These ribs alter the rear shroud pressure profile, thus reducing the thrust loads to levels within the capacity of the thrust bearings. Frequently, use of such radial ribs is not permitted because an axial shift of the impeller shaft alters the effectiveness of this type of structure.

Centrifugal pumps have also been designed with balance drums or balance discs to control thrust. A balance drum structure has large radial clearances resulting in high leakage loss, and embodies fixed geometry so that only approximate thrust balance can be achieved. Balance discs, on the other hand, utilize variable geometry to achieve full thrust balance. These balance discs have been used successfully in multistage pumps. The balance disc, however, is an additional component which operates at the expense of added leakage and disk friction power. An advanced balance means utilizing a balance disc integral with the impeller, has been reported [1]. As shown in Figure 1, oppositely directed axial seals at the impeller periphery and near the hub act in cooperation to provide thrust balance. This geometry is currently in use on the space shuttle main engine fuel turbopumps [2]. It should be noted that all of the above thrust balancing methods generally use radial wear rings on the front shroud at the impeller eye.

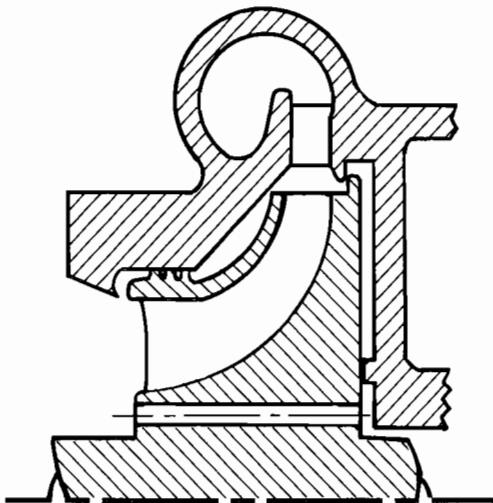

Figure 1. Space Shuttle Main Engine Turbopump Impeller.

In order to achieve thrust balance with minimum leakage losses, an integral balance piston design has been developed [3], which utilizes an axial sealing face at the impeller eye as shown in Figure 2. This balance system is referred to as tandem axial thrust control or TATC. The following is a detailed description of the TATC system and a discussion of the effects of various design and fluid parameters. Important technical features of the TATC system are presented as well as force balance and leakage analysis, stiffness characteristics, and effects of externally applied thrust loads. Data from the development test program are included to illustrate the dynamic response of the system. Application to sealless pumps and a summary of field experience are also discussed.

DESIGN FEATURES

The tandem axial thrust control (TATC) system consists of two main features, an integral balance piston and an axial front impeller seal.

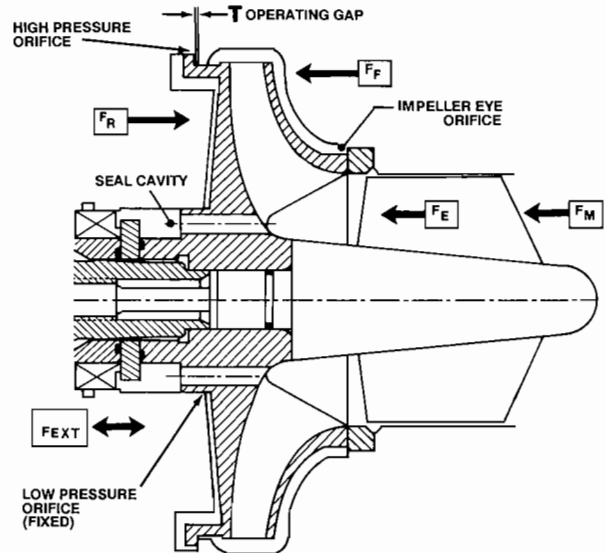

Figure 2. Layout of Tandem Axial Thrust Control System with Fixed Low Pressure Orifice.

Integral Balance Piston

The TATC utilizes opposed mating surfaces at the impeller periphery and a restricting orifice at the impeller hub as shown in Figures 2 and 3. The area between these orifices is the integral balance piston which may be referred to as the "rear shroud cavity." The mating surfaces at the impeller periphery will be referred to as the "variable high pressure orifice." The restriction at the impeller hub is the "low pressure orifice." This orifice may be fixed, dependent upon a fixed radial clearance (Figure 2), or variable, a function of rotor axial position (Figure 3). The high pressure supply for the integral balance piston is the static pressure at the tip of the impeller. Process fluid flows through the high pressure orifice, through the rear shroud cavity and the low pressure orifice, and empties into the seal cavity. The seal cavity is vented to the impeller eye by way of balance holes or an external line.

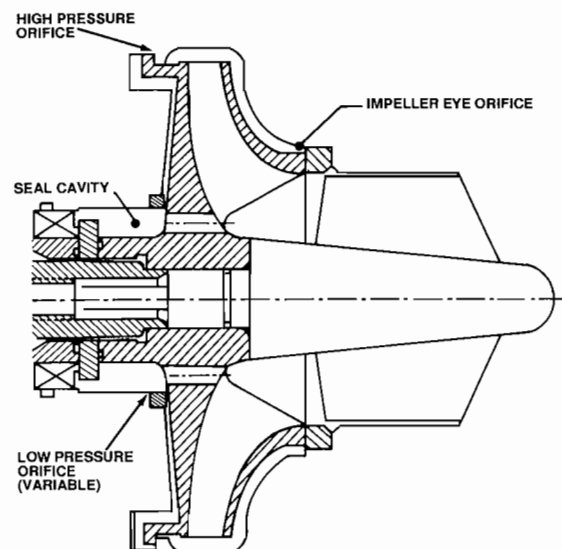

Figure 3. Layout of Tandem Axial Thrust Control System with Variable Low Pressure Orifice.

Proper function of the TATC requires that the impeller and shaft assembly be free to shift axially as required for thrust balance. Thrust bearings must not restrict rotor axial movement within the operating range of the thrust control mechanism. Any axial restraining forces due to couplings and seals must be within the force balancing capacity of the thrust control device. This requirement makes the TATC especially well suited for integral gear driven pumps and sealless pumps.

Thrust balance in the TATC is achieved by generating forces on the rear of the impeller that are equal and opposite to the sum of all other forces acting on the shaft. The control of these forces is provided by the fluid pressure drop at the high and low pressure orifices. The forces acting on the impeller and shaft are shown on Figure 2. These forces are defined as follows:

Ff	front shroud force
Fe	impeller eye force
Fm	fluid momentum force
Fext	external forces (e.g. seal spring)
Fr	impeller restoring force

At any given operating point, Ff, Fe, Fm and Fext are relatively fixed quantities. A restoring force, Fr, is required to complete the thrust balance. This restoring force is created by the variable pressure acting over the rear shroud of the impeller.

As an example, consider the case where an external force, such as a sudden increase in suction pressure, pushes the rotor toward the rear. As the impeller and shaft assembly move back, the axial clearance at the high pressure orifice is increased, resulting in a reduced pressure drop and an increased flowrate. At the low pressure orifice, there is an increase in pressure drop due to the flow increase. The net result is that the pressure on the rear shroud is increased, producing a change in forward force that will serve to balance the external force at a new axial position. Conversely, a forward acting thrust force, such as a reduction in suction pressure, will tend to decrease the axial gap at the high pressure orifice. This has the effect of throttling the flow that passes through the rear shroud cavity. This reduction in flow will decrease the pressure drop at the low pressure orifice. The net result is lower pressure on the rear shroud, and, therefore, less forward force will be contributed by the integral balance piston. In this manner, the balance piston continually adjusts axial position to provide balanced axial thrust.

The full range of the thrust balance mechanism is dependent upon the difference between the seal cavity pressure downstream of the low pressure orifice and the impeller tip static pressure. As the high pressure orifice opens, the pressure on the rear shroud approaches the impeller tip static pressure. As the high pressure orifice closes, the pressure on the rear shroud approaches the seal cavity pressure. Since the entire rear shroud is exposed to this large range of pressures, very large restoring forces are produced. The force range of the thrust control mechanism increases with an increase in the pump pressure rise. High pressures and large diameters generate maximum restoring forces. The sensitivity of the balance piston can be increased by an enhancement as shown on Figure 3. This is a double acting thrust control mechanism typically used in sealless pumps. An axial low pressure orifice that opens as the high pressure orifice closes is used to provide a force balance with less axial excursion than that required by the fixed low pressure orifice design. The axial position of the impeller at thrust equilibrium will be dependent upon the total axial float between the high and low pressure orifices. The force range of the double acting design is generally no greater than that of the fixed orifice style.

The other main feature of the TATC system is the front axial seal which operates in tandem with the integral balance piston.

Front Axial Seal

The axial positional control of the integral balance piston furnishes the means to create an effective axial seal at the impeller eye. A photograph of an impeller showing the front axial seal may be found on Figure 4. The impeller and casing are designed so that the axial clearance between the eye of the impeller and the pump casing is typically 0.001 to 0.002 in when the gap at the high pressure orifice is closed. Therefore, the operating clearances at the impeller eye will always be slightly greater than the operating gap at the high pressure orifice. The tandem action of the high pressure orifice and the impeller eye seal is the unique and patented feature of the TATC. The ability to continually maintain axial operating clearances that are less than typical radial clearances will improve the hydraulic efficiency of the pump. Utilization of the axial sealing design eliminates the need to control leakage with close radial impeller clearances which are more susceptible to rubbing and seizure.

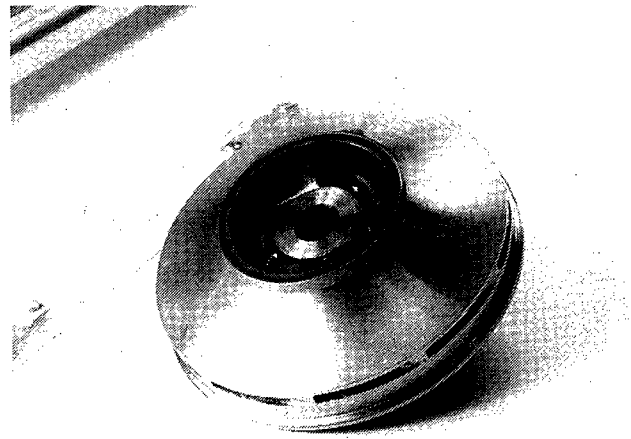

Figure 4. Photograph of the High Speed Test Impeller.

MACHINE AND PROCESS PARAMETERS

With a basic understanding of TATC, one may take a closer look at the pertinent system parameters, the force range, and system response. Machine and process parameters that will impact the TATC are as follows.

Impeller Geometry

For a given pressure rise, the relative differences between the impeller eye, tip, and hub diameters establish the force range of the system. A graphical representation of the pressures and areas that provide the front and rear shroud forces is shown on Figure 5. The equilibrium position, or zero net impeller thrust, exists when the frontside and backside forces are equal, or $Fr = Ff$ at zero suction pressure. The equilibrium pressure differential across the gap, t , at the impeller periphery is indicated as DP1. The pressure differential across the low pressure orifice is indicated as DP2, while the pressure differential across the eye orifice is indicated as DP3.

The maximum force range of the system is shown on the dotted line at $t = x$ and $t = 0$, where x is the total axial float. The difference $Fr - Ff$ at $t = x$ will provide the maximum forward thrust. The difference $Ff - Fr$ at $t = 0$ will provide the maximum rearward thrust. Note that the pressure profiles are shown as a function of the shroud velocity, U . This is the pressure profile created by the pumping effect of the impeller shrouds.

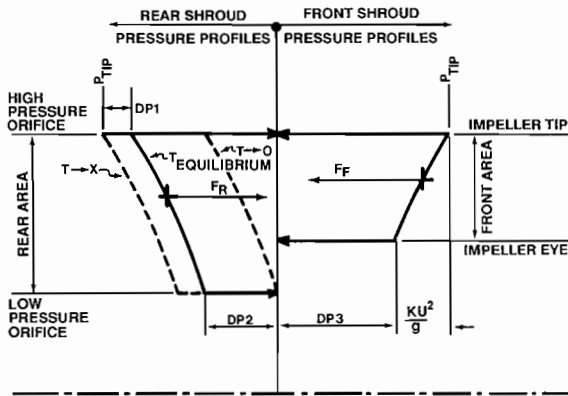

Figure 5. Tandem Axial Thrust Control Pressure Profile Diagram.

An additional illustration of this point is shown on the Figure 6 plot of hydraulic force vs axial gap. The calculated data illustrate the range of the rear shroud force as a function of the gap at the high pressure orifice. This particular plot is for a high speed pump with a fixed low pressure orifice. It is significant to note that the curve becomes steeper as the high pressure orifice closes and flattens somewhat as the orifice opens. It is preferable that the thrust control system be designed for operation within the steep portion of the curve. Here, the thrust control will balance large thrust excursions with minimal axial movements.

The slope of the force curve at any point represents the system stiffness. Typical stiffness is on the order of 500,000 lb/in. As the equilibrium position moves further to the right on Figure 6 (larger high pressure orifice gap), the system becomes softer. At 0.011 in the system stiffness reduces to approximately 90,000 lb/in. It is an important advantage that the highest stiffness zone is approached as the gap decreases. This provides maximum resistance to closure and immediate response to external thrust as clearances are reduced. It is also desirable, in terms of minimizing leakage, to operate the pump at sufficiently close axial clearances. The inherently high stiffness of the system at gaps from 0.002 to 0.009 in aids in meeting minimum leakage objectives.

The thrust control system can be biased to offset large external forces. A smaller rear hub and a larger eye is the

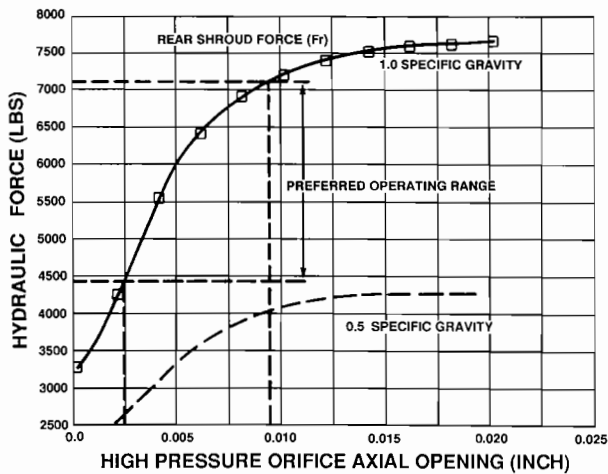

Figure 6. Typical Tandem Axial Thrust Control Force Response Map.

preferred geometry for rear acting external forces. Conversely, increasing the rear hub diameter with a minimum eye diameter will bias the system for forward acting external forces. An example of system biasing is shown in Figure 7. This impeller is used in a high pressure paper mill service. The inlet pressure of the pump varies from 20 to 450 psig. At 450 psig inlet pressure, there exists a significant rear thrust due to inlet pressure acting across the mechanical seal diameter. Increasing the front shroud axial seal diameter decreased the front shroud forces which resulted in an acceptable TATC force balance range and minimum impeller leakage.

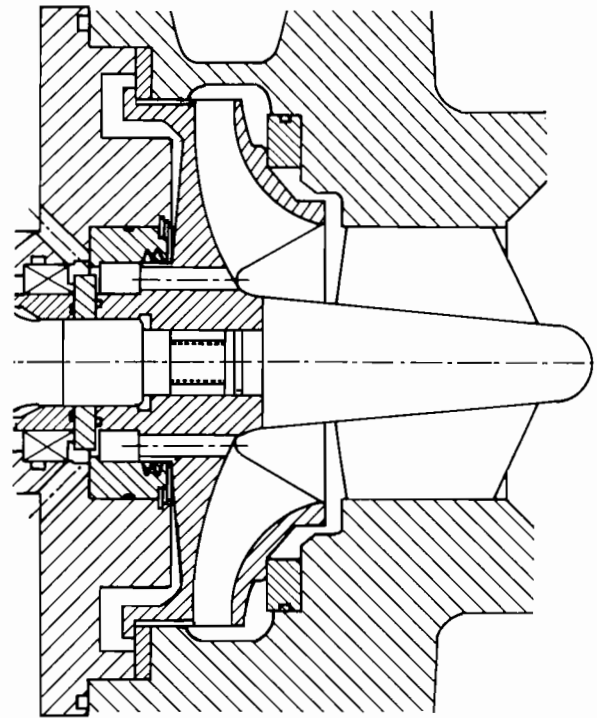

Figure 7. Layout of Tandem Axial Thrust Control with Biased Eye Orifice.

Fluid Properties

Fluid properties most directly impacting the TATC are specific gravity, viscosity, and compressibility. As previously mentioned, the maximum force range of the thrust balance system is established by the pressure capability of the impeller, which is directly proportional to the specific gravity of the pumped fluid. Therefore, the force range of the system is directly proportional to the specific gravity. The force response curve in Figure 6 illustrates the relationship to specific gravity. A lighter gravity fluid will yield a reduced restoring force range and a lower system stiffness. A restoring force curve is shown in Figure 6 (dashed lines) for a 0.5 specific gravity fluid. This reduction in restoring force will not effect the ability of the impeller to balance itself, as the magnitude of the opposing impeller forces are similarly reduced.

The effect of viscosity is to alter the pump performance curve and the flow characteristics of the TATC orifices. The reduction in impeller pressure rise can be estimated by the commonly used correction procedure provided by the Hydraulic Institute. Reduced pressure rise results in a reduction in impeller forces and reduced TATC restoring force. Since the flow coefficient of an orifice is dependent upon Reynolds number, and Reynolds

number is inversely proportional to viscosity, higher viscosity will generally increase orifice flow coefficients resulting in higher leakage for a given gap.

Fluid compressibility and system compliance can affect the response of the TATC. Early development of a similar thrust balance system for a space program turbopump experienced an instability associated with the axial resonance of the thrust balance system. Resonant frequencies are dependent upon the system stiffness and the fluid volume trapped between the orifices. It was found that reduction of the fluid volume in the rear shroud cavity is necessary to raise the natural frequency well above the excitation frequencies. Based upon the space program experience, minimum clearances are used between the impeller shrouds and casing. As a result, industrial experience has shown that the TATC is not subject to axial instability. The resonant frequencies of the TATC are typically well above operating excitation frequencies, such as the impeller blade pass frequency.

Off Design Performance

It is essential that the thrust balance system provide stable operation over the full operating range of the pump. To fulfill this requirement, sufficient static pressure must be available to balance the residual impeller thrust as well as any externally imposed thrust. The pressure source that supplies the thrust system is the static pressure at the tip of the impeller. Although the overall head will drop as the pump approaches runout flow, the static head of the impeller will maintain a much higher relative level. This typical relationship of impeller tip static pressure and pump discharge pressure as a function of flowrate is illustrated on Figure 8. The sustained tip static pressure level enables the TATC system to support external thrust loads over a very wide range of flowrates.

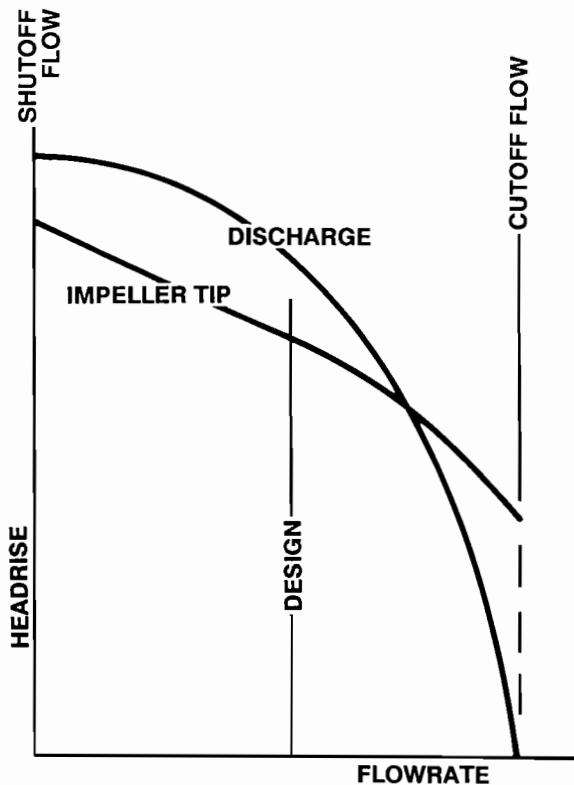

Figure 8. Typical Pump and Impeller Head Rise Characteristics.

Seals and Bearings

The process seal of the pump illustrated in Figure 2 is located downstream of the low pressure orifice. This location allows the process seal to operate near pump inlet pressure or inducer discharge pressure. It is also beneficial that the seal is isolated by the balance piston from impeller blade pass pressure disturbances while maintaining a low seal operating pressure. Impeller balance holes are generously sized to minimize any pressure fluctuations as the balance piston orifice gaps vary to balance thrust. These conditions will result in maximum seal reliability.

Although the TATC provides an active thrust balance over a wide range of conditions, thrust bearings are generally retained in the pump in order to prevent excessive rotor rubs during major upset conditions. The thrust bearings on Figure 9 are shown as faces E and F. In normal operation both bearings are unloaded. This is a result of a liberal axial clearance at the thrust bearing compared to the small axial excursion of the thrust balancing system. At startup, however, inlet pressure acting across the process seal diameter may load the front thrust bearing (E) in an integral gear drive configuration. This condition requires that the axial position of the thrust bearing be such that contact with the thrust runner will occur prior to maximum compression of the mechanical seal. The rear thrust bearing (F) is not used within the desired operating range of the thrust control system.

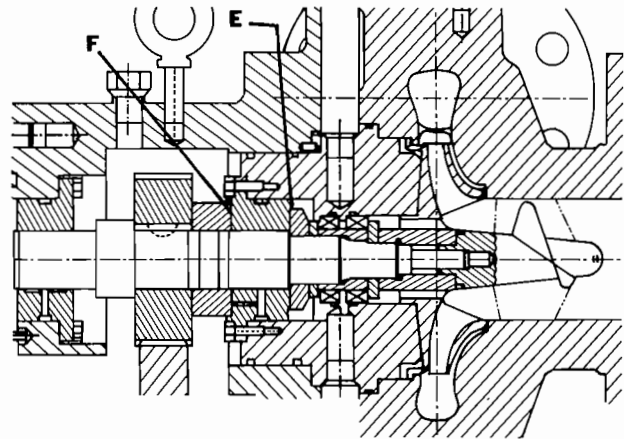

Figure 9. General Arrangement of the High Speed Test Pump Showing Thrust Bearing Faces.

Erosion, Wear, and Leakage Losses

The TATC system reduces the consequences of erosion and wear. Erosion in a typical impeller wear ring with radial clearances results in an increased amount of leakage within the pump stage. In order to slow the process of radial wear ring erosion, the pump manufacturer may provide hardened wear rings and install them at the minimum allowable clearance to achieve maximum hydraulic performance. In the event of a rub at the wear ring, the resulting friction and heat may cause fusion of the impeller and the housing ring resulting in pump seizure. If the axial mating surfaces of the TATC high pressure orifice experience any wear, the impeller will simply change axial position to maintain the same axial clearance. In other words, the clearance and leakage in a TATC system are essentially unaffected by wear.

ANALYTICAL MODELLING

Analytical models of the TATC have been developed for design and analysis of the system based upon pressure profiles

for a forced vortex. The average fluid velocity between a stationary wall and a smooth, rotating disk is approximately one-half wheel speed, $U/2$. This $U/2$ relationship is affected by surface roughness and radial in-flow. The following is a summary of equations which may be used to calculate the force on a rotating disk:

$$\frac{d(P)}{dr} = \frac{-(\rho) V_{\theta}^2}{gr} \quad (1)$$

$$V_{\theta} = KU \quad (2)$$

Where:

- P = local static pressure
- V_{θ} = tangential fluid velocity
- g = acceleration of gravity
- r = local radius
- K = vortex velocity
- U = shroud velocity
- ρ = liquid density

To obtain the pressure gradient between r and r_2 as a function of radius, the vortex pressure gradient integration yields:

$$P = P_2 - \frac{(\rho) U_2^2 K^2 (r_2^2 - r^2)}{g 2r_2^2} \quad (3)$$

To calculate the total force over an annular disk:

$$dF = P (2\pi r) dr \quad (4)$$

The final integration of force yields:

$$F = \pi P_2 (r_2^2 - r^2) - \frac{\pi(\rho) U_2^2 K^2 (r_2^2 - r^2)^2}{4g r_2^2} \quad (5)$$

The pressure drop through the low and high pressure orifices establish the magnitude of the pressure at either the inner or outer diameter of the forced vortex. An appropriate orifice flow coefficient is assigned to the high pressure and low pressure orifices. The impeller balance holes are similarly modeled as an orifice. Pumps which utilize an inducer must account for the inducer head rise effect upon the pressure downstream of the balance holes.

DEVELOPMENT TESTING

A development test program was conducted to study the mechanical and hydraulic performance of the TATC. The test program was set up to collect the following information:

- Rotor axial position throughout the operating range of the pump
- Pump performance data as a function of rear shroud leakage
- Rear shroud leakage data as a function of axial position
- Axial force range of the thrust control system
- Dynamic response of the system under various severe operating conditions

- Pump tolerance to induced rubbing at the axial sealing faces.

Controlled axial position testing was conducted with the balance holes plugged, and the rear shroud leakage flow routed through an external line, through a flowmeter and returned to the pump inlet. A valve was installed in this leakage line to simulate various pressure drop conditions at the low pressure orifice, thereby controlling the axial position. Axial position measurements were made using an eddy current probe at the end of the high speed shaft.

The high speed pump used for a portion of the testing is shown in Figure 9. The pump geometry and the hydraulic design parameters are as follows:

Impeller Geometry

- D1 = 3.12 inch (eye dia.)
- D2 = 6.25 inch (tip dia.)
- C = 2.27 inch (low pressure orifice dia.)

Hydraulic Design Parameters

- Speed = 9300 rpm
- Flow = 350 gpm
- Head = 800 ft
- Power = 120 hp

Fixed low pressure orifice radial clearance = 0.021 inch
Balance holes – (5) @ 0.25 inch diameter

Test instrumentation was selected to measure the pump performance parameters in addition to the TATC system parameters.

Pump Performance Instrumentation

- Pump flowrate
- Pump suction pressure
- Pump discharge pressure
- Input torque
- Input speed

TATC Instrumentation

- Seal cavity pressure
- Rotor axial position
- Rear shroud leakage
- Impeller tip static pressure

A photograph of the pump test arrangement and instrumentation is shown in Figure 10.

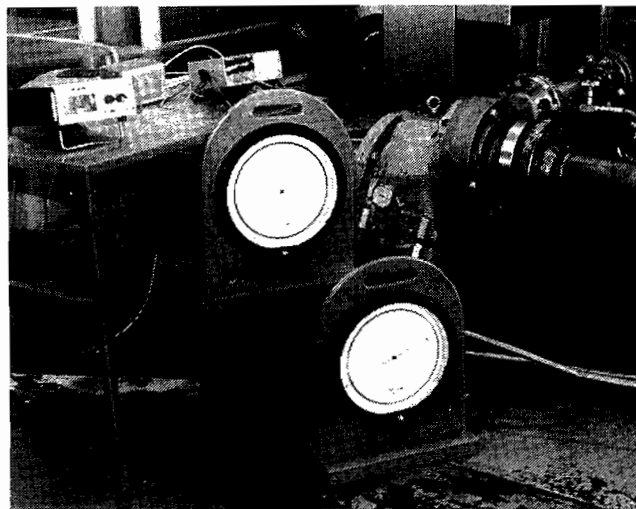

Figure 10. Photograph of the High Speed Test Pump and Instrumentation.

Dynamic response testing was also performed. This testing recorded the axial position of the shaft assembly under various operating conditions. A light beam oscillograph was used to simultaneously record these parameters:

- Pump inlet pressure
- Impeller tip static pressure
- Seal cavity pressure
- Rotor axial position
- Pump speed

The oscillograph receives voltage signals from the pressure, speed, and axial position transducers. The voltage levels are adjusted to set the initial position of a light beam on photosensitive paper. The paper rolls past the light beam at a prescribed feed rate. The oscillograph charts were used to record the system dynamics.

A canned motor pump (CMP) was equipped with similar instrumentation as the high speed pump in order to measure the axial force balance range of the thrust control system. The test pump is shown in Figure 11. A special testing apparatus was used to apply an external axial force to the rotor. An auxiliary disc was mounted on a rotor shaft extension, and differential pressure applied to the disc was used to impart an axial force upon the rotor. A differential pressure gage recorded the pressures, and force was calculated based upon the disc area. The parameters recorded on the canned motor pump oscillograph were:

- Auxiliary disc differential pressure
- Axial position
- Pump inlet pressure
- Impeller tip static pressure
- Impeller rear shroud pressure

The canned motor pump geometry and hydraulic design parameters were as follows:

<i>Impeller Geometry</i>	<i>Hydraulic Design Parameters</i>
D1 = 2.56 in	Speed = 3550 rpm
D2 = 11.0 in	Flow = 180 gpm
C = 3.375 in	Head = 625 ft
Axial Float = 0.026 in	Power = 60 hp
Balance holes - (8) @ 0.25 in diameter	

This testing not only illustrated the dynamic response of the double acting design in a canned motor pump but also the effect of various fluid properties on the thrust balance system. Following is a table of the fluid properties used in the CMP test program:

<i>Fluid</i>	<i>Temperature</i>	<i>Viscosity (Centipoise)</i>	<i>Specific Gravity</i>
Water	115°F	0.6	0.99
Oil	180°F	8.5	0.84

(Oil type - ATF)

HIGH SPEED PUMP TEST RESULTS

Performance results of the high speed pump with the rear shroud leakage returned through the balance holes are shown on Figure 12. Note that the high pressure orifice axial gap at the design point is 0.009 in and the change in this gap is 0.003 in from minimum to maximum flow. A running gap of 0.009 in at

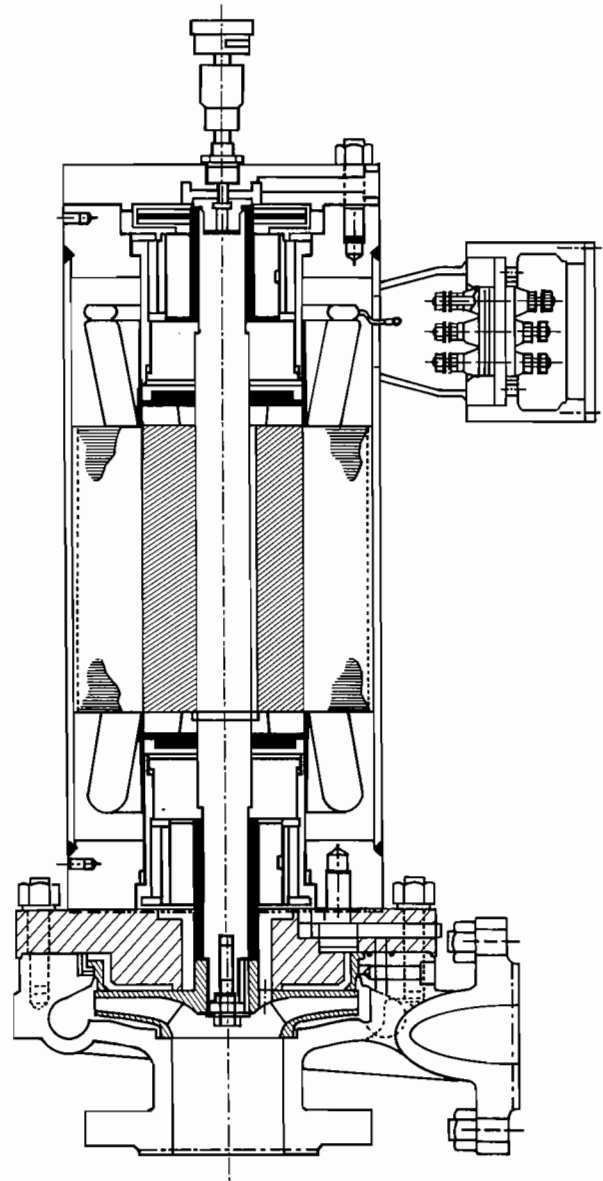

Figure 11. Canned Motor Pump with Tandem Axial Thrust Control System.

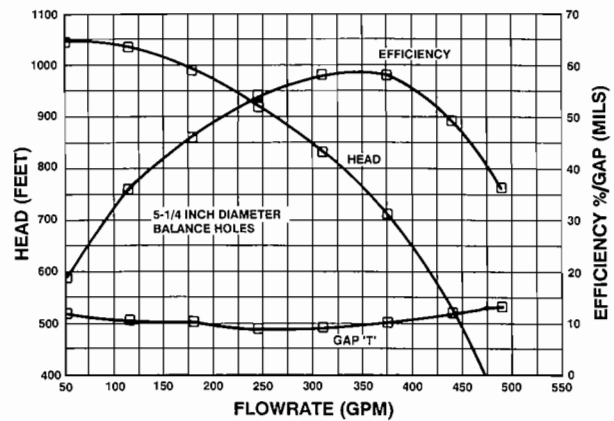

Figure 12. Performance Test Results of the High Speed Test Pump with Impeller Balance Holes.

the axial seals is approximately equal to the equivalent radial clearance required by API 610 for that diameter of seal ring.

Leakage

For comparison purposes, results of the pump test with the controlled rear shroud leakage are shown on Figure 13. The performance gain due to reducing the internal leakage is evident. The performance data was collected with the impeller operating at the minimum clearance end of the "preferred operating range," as shown on Figure 6. This data is compared to the expected performance of an impeller with conventional wear rings at API 610 radial clearances of 0.009 in. The efficiency gains and the head curve shift are clearly due to decreased internal leakage of the TATC.

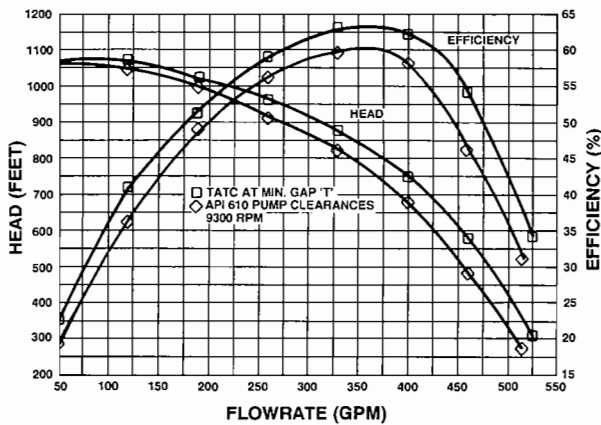

Figure 13. High Speed Pump Performance Data as Tested with Controlled External Recirculation from Integral Balance Piston.

The rear shroud leakage data with the pump operated at a 0.0025 in gap and a 0.009 in gap is shown on Figure 14. This figure also shows the calculated leakage at the impeller eye. Note that at 0.009 in operating gap, the front shroud leakage is greater than the rear shroud leakage. Front and rear leakages occurring at the 0.0025 in clearance test, however, are approximately equal. This is due to the additional throttling at the impeller hub annulus which presents a measurable flow resistance at the higher leakage rates.

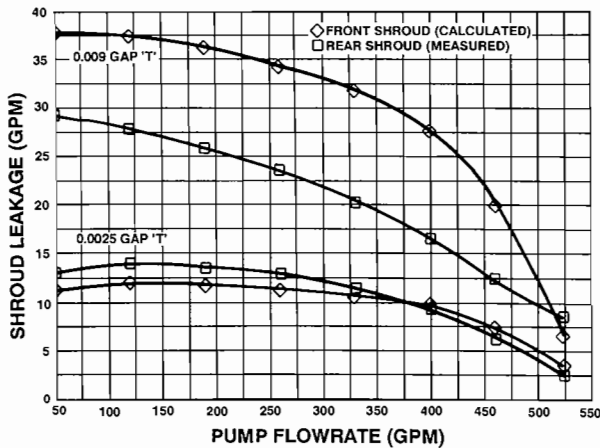

Figure 14. Impeller Leakage Data.

Dynamic Response

The characteristics of the TATC system are best described through an explanation of each dynamic response oscillograph chart. The pump parameters are labeled on the left side of each chart. The scale of the axial position trace is 0.001 in per small division. Time segments are marked on the horizontal axis, referred to as TS1 and TS2. The operating position reference is the axial gap at the high pressure orifice. Nomenclature for the charts is given on Table 1.

Table 1. Nomenclature for Dynamic Response Charts.

T	High pressure orifice axial position
P1	Inlet pressure
P2ST	Impeller tip static pressure
P3	Rear shroud cavity pressure
PSC	Seal cavity pressure
N	Shaft speed
F	External thrust

Startup at 70 psi inlet (Figure 15)

Inlet pressure has forced the rotor to the open position prior to startup. The thrust bearing supports the axial load due to this inlet pressure. The motor is started and accelerates the pump to 9230 rpm. Note that the axial position of the rotor begins to shift at 0.1 sec after start of the motor. The position changes are smooth and act directly with changes in speed and impeller pressure rise. The steady state operating gap is 0.007 in open. This is achieved with no measurable overshoot or time lag with respect to speed, and would indicate that the system is well damped.

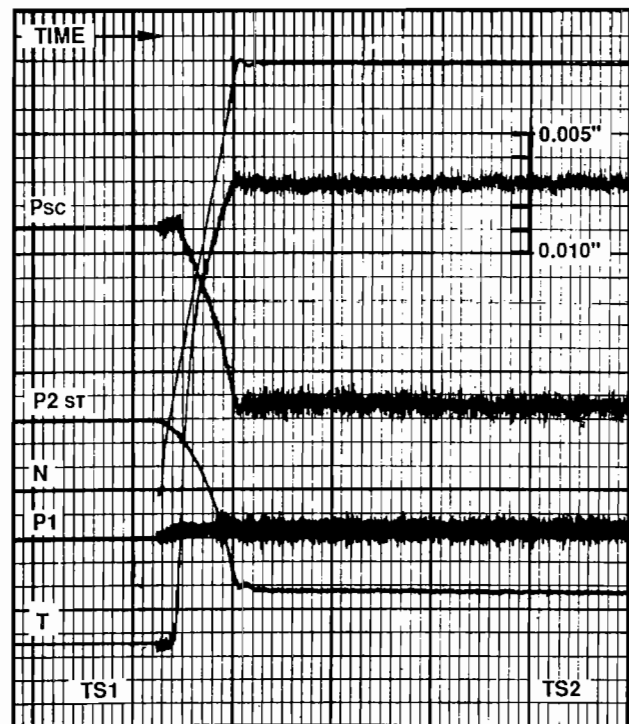

Figure 15. High Speed Pump Response during Startup at 70 PSI Inlet Pressure.

Pump Conditions

Time Segment	TS1	TS2
P1 (psig)	70	70
Psc (psig)	70	132
P2st (psig)	70	310
Position (in)	0.026	0.007
Pump Flowrate (gpm)	0	350
Pump Speed (rpm)	0	9230

Shutdown (Figure 16)

This chart shows the deceleration of the pump after motor shutdown. The seal cavity pressure and impeller tip static pressure behave similarly to the response at startup. That is, the pressure directly follows the affinity laws. The axial position, however, stays constant at 0.0065 in open gap. This is due to the zero psig pump inlet pressure in this example. If the inlet pressure were higher, the position would open slowly as the inlet pressure overcomes the decreasing balancing forces on the decelerating impeller. The 98 psig at the seal cavity is the result of inducer pressure rise and the pressure drop through the impeller balance holes. It is significant that there is no transient reaction of the thrust balance system due to the rapid decrease in speed.

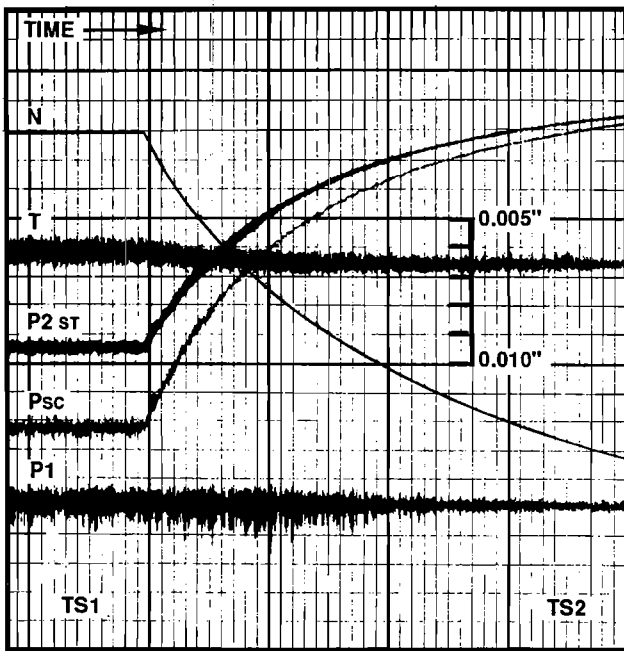

Figure 16. High Speed Pump Response during Shutdown from Design Flow.

Pump Conditions

Time Segment	TS1	TS2
P1 (psig)	0	0
Psc (psig)	98.4	0
P2st (psig)	315	0
Position (in)	0.0065	0.065
Pump Flowrate (gpm)	165 gpm	0 gpm
Pump Speed (rpm)	9230	0

Flowrate Increase to End of Curve (Figure 17)

The system response as the flowrate is increased beyond design flow is shown here as well as the effect of the inducer head/capacity curve. This is a particularly good illustration of the benefit of using impeller tip static pressure as the balance system supply pressure. First, note that impeller static pressure changes from 310 psig at 350 gpm to 235 psig at 530 gpm, a 75 psi drop. The pump head capacity curve (Figure 9) shows that the total head drop at the same flowrate change is 550 ft or a 238 psi drop. This is due to the volute friction losses in the pump at high flowrates. The relatively high impeller tip static pressure enables the thrust control system to balance external axial forces at high flowrates. The drop in the static pressure, however, proportionately decreases the capacity of the system to balance external thrust loads.

The second observation is that the axial gap at the high pressure orifice opens with increased flowrate. At the design flowrate of 350 gpm, the axial position is steady at 0.007 in open. As the flowrate is increased to runout, the gap at the high pressure orifice increases to 0.0135 in. Study of the data indicates that the seal cavity pressure is also changing. The seal cavity pressure trace shows that the pressure has dropped from 132 psig to 84 psig. This is due to the reduction in inducer head at the runout flowrate. As a result, increased flow is required through the low pressure orifice to maintain the necessary

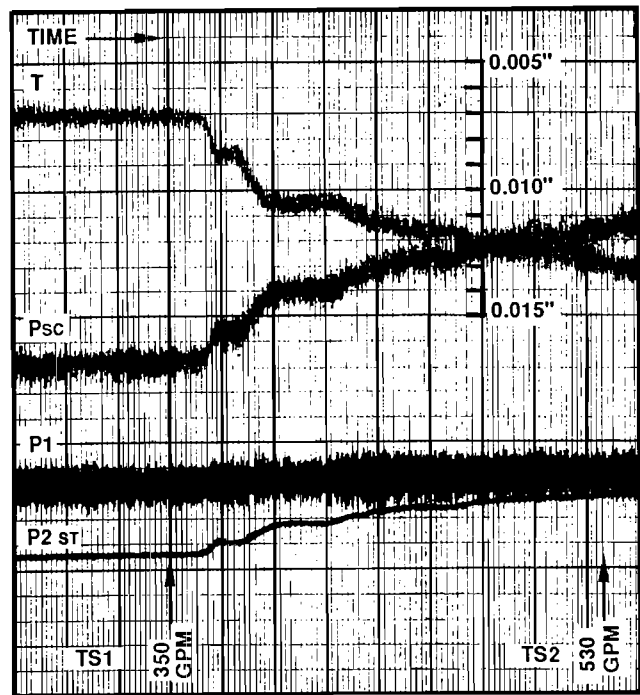

Figure 17. High Speed Pump Response during Flowrate Increase to End of Curve (Cutoff).

Pump Conditions

Time Segment	TS1	TS2
P1 (psig)	70	70
Psc (psig)	132	84
P2st (psig)	310	235
Position (in)	0.007	0.0135
Pump Flowrate (gpm)	350	530

pressure in the rear shroud cavity. The high pressure orifice opens to satisfy this requirement.

Inadequate NPSH (Figure 18)

One may expect that a pump occasionally may be subject to operation under conditions of inadequate net positive suction head (NPSH). This chart shows the results during deep cavitation. As the pump suction pressure is decreased, the axial position sees a transient correction of less than 0.001 in. The operating gap at the high pressure orifice is nominally 0.007 in open. The chart shows quite stable operation of the system in cavitated conditions. If large external forces are present, however, severe cavitation can result in rubbing of the high pressure orifice if sufficient impeller pressure rise is not available to generate the necessary restoring forces.

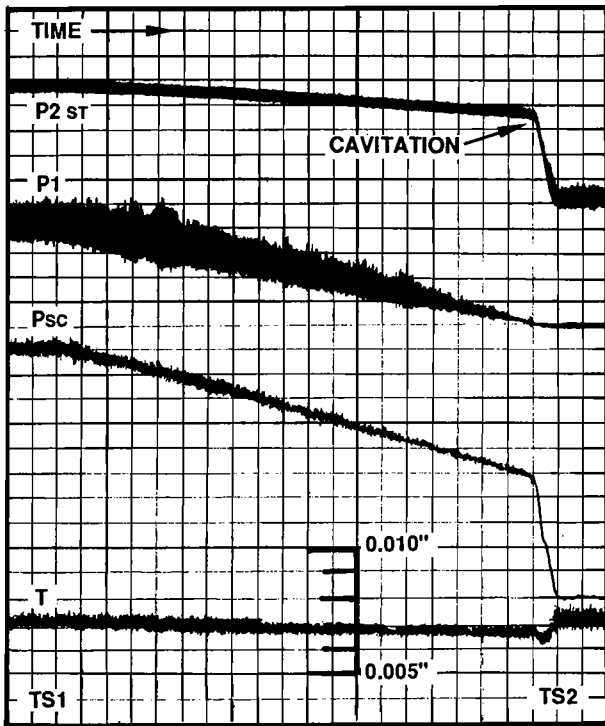

Figure 18. High Speed Pump Response during Inadequate NPSH Conditions at Design Flow.

Pump Conditions

Time Segment	TS1	TS2
P1 (psig)	32	Vacuum
Psc (psig)	104	24
P2st (psig)	290	140
Position (in)	0.007	0.007
Pump Flowrate (gpm)	350	350

Note: The pressure transducers used for this trace could not sense a vacuum and as a result the inlet pressure could not be recorded below zero psig.

Cavitation Surge (Figure 19)

By far, the most abusive test of a pump is operation in cavitation surge. Surge occurs below the minimum flowrate of the pump, where large quantities of impeller or inducer recirculation cause a vortex to form in the inlet piping. If the

NPSH is reduced as well, the cyclical collapse of the vortex will result in severe surging. This chart illustrates the pump operating in the surge condition accompanied by cavitation at low flow. The surge frequency is 4.0 Hz, and the magnitude of the inlet pressure spike is 130 psi. The full range of discharge pressure variation is 70 psi. The pressure pulsation of 70 psi in the seal cavity is attenuated somewhat by the impeller balance holes.

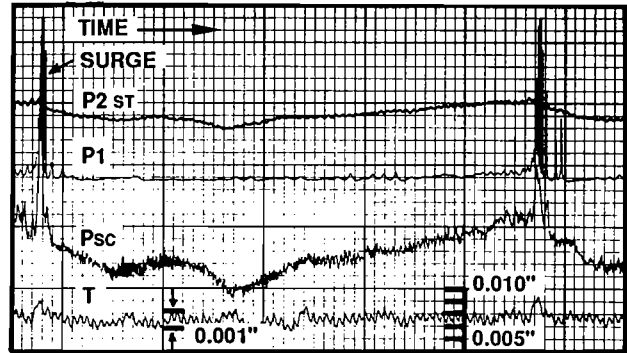

Figure 19. High Speed Pump Response during Cavitation Surge at Low Flow Conditions.

The response of the thrust balance system in cavitation surge is remarkably steady. The maximum excursion of the rotor position occurs at the time of the surge. This excursion is 0.002 in. Note the absence of overshoot or change in frequency of the axial position signature during the pressure spike. This indicates that the axial response is well clear of any system resonant frequencies. The signature of the eddy current probe between surges is very similar to the normal signature at steady state operation shown on Figure 20. This figure contains three rotor axial movement signatures, at 100, 330 and 500 gpm. The chart speed is rapid at 0.05 sec per major division. Analysis of this signal reveals that the frequency is synchronous with running speed. This may be due to runout at the face of the high pressure orifice or due to runout at the probe. Note that the peak-to-peak amplitude of the signature at design flow is approximately 0.0005 in. The amplitude at minimum and maximum flow is less than 0.001 in.

Note the similarity of the surge signature to the minimum flowrate signature. The operating gap at the cavitation surge condition is 0.0075 in, which is consistent with the normal

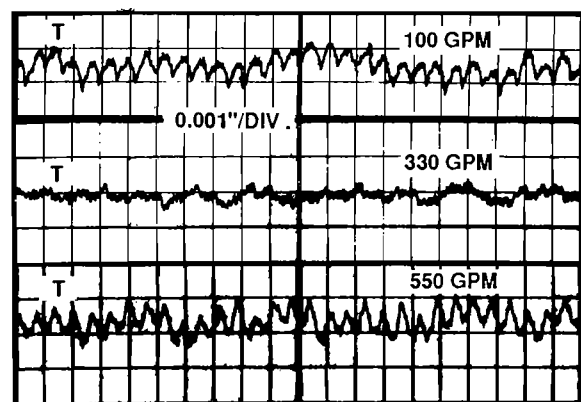

Figure 20. High Speed Pump Axial Position Signatures at Various Flowrates.

operating gap. The steady positional control is attributed to the attenuation properties of the high and low pressure orifices. The rear shroud cavity pressure is relatively quiet.

Wear Characteristics

Although the TATC system normally operates without any rubbing at the variable orifices, there may be process upset conditions that result in intermittent contact with the housing. Intentional rubbing tests have shown that the axial mating surfaces may rub without seizing. Unlike radial wear rings, the thermal growth in the axial wear ring design is not restrained. Testing where an external thrust has overcome the TATC balance capability has shown that continual rubbing at the wear faces will score the material, but not cause seizure. Very severe rubbing results in the transfer of material from the stationary face to the rotating element. This was seen with 316 stainless steel running against 316 stainless steel. The selection of hardened materials will minimize any galling tendencies.

The effect of erosion or wear at the low pressure orifice is minimal as this orifice is the third in a series of four pressure reductions. These pressure reductions are:

- High pressure orifice
- Disk pumping
- Low pressure orifice
- Impeller balance holes

The fixed low pressure orifice used in the development test program had a 0.021 in radial clearance at a 2.27 in diameter. This is 3.8 times the minimum clearance allowed by API. A rub at this location is very unlikely. If this radial clearance increases due to erosion, for example, the high pressure orifice will tend to open rather than close. This is the desired mode, as the system will stabilize at a safe operating condition.

CANNED MOTOR PUMP TEST RESULTS

The response characteristics of the canned motor pump (CMP) have proven to be very similar to that of the high speed pump. The rotor responds instantaneously to external thrust and shows no tendency to overshoot or oscillate axially. The chart records included in this section show the response of the CMP rotor to an external thrust. The signal labeled "F" is the differential pressure applied to an actuator disk.

TATC Force Response

The response to rear external thrust when operated on water is shown in Figure 21, and in Figure 22, when operated on oil. Results are summarized on Figure 23, showing the measured axial force plotted against the operating position of the rotor. The slope of these curves is the system stiffness. As the data show in the normal operating range of the TATC, the system stiffness is directly related to specific gravity. At large operating gaps, however, the response of the oil test was not as expected. The oil data show an almost constant stiffness characteristic at the larger operating gap.

The response of the system is illustrated in Figures 24 and 25 to a rapid pulse of external force when operated on oil and water, respectively. It is shown that there is virtually no difference in the rate of response when operated in water or oil. The stability of the system appears to be independent of viscosity within the range of these tests.

Additional Observations

Operation of the canned motor pump at off-design conditions is very similar to the operation of the high speed pump. The major difference is that the canned motor pump is subject to a steady external thrust due to flow across the motor rotor. The

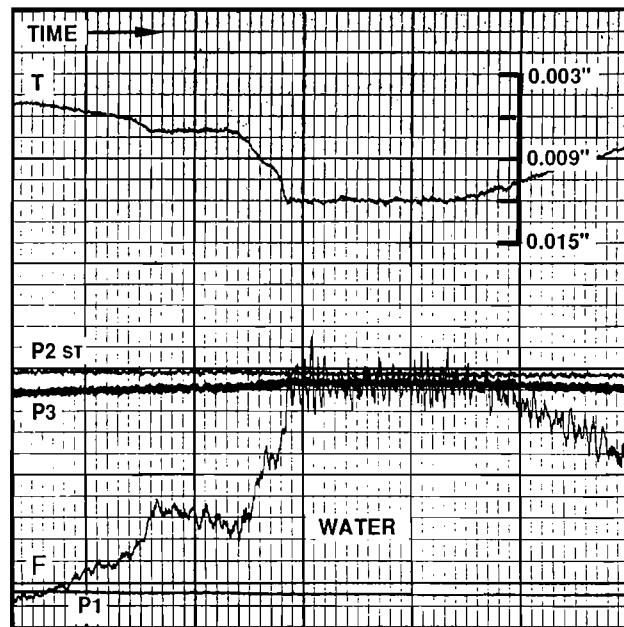

Figure 21. CMP Rotor Response to Rear External Thrust (Water).

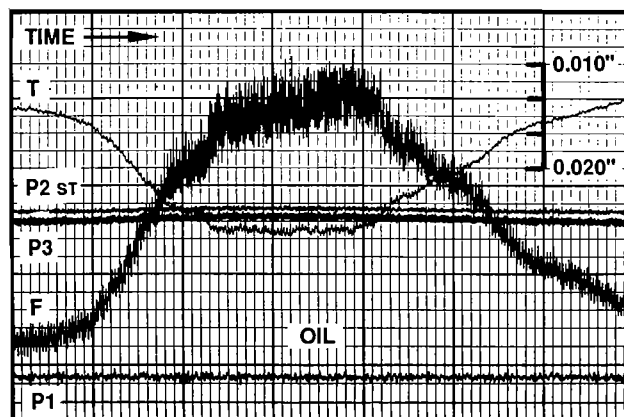

Figure 22. CMP Rotor Response to Rear External Thrust (Oil).

flow across the rotor acts to cool the motor and lubricate the bearings but also acts to create thrust. This thrust will effect the operating position of the TATC and must be accounted for during design. The available restoring force capability must allow for system upset conditions and normal variances in motor thrust.

Testing has shown that the canned motor pump can operate under severely reduced pressure conditions prior to the loss of thrust control. Under heavily cavitated conditions, the total head of the pump was reduced in excess of 50 percent prior to loss of thrust control. It is important to note, however, that the tolerable level of head reduction is related to the available impeller pressure rise, external thrust, and pump geometry. Good analytical modelling tools can help a designer create a TATC system that will span a wide range of external thrusts and system upset conditions.

FIELD EXPERIENCE

Field experience to date includes both high speed units and canned motor pumps. A high speed pump with tandem axial

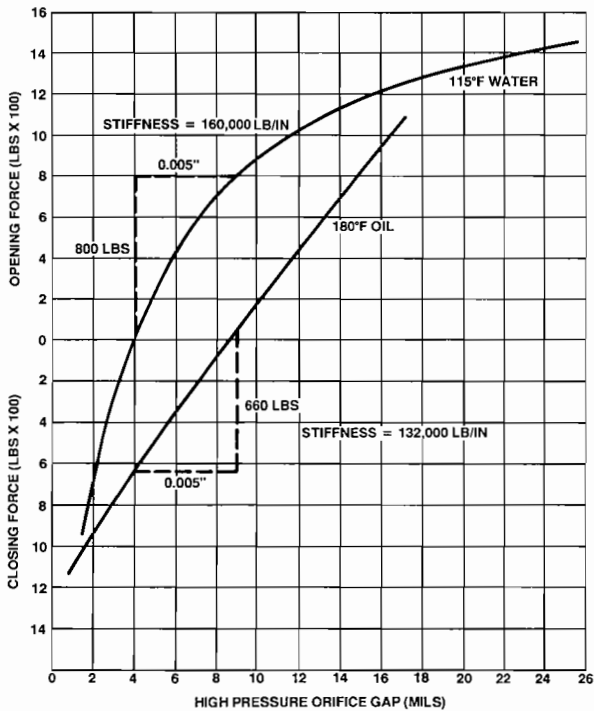

Figure 23. Measured Restoring Force of Tandem Axial Thrust Control Device in a Canned Motor Pump as a Function of the Rotor Axial Position.

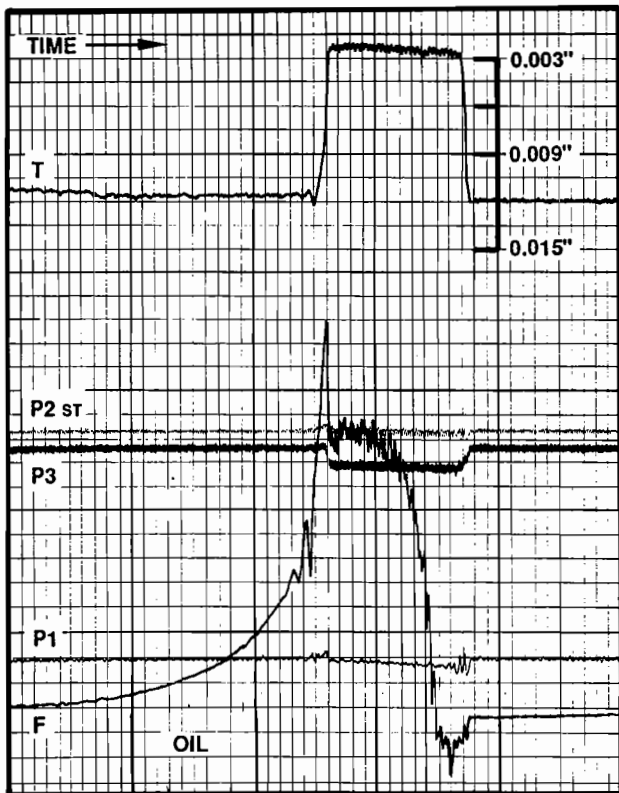

Figure 24. Response of the CMP Rotor in Oil with a Rapid Application of an External Thrust.

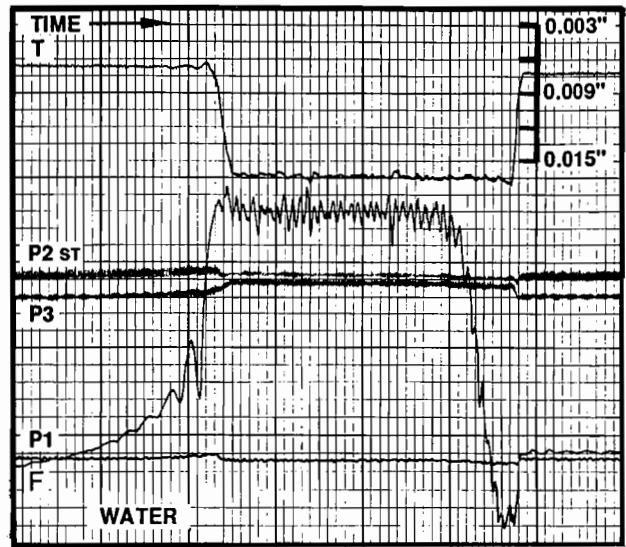

Figure 25. Response of the CMP Rotor in Water with a Rapid Application of an External Force.

thrust control has been in operation for over one year in the pulp and paper industry. The pump is similar to that shown in Figure 9. This is a 270 hp pump operating at 11,500 rpm. Field service records from the authors' company show that although some difficulties were experienced at the startup of this pump, these problems were not related to the thrust control system. After the initial startup problems were resolved, the pump has run trouble free.

Experience in the chemical industry is more extensive, with over three years of operating experience in canned motor pumps with the TATC, a sampling of which is shown on Figure 26. A summary of operating conditions is given on Table 2. The specific gravity of the services varies from 0.8 to 1.6. Most operating viscosities range from 0.2 to 1.5 centipoise, however, some heat transfer fluids are very viscous at startup prior to heating. There has been no evidence of contact on the inactive thrust bearings or appreciable wear of the impeller mating surfaces.

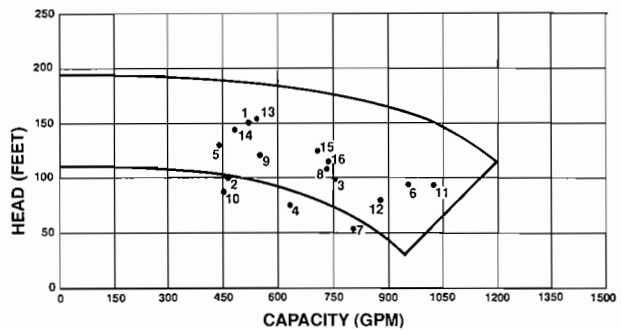

Figure 26. Canned Motor Pump Operating Experience with Tandem Axial Thrust Control System.

MAINTENANCE

Routine maintenance of a pump with the TATC system does not require any special considerations. Normal operation will result in very little erosion of the balance piston orifices as indicated by extensive field experience in many different appli-

Table 2. Operating Conditions for Canned Motor Pumps with the Tandem Axial Thrust Control System.

Graph No.*	Head (FT)	Flow (GPM)	Motor (HP)	No. of Units	Service
1	153	515	40	2	Dowtherm
2	100	460	30	1	Dowtherm
3	100	750	40	2	Rinse Water
4	77	660	40	2	Hydantoin
5	131	418	50	2	Methanol
6	94	1000	50	1	Dowtherm A
7	55	850	20	1	Dowtherm LF
8	110	725	40	5	Therminol 66
9	151	520	50	2	Mobiltherm 603
10	88	450	50	2	Phos.; O.D.B., HCL
11	94	1000	60	4	Phosgene
12	80	860	50	2	Phosgene
13	156	520	40	2	Polyalphaolefin
14	144	485	40	2	Polyalphaolefin
15	125	700	40	2	Dowtherm A
16	115	750	60	3	TiCl4

*Refers to symbols shown on Figure 26

cations. In the event that a severe rub is experienced due to an excessive external thrust or an extended run dry situation, allowable wear can be determined by comparing shaft end play with and without the pump housing installed. As long as the balance piston end play with the housing installed is less than the shaft end play between thrust bearing faces, wear can be considered to be normal. If the balance piston end play is more than the bearing end play it will be necessary to restore the impeller and housing to their original dimensions, particularly the axial dimension between the high pressure orifice and the impeller eye orifice. If the impeller or housing surfaces have been remachined, it will be necessary to verify that there is no

more than 0.002 to 0.004 in runout or waviness at the high pressure orifice axial faces. If these surfaces are not accurately machined, rubbing can occur under high external load conditions.

Reassembly of a pump with a TATC system requires no particular care other than to verify the impeller and shaft end play. Bearing end play can normally be established without shimming since it is generally much larger than the normal excursion of the balance piston. Shimming of the balance piston is also not necessary because the end play is established by the machined dimensions of the impeller and housing. A simple check of the relative end play between the thrust bearings and between the impeller and housing will ensure long trouble free operation.

CONCLUSION

A unique impeller thrust control system has been successfully applied to both sealless and high speed gear driven pumps. Testing and operating experience have shown that the tandem axial thrust control system will provide active thrust balance across a wide range of operation, including typical upset conditions. Dynamic response indicates that the system is stable during upset conditions with predictable behavior. Extensive field experience with high speed units and canned motor pumps has demonstrated the necessary reliability. Continued confidence in the benefits of the system has resulted in increased application on new and existing pump product lines.

REFERENCES

1. Furst, R. B., et al., "Liquid Rocket Engine Centrifugal Flow Turbopumps," NASA SP-8109, pp. 55-59 (1973).
2. Furst, R. B., "Space Shuttle Main Engine Turbopump Design and Development," AIAA No. 75-1301, p. 1 (1975).
3. Gravelle, H.E., "A Centrifugal Pump with Hydraulic Thrust Balance and Tandem Seals," U.S. Patent Office, 4867633 (1989).

ACKNOWLEDGEMENTS

The authors would like to thank the management of Sundstrand Fluid Handling for permission to publish this paper. They also extend special recognition to Ed Gravelle who conceived the patentable feature of the tandem axial thrust control system.