

# A REVIEW OF NSS LIMITATIONS—NEW OPPORTUNITIES

by

**Michael Hirschberger**

**Head of Hydrodynamic Department**

**Ruhrpumpen GmbH of Ruhrpumpen Group**

**Witten, Germany**

and

**Ian James**

**Engineering Manager**

**Ruhrpumpen Inc. of Ruhrpumpen Group**

**Tulsa, Oklahoma**



*Michael Hirschberger has been the Head of the Hydrodynamic Department at Ruhrpumpen GmbH, in Witten, Germany, since 1992. He is responsible for the hydraulic design of the standard pump lines, tailor-made pumps, and retrofit projects and supports sales/applications, service, and customers in hydraulic issues.*

*Mr. Hirschberger received a Dipl.-Ing. degree (Mechanical Engineering, 1984)*

*from Aachen University of Technology, Germany, and joined Ruhrpumpen as a hydraulic engineer in the same year. For many years, he has been a member of the R&D group of German pump manufacturers within the German VDMA. He has published numerous papers and articles, and sits on several committees.*



*Ian James is the Engineering Manager of Ruhrpumpen Inc., in Tulsa, Oklahoma. He provides engineering support and guidance in the areas of sales/applications, design, testing, marketing, training, after-sales, and customer support. He has developed in-house design and stress analysis guides for major pump components and has coauthored several technical papers, including the “Variable Speed Pumping*

*Guide” for both the BPMA and Europump/HI. For more than 40 years, he has worked in the process, offshore, chemical, pharmaceutical, and heat transfer sectors at HMD Sealless Pumps, Ingersoll-Dresser Pumps, and Bingham-David Brown Pumps.*

*Mr. James is a member of the ASME B73 Committee, API 610 Joint Working Group, API 685 Committee, and was a member of the BPMA Technical Committee, which produced the ISO Sealless Pump Specification EN-ISO-15783.*

## ABSTRACT

Specifications of some pump users limit the suction specific speed (N<sub>ss</sub>) with the objective of selecting more reliable centrifugal pumps. This limitation is based on a statistical evaluation of pump failures published by Hallam (1982) that seemed to show a relationship between the value of N<sub>ss</sub> and the probability of failure. It was stated that intensive suction recirculation had caused the failures of the pumps with high suction specific speed, but the root

causes of these failures were not examined at that time. Investigations presented by Bunjes and op de Woerd (1984), Breugelmanns and Sen (1987), and Guelich and Egger (1992) have since shown that suction recirculation depends on a variety of parameters. Experimental investigations by Stoffel and Jaeger (1996) with high and medium N<sub>ss</sub>-impellers showed that no significant differences of vibrations, shaft deflection, and other dynamic loadings were detected. Therefore the suction specific speed cannot be used as the one and only parameter for the prediction of the reliability of a centrifugal pump. The effect of preventing the use of higher suction specific speed pumps can result in having to use a less efficient and more expensive pump, without seeing any measurable benefits in pump reliability.

## INTRODUCTION

The net positive suction head available (NPSHA) of a system is one of the most important values of an application, as much to limit the installation costs as it is for the selection of pumps. Very often the system characteristics imply low values of NPSHA. The net positive suction head required (NPSHR) of the pump is based on a defined head drop. The most commonly used head drop is 3 percent. Therefore for all operating conditions, a sufficient margin between NPSHA and NPSHR is required to ensure a safe and damage-free operation of the pump. This margin depends on the individual factors such as pump type, pump power, pump speed, liquid properties, etc. There are two ways of ensuring an adequate NPSH margin:

- Increasing the NPSHA by means of higher elevation and/or higher pressure of suction vessels, lower elevation of the pumps, and reduced friction losses of the suction piping (i.e., larger piping diameter). Even subcooling the pumped liquid can be used to increase the NPSHA. Although this is rare and expensive, it is possible.
- Selecting a pump with low NPSHR.

The first option results every time in high additional investment costs for the installation.

At a given flow rate Q and speed N the NPSHR of a pump depends on the type (single-/double-suction), and also on the design of the suction and the vane leading edge. To compare pumps that are designed for different best efficiency points (BEP) and speeds, the suction specific speed can be calculated according to Equation (1).

$$N_{ss} = N \cdot \frac{\sqrt{Q}}{NPSHR^{0.75}} \quad (1)$$

For double suction pumps only half of the BEP-flow has to be used for the Nss calculation, since the Nss is considered per impeller eye.

As well as using rpm for the speed in most cases the American units of US gpm and ft are used for the calculation of the suction specific speed. Using these units, suction specific speed values of over 14,000 for impellers, and over 20,000 for inducers, can be reliably achieved. However, some pump users, consultants, and specifications often recommend limiting the suction specific speed to around 11,000. The motivation for this limitation is the conviction that there is an increased risk of mechanical failures of bearings, mechanical seals, or impellers for pumps with high Nss-values. However, the basis for this assumption relies on a statistical evaluation of pump failures presented in 1982 by Hallam.

His statistical evaluation of these pump failures indicated a trend that the probability of failure increased with higher suction specific speeds above 11,000. Hallam's explanation for this finding was intensive suction recirculation caused by large suction eye diameters.

However several investigations carried out by Bunjes and Op de Woerd (1984), Breugelmanns and Sen (1987), and Guelich and Egger (1992) have since shown that suction recirculation and cavitation damage depends on many design and operation parameters, rather than just being caused by large impeller eyes. Therefore relying only on an Nss-limitation is an oversimplification that cannot guarantee high reliability. Also, application of this Nss limitation often results in more economic and reliable pump selections being excluded from consideration. However, these days, with improved design methods, and a better understanding of the flow by experimental results, reliable pumps with low NPSHR/high Nss can be assured. Meanwhile, innumerable pumps having a Nss > 11,000 are running worldwide with the same safety and reliability as pumps with Nss < 11,000.

#### DISCUSSION OF THE FAILURE STATISTICS BY HALLAM FROM 1982

For a failure analysis, 480 pumps were observed in one refinery from 1976 to 1981. Based on these observations Hallam carried out a statistical evaluation. These statistics indicated a trend that the failure probability increased for a suction specific speed > 11,000. He argued that for pumps with high Nss, which means low NPSHR, a large suction eye diameter was necessary. He also felt that a large suction eye diameter can result in suction recirculation starting at relatively high flow rates. He concluded that excessive suction recirculation would therefore be responsible for cavitation damage and/or high excitation forces causing noise and vibrations, early wear, and all kinds of associated failures, including mechanical shaft seals, bearings, etc.

These failure statistics showed that at that time there was definitely a problem of pump reliability. Unfortunately a definitive and detailed analysis of the root causes was never pursued or identified, and so the real reason for these pump failures was never established.

For reasons of economy and to minimize size, pumps with high Nss/low NPSHR are preferable for refineries in low NPSHA applications. With such installations, careful design of the suction system feeding the pumps is more critical for safe and reliable pump operation. Special care must be taken to avoid turbulence in the suction piping, such as that caused by bends, valves, and strainers located too close to the pump. Experimental and numerical investigations by Roth (2006) have shown that unfavorable suction piping and valve installation have an influence on the performance (head, efficiency) and can provoke cavitation.

Also, too low a liquid level in the suction tank, or a clogged strainer, can very quickly reduce suction pressure below the NPSHR of the pump, thereby causing pump failure. In addition, if antivortex baffles are badly designed, or even missing from the suction tank, then vapor/air can be drawn into the suction vortex resulting in pump problems similar to, and including, cavitation and surging.

Process pumps are mainly used to deliver hydrocarbons, which are not very aggressive with respect to cavitation erosion. Therefore it can be assumed that the observed failures by Hallam (1982) are mainly focused on mechanical problems, rather than those caused by cavitation erosion.

Such mechanical problems could be caused by poor mechanical design and/or an incorrect or oversized pump selection. Modern pumps are very reliable machines with a typical lifetime of around 25 years, and most heavy duty, refinery process pumps will exceed this. The development of a pump line takes time and so it can be assumed that the pumps involved in this statistical evaluation were designed in the 1960s or even earlier. So the root causes of a large number of pump failures observed by Hallam (1982) would probably be related to inadequate design, wrong material selection, low quality, and/or poor pump selection. Typical examples given by Guelich (2004) might be:

- Unfavorable designs that could have resulted in problems and failures—such as overhung pumps with two stages or overhung double-suction impellers—were installed in many plants at that time. In recognition of the problems such designs have caused, the last few editions of API 610 (2004) no longer allow these pumps to be used.
- Application of a single volute instead of a double volute. Modern pump designs use double volute construction, particularly on the larger branch sizes, to avoid the mechanical problems that can occur with the larger single volute designs. These problems cause excessive shaft deflections, bearing loads, and seal leakage. This is especially relevant to low flows, where the radial loads are the highest.
- Insufficient shaft stiffness can be the reason for bending of the shaft and/or high vibration amplitudes, causing failures of the mechanical shaft seals and/or wear of the wear rings. Modern pumps meeting API and customer's latest specifications also have shaft stiffness limits that apply, such as  $L^3/D^4$ , which result in many pumps today being a stiffer design than 30 years ago, and so less prone to vibration and other related problems.
- Excessive casting tolerances leading to high vibrations at one time rotational speed due to hydraulic unbalance.
- Insufficient rotor damping due to unfavorable labyrinth design of bushings and balancing drums.
- Too small gap B between impeller outer diameter (OD) and volute cutwater or diffuser vanes (Figure 1). Too small a gap can cause pressure pulsations and high vibrations at vane passing frequency. In the 1960s and 1970s there was a trend to use smaller radial gaps, in order to achieve the highest possible head. Nowadays API 610 (2004) has defined the minimum allowable gap between the impeller OD and the volute cutwater or diffuser vanes.
- Wrong pump selection.

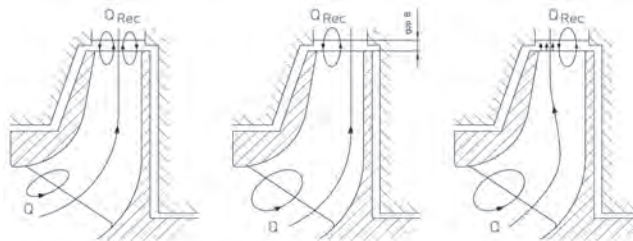

Figure 1. Possible Profiles of Flow Recirculation.

Any pump failure caused by the above listed design insufficiencies could be easily misinterpreted as having been caused by excitation due to low flow suction recirculation. However, "excessive" failures may have only been due to a poor design or a bad pump selection. With a correct design a failure would be avoided and any

suction recirculation present would not have been evident and would not have had any impact on the pumps.

Just as in the case of specific speed ( $N_s$ ), the suction specific speed is an index number. By using  $N_{ss}$  the suction performance of geometrically different pumps can be compared. So by definition  $N_{ss}$  gives no information about impeller inlet recirculation, hydraulic excitation forces, or the potential for cavitation damage. Fraser (1982) did not limit the suction specific speed in general. He presented diagrams showing the onset of suction recirculation depending on  $N_{ss}$  and the hub diameter. Using the hub diameter as an additional parameter at the same time takes the power into account. Due to the high power the intensity of recirculation and turbulence influences are higher. Therefore the minimum continuous flow should be increased for pumps with higher power. Fraser has realized this point by using different lines for different ratios of hub/suction eye diameter. He carried out his investigations at the same time as Hallam, and so it can also be assumed that the pumps he had observed were designed in the 60s. Therefore it is probable that the steepness of the lines of Fraser's diagrams today is not valid anymore, since the design rules of hydraulic components have been improved since then. Also Budris (1993) realized that the suction specific speed cannot be the one and only parameter for pump reliability. For his method he used additional parameters like pump style, impeller inlet tip speed, impeller vane overlap, and fluid specific density.

In 1998 the Hydraulic Institute presented the guideline ANSI/HI 9.6.1 using the suction energy (SE) which is defined by the following Equation (2):

$$SE = De \cdot N \cdot N_{ss} \cdot \rho \quad (2)$$

This guideline recommends NPSH margins with respect to low, high, and very high suction energy levels. A graph gives the range for low and high SE, but not for very high SE. One drawback of that guideline was the gradation between the different suction energy levels. However this guideline has since been withdrawn.

## FLOW RECIRCULATION

Flow recirculation occurs not only at suction eye but is also seen within the flow channel between the impeller vanes up to the volute or diffuser (Figure 1). By 1980 Sen had investigated experimentally the inlet flow of impellers with different designs (e.g., suction eye diameter, meridional contour, vane numbers, vane loading), and further investigations are presented by Guelich and Egger (1992). In order for suction eye recirculation to really appear, two preconditions have to be met:

- A local flow separation has to occur due to deceleration of the relative velocity upstream of the leading edge at the smallest cross section.
- Strong pressure differences transverse to the direction of the main flow have to exist.

One of the above preconditions alone will not induce suction eye recirculation. A combination of these two phenomena is necessary, as Guelich explains in his handbook (2004).

The main design parameters influencing the suction eye recirculation are:

- Ratio of leading edge diameters at hub and shroud.
- Impeller throat area.
- Angle of approaching flow.
- Impeller vane angles.
- Impeller shroud curvature.
- Location of the leading edge in the meridional section and plane view.
- Overlapping of the impeller vanes (solidity).

The incidence angle with regard to the leading edge angle is often considered to be decisive, but in fact only has a secondary influence on the start of suction recirculation.

The velocity and pressure distribution at low flow is complex and 3-dimensional, and influences the suction recirculation. So it is obvious that no simple relationship can describe or predict the start and intensity of suction recirculation. The start of suction recirculation could be calculated by computational fluid dynamics (CFD) with high efforts. However, even then, clear statements regarding recirculation intensity and possible damages cannot be expected from the CFD results. So trusting only one parameter can mislead into a belief that recirculation damage has been avoided, which may not be the case.

Some nondamaging recirculation is present in each centrifugal pump operating below/or above a certain flow and cannot be avoided. Mostly this recirculation is only observed because of problems like higher vibrations, pressure pulsations, cavitation damages, etc. Without one or more of these problems neither pump operators nor maintenance staff would be aware that recirculation is in fact occurring within the pumps. Case studies given by Guelich (2001) had shown that even at suction specific speeds below 11,000 recirculation can still cause cavitation damage. So the start of recirculation itself is of less interest than the onset of damages due to intensive recirculation.

Another point worthy of note is that recirculation at the suction eye increases the head. Due to the blockage of the flow by the recirculation, the flow enters the impeller on a considerable smaller effective diameter. So according to the Euler equation the head is increased. As a result the stability of the curve is improved at low flows. This head increase due to suction recirculation depends on the specific speed: The lower the  $N_s$  the lower the head increase.

## EXPERIMENTAL INVESTIGATIONS OF IMPELLERS WITH MEDIUM AND HIGH SUCTION SPECIFIC SPEED

As already mentioned Hallam's (1982) recommendation to limit the suction specific speed was based on a statistical evaluation. However, this correlation has not been proven by systematic tests applying scientific research methods. Therefore a corresponding research project was carried out by Stoffel and Jaeger (1996) at the Darmstadt University of Technology, Germany. These extensive investigations were made for the Verband Deutscher Maschinen und Anlagenbau - German Engineering Federation (VDMA). The project team was given advice by a working group of experts from several German pump manufacturers.

The aim of that project was to find any differences in the hydraulic excitation of impellers with high and medium suction specific speeds. Three pumps from different manufacturers having different specific speeds from  $N_s = 11$  to 42.5 in metric units (US units: 568 to 2195) were tested in detail. Also each pump design was supplied with alternative impellers, one of a medium suction specific speed design and one of a high suction specific speed design. The impellers were tested within the same casing. The type OH2 (single-stage, single-suction) and the range of operating data of these selected pumps can be taken as representative for a majority of process pump applications. As well as the characteristic curves and NPSH at different cavitation conditions the following dynamic quantities were measured:

- Shaft deflection at locations close to the mechanical shaft sealing
- Pressure pulsations at the suction and discharge
- Vibrations at the bearing house
- Dynamic component of the axial thrust

The head curves and efficiency curves, and so also the best efficiency point, are nearly identical for both impeller designs for



all three pumps. So the basic requirements for all comparisons are fulfilled. Data of pump 1 are given in Table 1. For the medium Nss impeller the calculated onset of suction recirculation according to Fraser (1982) was about 20 percent less than the actual value measured. Contrary to common belief, the onset of the suction recirculation of the medium Nss impeller with smaller suction eye was detected at a higher flow compared to the high Nss impeller. Table 2 shows the calculated onset of the suction recirculation using Fraser's (1982) method for the six impellers. According to these calculations with increasing specific speed the onset of suction recirculation is shifted to lower flow. This is again contrary to the common experience and expectations: Actually with increasing Ns the suction recirculation starts even at higher flow.

Table 1. Data of Test Pump 1.

Pump 1	medium Nss	high Nss
Suction specific speed (min <sup>-1</sup>   -)	190   9814	237   12241
Q <sub>BEP</sub> (m <sup>3</sup> /h   gpm)	42   185	42   185
H <sub>BEP</sub> (m   ft)	113   371	113   371
N (rpm)	3480	3480
Specific speed (min <sup>-1</sup>   -)	11   568	11   568
Suction branch (mm   in)	80   3.15	80   3.15
Discharge branch (mm   in)	40   1.57	40   1.57
Suction eye diameter (mm   in)	76   2.99	82   3.23
Impeller diameter (mm   in)	259   10.2	259   10.2
Vane angle at inlet β <sub>31a</sub> (°)	24.0	17.0
No. of vanes	3	3
Velocity v <sub>ve</sub> at BEP (m/s   ft/s)	2.57   8.43	2.21   7.25
Q <sub>shockless</sub> /Q <sub>BEP</sub>	1.12	0.98
Meas. onset of suc. rec. (m <sup>3</sup> /h   gpm)	47   207	44   194
Calc. onset of suc. rec. (m <sup>3</sup> /h   gpm)	38   167.3	41.5   182.7
Meas. Q <sub>onset suc. rec.</sub> /Q <sub>BEP</sub>	1.12	1.05
Calc. Q <sub>onset suc. rec.</sub> /Q <sub>BEP</sub>	0.905	0.987

Table 2. Calculation of the Suction Recirculation Onset, According to Fraser (1982).

Pump	Nss	Calc. Q <sub>onset suc. rec.</sub> /Q <sub>BEP</sub>	
		Medium Nss imp.	High Nss imp.
1	11	0.905	0.987
2	22	0.603	0.753
3	42.5	0.554	0.627

The NPSH-curves at 1 percent and 3 percent head drop of pump 2 are presented in Figure 2. The dynamic parameters like the deflection of the shaft were measured at the following conditions:

- No cavitation
- Incipient cavitation
- One percent head drop
- Three percent head drop

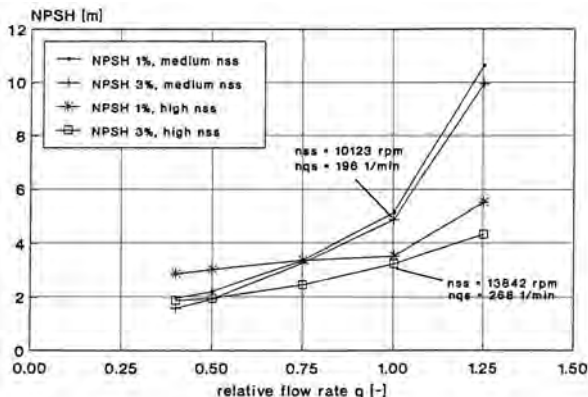

Figure 2. NPSH Versus Relative Flowrate, Pump 2.

Incipient cavitation, when the first bubbles appear, was detected acoustically by a pressure transducer located at the pump inlet. The four measured dynamic quantities can be considered to be indicators for dynamic loadings that can be responsible for failures of:

- Mechanical shaft sealing.
- Shaft.
- Bearings, radial and axial.
- Pump structure (casing, flanges).
- Foundation.
- Pipe connections and piping installation.

For the three test pumps only the impellers were changed from medium to high Nss impellers. All other mechanical and test details were identical for both impellers of the same test pump. Therefore it could be assured that when comparing the test data of the same pump at the same cavitation condition, the only influence comes from the different impeller design. Some examples of the dynamic quantities are shown in Figures 3 to 6.

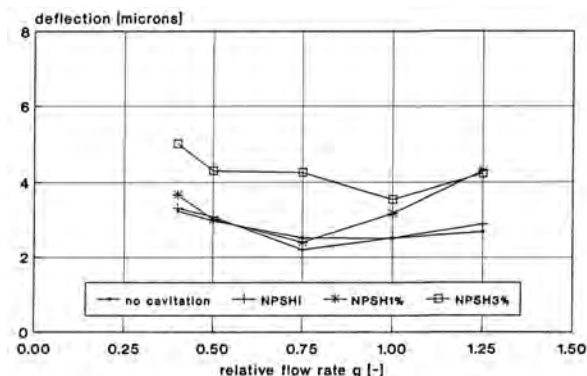

Figure 3. Shaft Deflection Pump 3, Medium Nss Impeller.

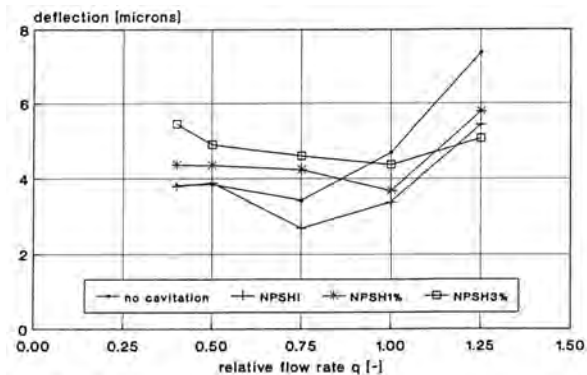

Figure 4. Shaft Deflection Pump 3, High Nss Impeller.

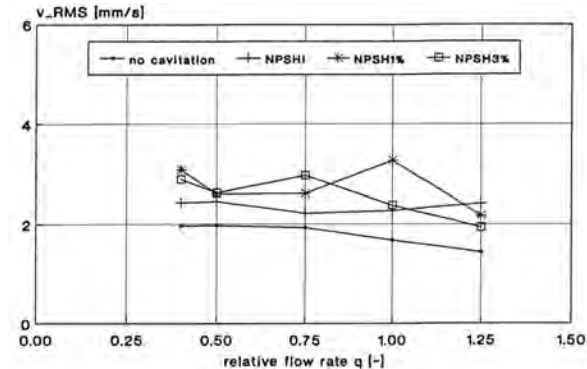

Figure 5: Bearing Housing Vibrations Pump 1, Medium Nss Impeller.

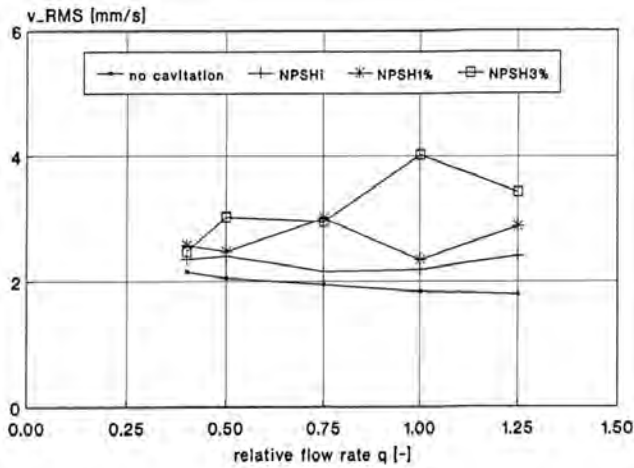

Figure 6: Bearing Housing Vibrations Pump 1, High Nss Impeller.

The main result of these measurements is the fact that in the operating range of 40 percent to 125 percent BEP no significant correlation between the measured vibrations, respectively, dynamic fluctuations and the suction specific speed was found (Table 3). Sometimes amplitudes were slightly higher at high Nss, but there are also cases of higher amplitudes at medium Nss variants (all of them at a relatively low level).

Table 3. Impact of Suction Specific Speed on Dynamic Parameters.

Pump	Nss	Shaft deflection	Pressure pulsations at suction	Pressure pulsations at discharge	Vibrations of the casing	Dyn. axial thrust
		(mil) ( $\mu\text{m}$ )	(% of the actual head)	(% of the actual head)	(in/s) (mm/s)	(lb[force]) (N)
1	medium	0.315-0.906 8-23	0.45-0.83	2.33-3.97	0.055-0.130 1.4-3.3	5.39-12.14 24-54
	high	0.433-0.984 11-25	0.60-1.97	2.77-6.64	0.071-0.157 1.8-4.0	5.40-16.86 24-75
2	medium	1.496-1.732 38-44	0.95-2.43	3.28-8.22	0.035-0.067 0.9-4.0	6.52-28.33 24-75
	high	1.260-1.496 32-38	0.50-2.41	1.70-6.09	0.043-0.075 1.1-1.9	6.74-26.30 30-117
3	medium	0.078-0.197 2-5	0.84-1.44	1.02-2.14	0.106-0.409 2.7-10.4	7.19-17.53 32-78
	high	0.118-0.276 3-7	0.90-1.59	0.88-2.44	0.122-0.346 3.1-8.8	6.29-21.81 28-97

Therefore the assumption that an Nss value > 11,000 is, by itself, responsible for pump failures like broken seals, damaged bearings, etc., is inconclusive and not very likely.

DESIGN FEATURES TO IMPROVE NPSHR

Compared to the 1960s a lot of research and investigations were carried out to understand the effects inside the flow channels of pumps. The design rules of hydraulic components were improved. As often mentioned in older literature the suction eye was increased in the past with the intention to reduce the NPSHR of the pump. Today low NPSHR-values can be achieved with a smaller suction eye diameter compared to the design rules of the 1950s and 1960s by using a proper vane layout. These vane layouts were developed by experiments and numerical methods. With CFD the incident angle and the pressure distribution from the leading to the trailing edges of the impeller vanes can be checked. Also the correct positioning of the vane leading edge is important. Therefore it is nowadays possible to design impellers achieving low NPSHR/high Nss with reasonable suction eye diameters and good reliability. Figure 7 shows test results of two impellers with different vane layouts. The geometry like meridinal contour and location of the leading edge was identical.

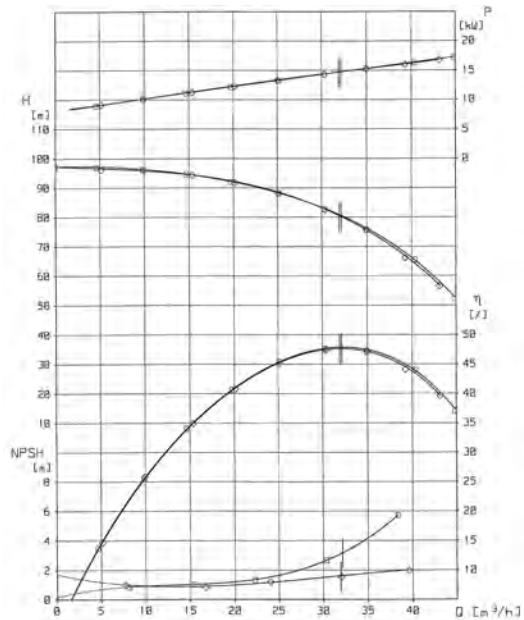

Figure 7. Comparison of Two Different Vane Layouts on NPSH with Identical Meridinal Contour.

Not only the design of the impeller, but also the pressure losses from the suction nozzle to the leading edge of the impeller, have an influence on the NPSHR. The NPSHR is calculated using the pressure at the suction piping, just in front of the pump suction nozzle. Reducing the losses in the pump suction means that the head drop occurs at a lower suction pressure, which is equivalent to a lower NPSHR. In other words Nss becomes higher but the impeller hydraulics remain the same. Figure 8 shows the sectional drawing of a pump designed in late 1950s. The unsymmetrical suction nozzle is not unusual for the pump design at that time. As a result of one side of the nozzle being tapered, a velocity component is induced that is not symmetrical to the impeller rotational axis. The hydraulic design of the impeller vane leading edges were based on the expectation of uniform flow regimes through the suction nozzle. So this nonuniform flow causes additional losses and turbulence, and affects the expected performance. The impeller is fixed by a simple hexagon nut. A sectional drawing of the modern pump is depicted in Figure 9. The symmetrical suction nozzle ensures a uniform flow pattern to the inlet of the impeller. The flow optimized impeller nut causes less flow turbulences with respect to losses compared to a conventional nut. So as a result the NPSHR can be reduced without any change of the impeller. This is not only valid for overhung pumps. Bunjes and op de Woerd (1984) have reduced the NPSHR by approximately 20 percent by improving the design of the suction channel from a double suction pump (Figure 10). Further factors that are influencing the NPSHR are the balancing holes and the wear ring clearance. Figure 11 shows the corresponding NPSHR-curves of a process-pump with low specific speed.

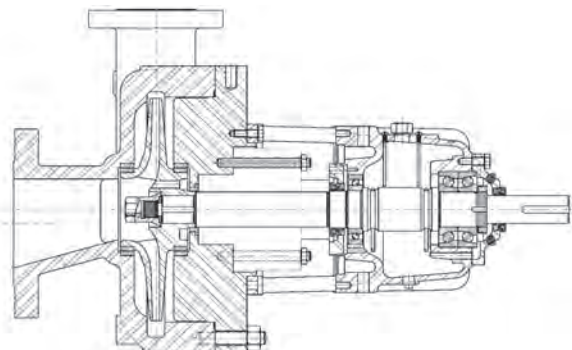

Figure 8. Sectional Drawing of a Pump Designed about 50 Years ago.

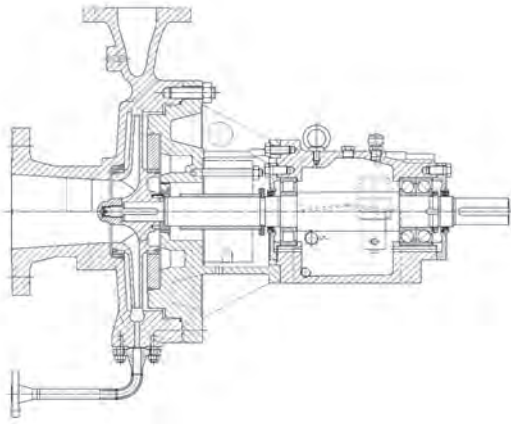

Figure 9. Sectional Drawing of a Modern Pump.

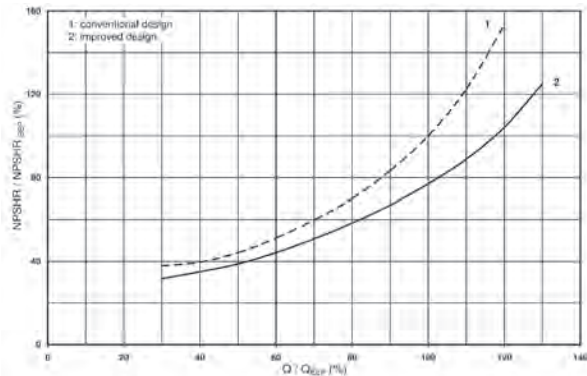

Figure 10. Influence of Suction Chamber of a Double Suction Pump on NPSHR (Same Impeller).

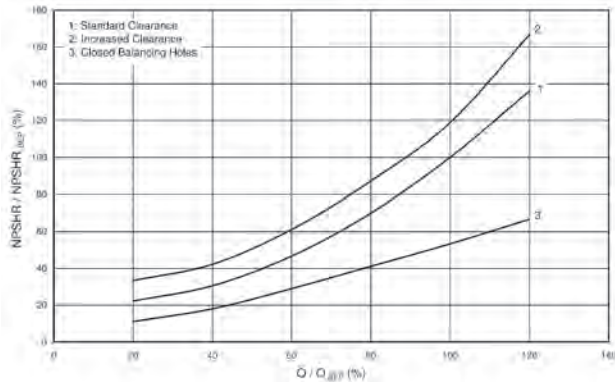

Figure 11. Influence of Balancing Holes and Wear Ring Clearance on NPSHR on a Low Specific Speed Pump.

The reason for this difference is the borehole cavitation that is caused by the leakage flow through the balancing holes. Ludwig (1992) investigated the cavitation in wear ring clearances and balancing holes. Figure 12 shows the cavitation cloud at the outlet of a balancing hole. The influence may depend on the specific speed and the design of impeller and balancing holes. Figure 11 shows also one more possible failure reason. If maintenance checks are not carried out at regular frequencies, it may be discovered that the clearances of the wear ring can become large with the result of increased NPSHR. The margin to NPSHA is reduced and can cause failures. An unfavorable design of balancing holes is presented by Figure 13. Beside improvements of the design also casting quality has an impact on the performance. Impeller castings using ceramic cores instead of sand cores are improving the accuracy of the vane geometry, and the vane surface finish and accuracy.

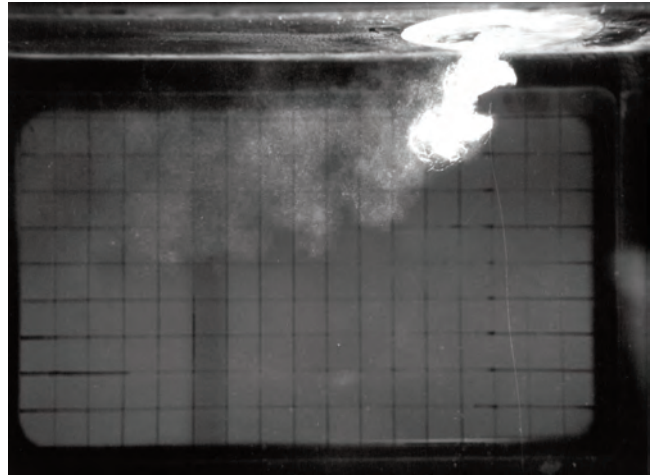

Figure 12. Cavitation Cloud at the Outlet of a Simulated Balancing Hole.



Figure 13. Unfavorable Balancing Hole Design.

It is important to note that the above-mentioned issues can reduce the NSPHR and therefore increase the  $N_{ss}$  without changing the impeller design. This is an additional hint that a general limitation of  $N_{ss}$  cannot be explained by suction recirculation caused by too large a suction eye diameter.

## EXAMPLES OF APPLICATIONS WITH HIGH NSS

### Retrofit of a Barrel Pump

In 1966 two barrel pumps with six stages were delivered to a German refinery. In 1998 the customer asked for new operating data. By using maximum impeller diameter it was possible to achieve the new flow and head. But the problem was the higher flow: NPSHA decreases and NPSHR increases. The new data and the existing suction impeller were checked. The result was that it is possible to design a new suction impeller to fulfil the new NPSH requirements. Suction eye and hub diameter remained unchanged to ensure interchangeability with the existing components. The meridional section of the impeller was changed. The leading edge was located to a different position; vane angles and the vane layout were adapted. The number of vanes was reduced from six to five. At the end of 1998 the pump was tested with the new suction impeller. All the guarantee data were fully achieved. The improvement of NPSHR can be seen in Figure 14. As a result the  $N_{ss}$  value increased from 8,670 to 11,680. Meanwhile the pump has been in successful operation for nearly 10 years. The maintenance statistics for that time period are excellent. Maintenance was only necessary once for each pump during this period:



- Pump P-4403: 2006, overhaul of the rotor with balancing
- Pump P-4403S: 2008, repair of mechanical seal

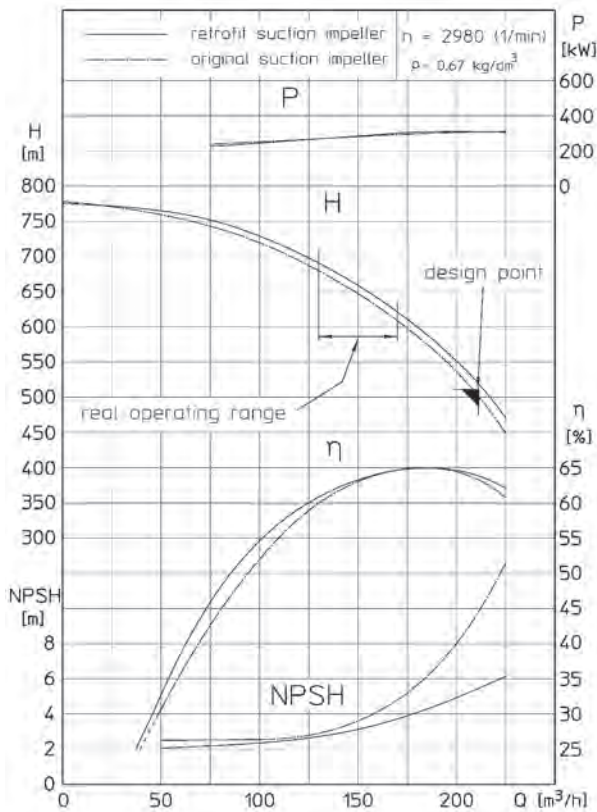

Figure 14. Retrofit of a Barrel Pump Regarding NSPHR.

The pumps are running in continuous operation. It is also worthy of mention that the flow is really less than the design flow and is varying between 130 m<sup>3</sup>/h (572 gpm) and 170 m<sup>3</sup>/h (748 gpm). Figure 15 shows the pumps at site after retrofit.



Figure 15. Barrel Pump at Site after Retrofit.

**Overhung Pump 10×12×26 with High Suction Pressure**

At an application with a suction pressure of 40 bar (580 psi) the balancing holes had to be closed to compensate the axial force caused by the high suction pressure. The speed of the pump was 995 rpm. NPSHA was only 2.2 m (7.2 ft). According to the proposal curve an NPSHR of 2.1 m (6.9 ft) was quoted. However when tested the value measured was an NPSHR of 1.6 m (5.2 ft). Therefore the suction specific speed increased from 10,908 to

15,580. This difference could be explained only by the removal of the balance holes and so the elimination of borehole cavitation. This was not the result of any hydraulic design changes to the impeller eye, vanes, or the casing. At the test bed the vibrations over the whole operating range were on a low level. The pump was installed in 1995 in a refinery in the Netherlands. No significant or frequent failures have been reported.

This size has several impellers having a Nss up to 13,500 at a speed of 1480 rpm. Worldwide this size is operating under different operating conditions (low/high suction pressure, different fluids, etc.) without problems. The installed power achieves up to 700 kW (940 hp).

**Misleading Vibration Measurement of a Vertical Pump with High Nss**

The performance of a vertical multistage pump with first stage double suction impeller was tested at the pump manufacturer’s test bed. The NPSH-test came up with a suction specific speed of 14,600. A vibration measurement was carried out at the same time. The overall vibrations (rms) at the discharge head in the direction of the piping increased from 0.09387 in/s (2.38 mm/s) at BEP to 0.193 in/s (4.9 mm/s) at minimum flow. The customer argued that the increase of the vibrations at lower flow is a result of extensive suction eye recirculation resulting from high suction specific speed design. According to Guelich (2001) partload suction recirculation creates broadband hydraulic excitation typically below the frequency of the rotational speed. Also vane passing frequency is usually increased due to this recirculation. During a vibration frequency analysis these classical indicators could not be identified. However the frequency analysis showed that the peak at one times rotational speed grew continuously from high to low flow (Figure 16). Besides unbalance, which is normally constant with flow, misalignment is in most cases the reason for high peaks at one time rotational speed. The situation at test beds cannot be compared to the site conditions. At the test bed the discharge head could be clamped only. Also the piping cannot be fixed in the same way as at site. At the test bed it is possible that piping, due to pressure forces, can move the discharge head a little bit with the result of misalignment. This can result in an already small misalignment being increased, resulting in an increase of the vibration peak at one time rotational speed as it can be seen at the frequency analysis. This shows that the vibration was caused by the misalignment, and not by suction recirculation. This was further proven by the fact that the NPSHR curve was flat at the lower flows, and showed no tendency to increase, which would be evidence of a serious onset of suction recirculation. After the installation of pump and piping was improved the peak at one time rotational speed was approximately constant from minimum to maximum flow on a normal level (< 0.042 in/s/1.07 mm/s).

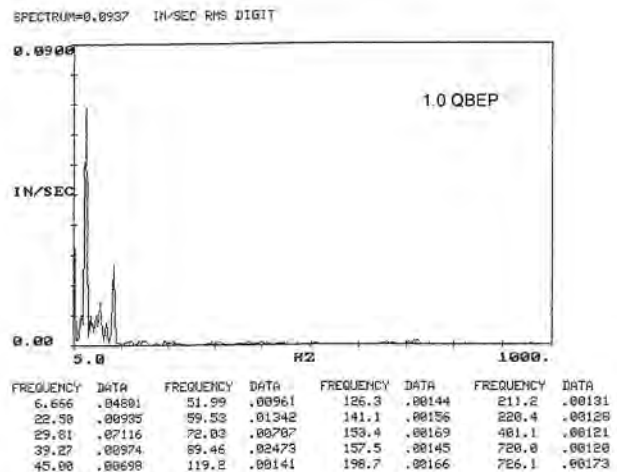

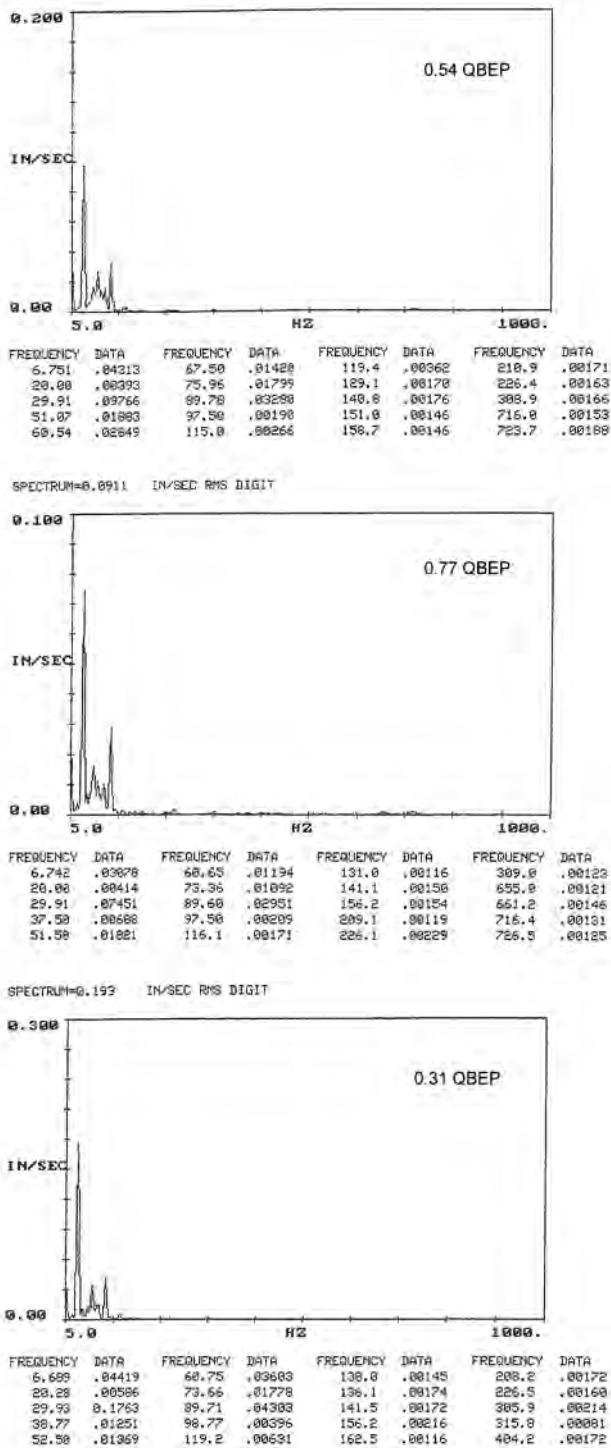

Figure 16. Vibration Analysis in the Axis of the Discharge Head Piping of a Vertical Pump.

**BETTER OPPORTUNITIES FOR SELECTING PUMPS**

The investment costs of a centrifugal pump are mainly dependent on the pump type, the lifecycle costs, the power consumption, and so the efficiency. Figure 17 shows a diagram with attainable efficiencies depending on the specific speed and the size of the pump. Using the equation of the specific speed:

$$N_s = N \cdot \frac{\sqrt{Q}}{H^{0.75}} \tag{3}$$

and from the diagram it can be realized that, e.g., a single suction pump can achieve a higher efficiency than a double suction pump with the same best efficiency point.

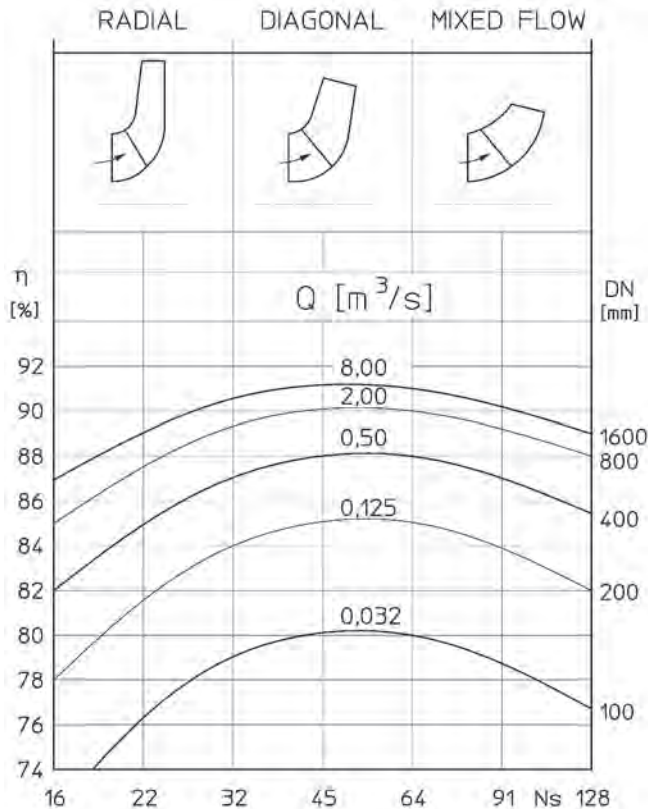

Figure 17. Maximum Attainable Efficiencies Depending on Specific Speed and Size. (Courtesy Hirschberger, 1997)

As an example for the selection of a centrifugal pump the following operating data at 50 Hz are used:

- Q = 600 m<sup>3</sup>/h (2640 gpm)
- H = 120 m (394 ft)
- NPSHA = 10 m (32.8 ft)
- Density = 0.78

Table 4 shows with this example that without a limitation of the suction specific speed a more economic pump can be selected.

Table 4. Comparison of a Pump Selection.

Type	N (rpm)	NSPHR (m)	N <sub>ss</sub>	N <sub>s</sub>	η (%)	P (kW)	Price-index
OH2	2960	8.4	12230	34	83	184	1.0
OH2	1480	4.5	10500	16	73	210	1.6
BB2	2960	6.6	10820	25	82	187	2.7

A further possibility to reduce investment costs is the application of inducers. Sometimes an overhung pump with inducer can be installed instead of a vertical pump. Figure 18 shows the NPSHR curves of an overhung pump 3×6×19 with and without inducer. Also if used in vertical pumps an inducer can reduce NPSHR and so the length of the can (Figure 19). This is especially useful at locations with difficult underground conditions, where a longer can length has a significant influence on civil works and costs involved.



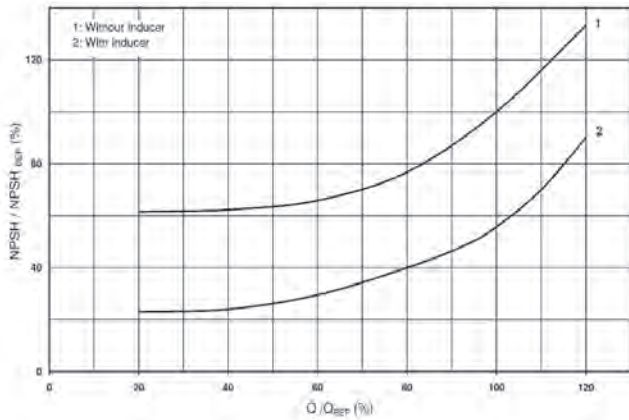

Figure 18. Comparison of NPSHR of an Overhung Pump with and without Inducer.

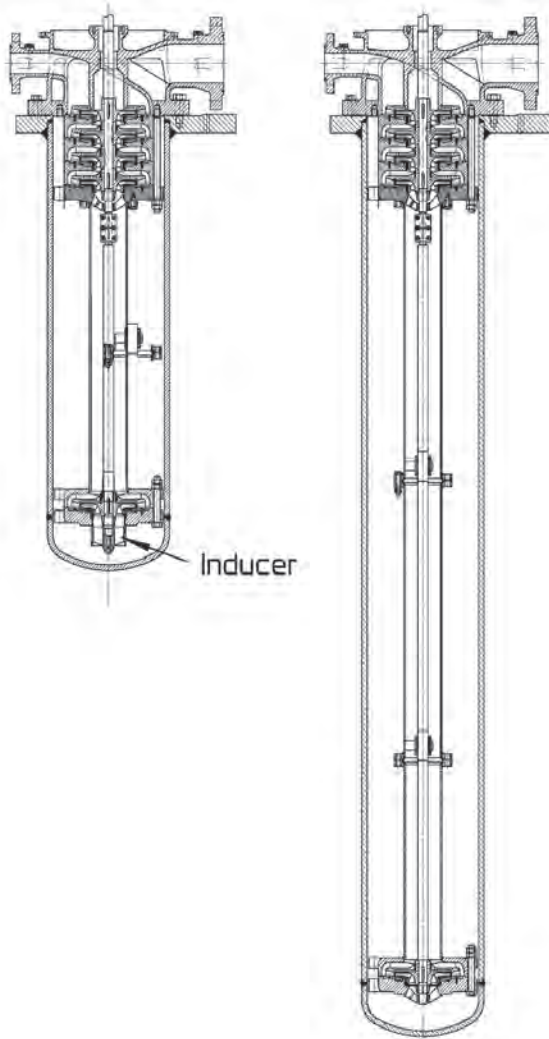

Figure 19. Reduction of Can Length Using an Inducer.

CONCLUSIONS

Hallam (1982) found a serious lack in the reliability of centrifugal pumps designed in the 1960s and recommended a limitation of the suction specific speed. He argued that high Nss, which means low NPSHR, can only be achieved by using very large suction eye diameters, and also that large suction eye diameters are generating excessive suction recirculation and this was the reason for a higher number of failures. However, as explained in this paper, recirculation

depends not only on the suction eye diameter but on several additional parameters. Investigations on high and medium Nss impellers by Stoffel and Jaeger (1996) have shown no significant difference of the dynamic quantities like vibrations or shaft deflection. With improved designs of different pump components the NPSHR can be reduced, and a better cavitation performance can be achieved with a high level of pump reliability.

To limit the suction specific speed is an oversimplification that hides the real causes of the early pump failures, which in reality can be attributed to a variety of other reasons. Without the suction specific speed limitation there are new opportunities to select more economical centrifugal pumps.

NOMENCLATURE

- BB2 = Between bearing pump, according to API 610 (2004)
- BEP = Best efficiency point
- De = Impeller eye diameter (in)
- H = Head
- N = Rotational speed (rpm)
- NPSHR = Net positive suction head required based on 3 percent head drop
- NPSHA = Net positive suction head available
- Ns = Specific speed
- Nss = Suction specific speed
- OD = Outer diameter of the impeller
- OH2 = Overhung pump, according to API 610 (2004)
- P = Power
- q = Relative flow rate  $Q/Q_{BEP}$
- Q = Flow
- SE = Suction energy
- $\eta$  = Efficiency
- $\rho$  = Specific gravity

Subscripts

- BEP = Best efficiency point
- Rec = Recirculation

REFERENCES

ANSI/HI 9.6.1, 1998, "Centrifugal and Vertical Pumps," Guideline for NPSH Margin, Hydraulic Institute, Parsippany, New Jersey, (Guideline has been withdrawn).

API Standard 610, 2004, "Centrifugal Pumps for Petroleum, Petrochemical and Natural Gas Industry," Tenth Edition, American Petroleum Institute, Washington, D.C.

Bruegelmanns, F. A. E. and Sen, M., 1987, "Prerotation and Fluid Recirculation in the Suction Pipe of Centrifugal Pumps," *Revue M Tijdschrift*, 31, (3/4), pp. 115-126.

Bunjes, J. H. and op de Woerd, J. G. H., 1984, "Erosion Free Operation of Cavitating Pump," *IMEchE C28/84*, pp. 1-12.

Budris, A. R., 1993, "The Shortcomings of Using Pump Suction Specific Speed Alone to Avoid Suction Recirculation Problems," *Proceedings of the Tenth International Pump Users Symposium*, Turbomachinery Laboratory, Texas A&M University, College Station, Texas, pp. 91-95.

Fraser W. H., 1982, "Recirculation in Centrifugal Pumps," *World Pumps*, pp. 227-235.

Guelich, J. F., 2001, "Selection Criteria for Suction Impeller of Centrifugal Pumps," Part One to Three, *World Pumps*, January, March and April.

Guelich, J. F., 2004, *Kreiselpumpen. Ein Handbuch für Entwicklung, Anlagenplanung und Betrieb*, 2. Auflage, ISBN 3-540-40587-9.

Guelich, J. F. and Egger, R., March 1992, "Part Load Flow and Hydraulic Stability of Centrifugal Pumps," EPRI Report TR-100219.

- Hallam, J. L., 1982, "Centrifugal Pumps: Which Suction Specific Speed Is Acceptable?" *Journal of Hydrocarbon Processing*, pp. 195-197.
- Hirschberger, M., 1997, "Securing High Energy Economy by the Prevention of Designing Excessively Sized Pump Units," *Pumps and Compressors*, pp. 27-33.
- Ludwig, G., 1992, "Experimentelle Untersuchungen zur Kavitation am saugseitigen Dichtspalt von Kreiselpumpen sowie zu sekundären Auswirkungen des Spaltstromes," Ph.D. Thesis, University of Technology Darmstadt.
- Roth, M., 2006, "Experimentelle und numerische Untersuchung zum Einfluss von Einbaubedingungen auf das Betriebs- und Kavitationsverhalten von Kreiselpumpen," Ph.D. Thesis, University of Technology Darmstadt.
- Sen, M., 1980, "Study of Inlet Flow of Centrifugal Pumps at Partial Flow Rates," Ph.D. Thesis, von Karman Institute, Brussels.
- Stoffel, B. and Jaeger, R., 1996, "Experimental Investigations in Respect to the Relevance of Suction Specific Speed for the Performance and Reliability of Centrifugal Pumps," *Proceedings of the Thirteenth International Pump Users Symposium*, Turbomachinery Laboratory, Texas A&M University, College Station, Texas, pp. 3-12.