

Offroad Tires for Quarry Applications

Presented By: Jim Van Ordse



QUARRY
ACADEMY

LIGHTEN UP!

Tire Construction

Radial OTR
Tire

Bias OTR
Tire

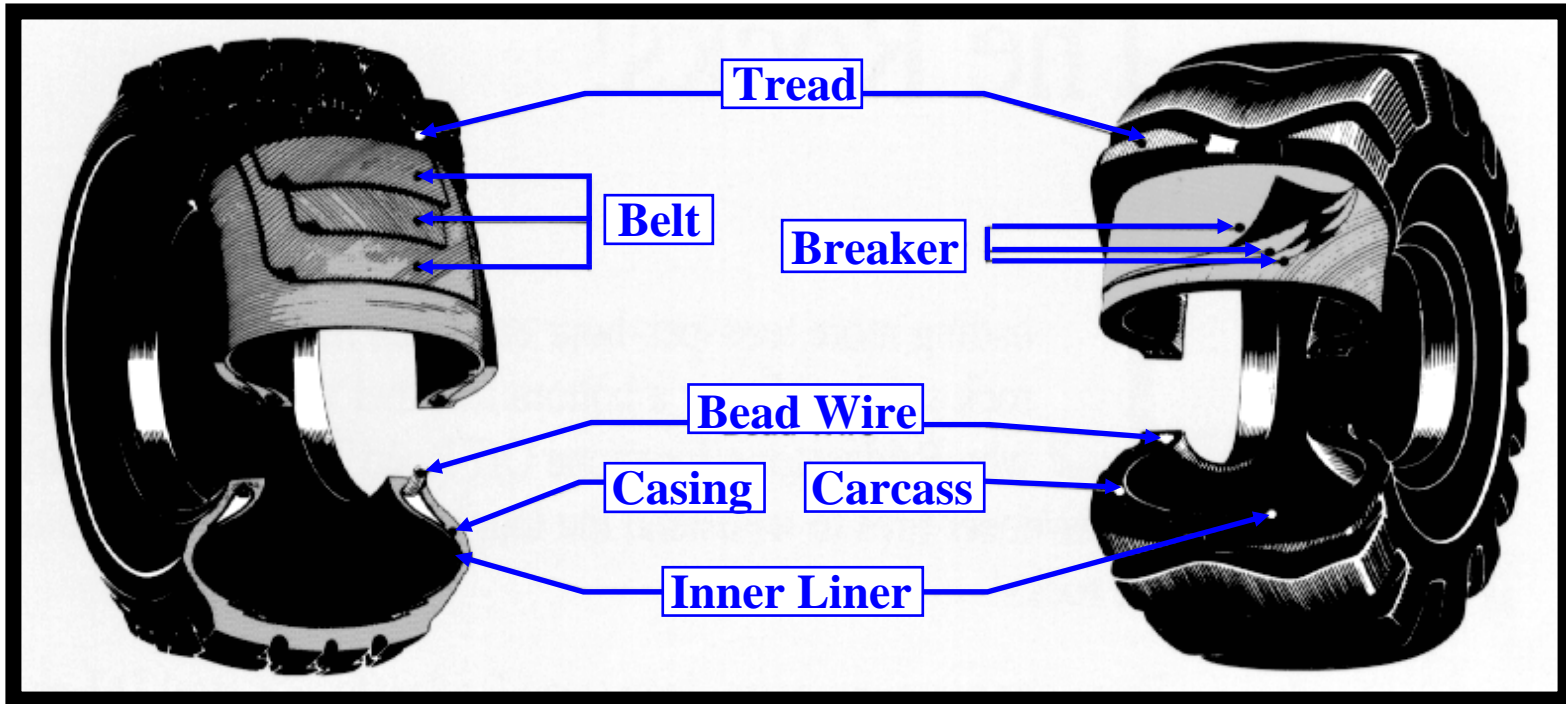

BELT PACKAGE (OUTER)

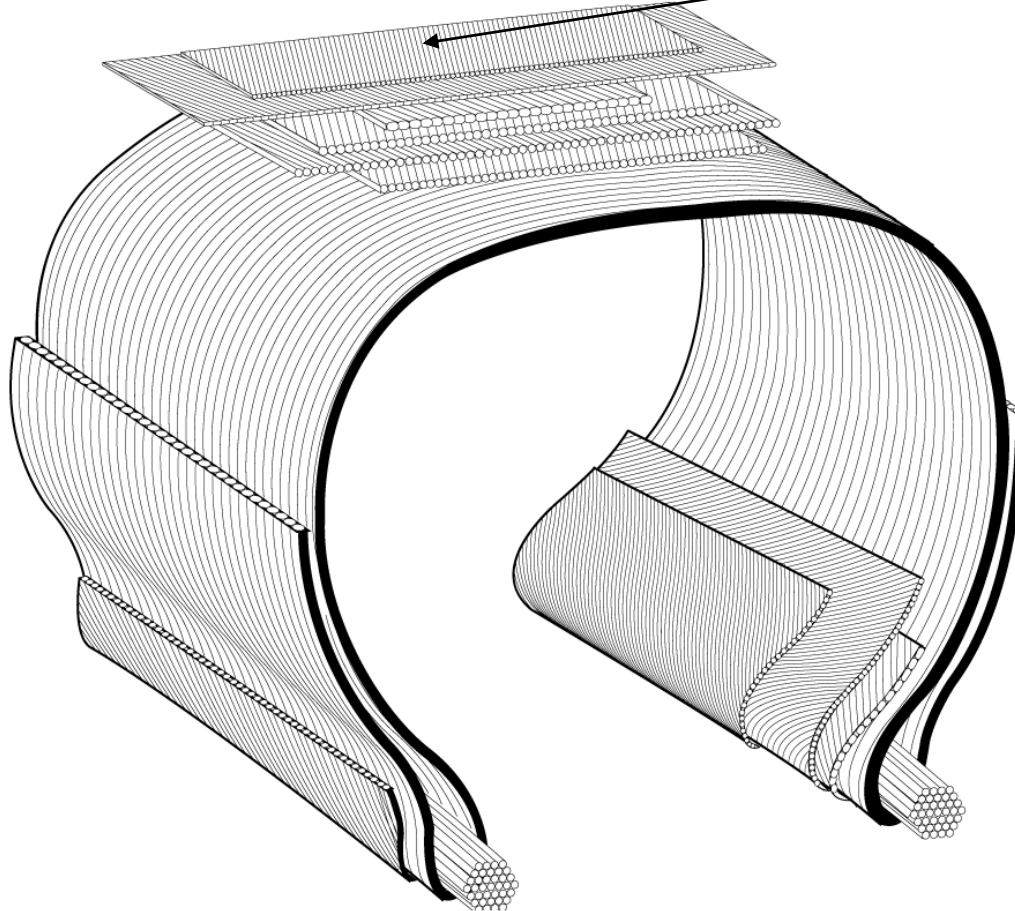

RUBBER COATED
STEEL
- 2 LAYERS
BELTS TO AVOID
CUT &
SEPARATION
HIGH ELONGATION
BELT

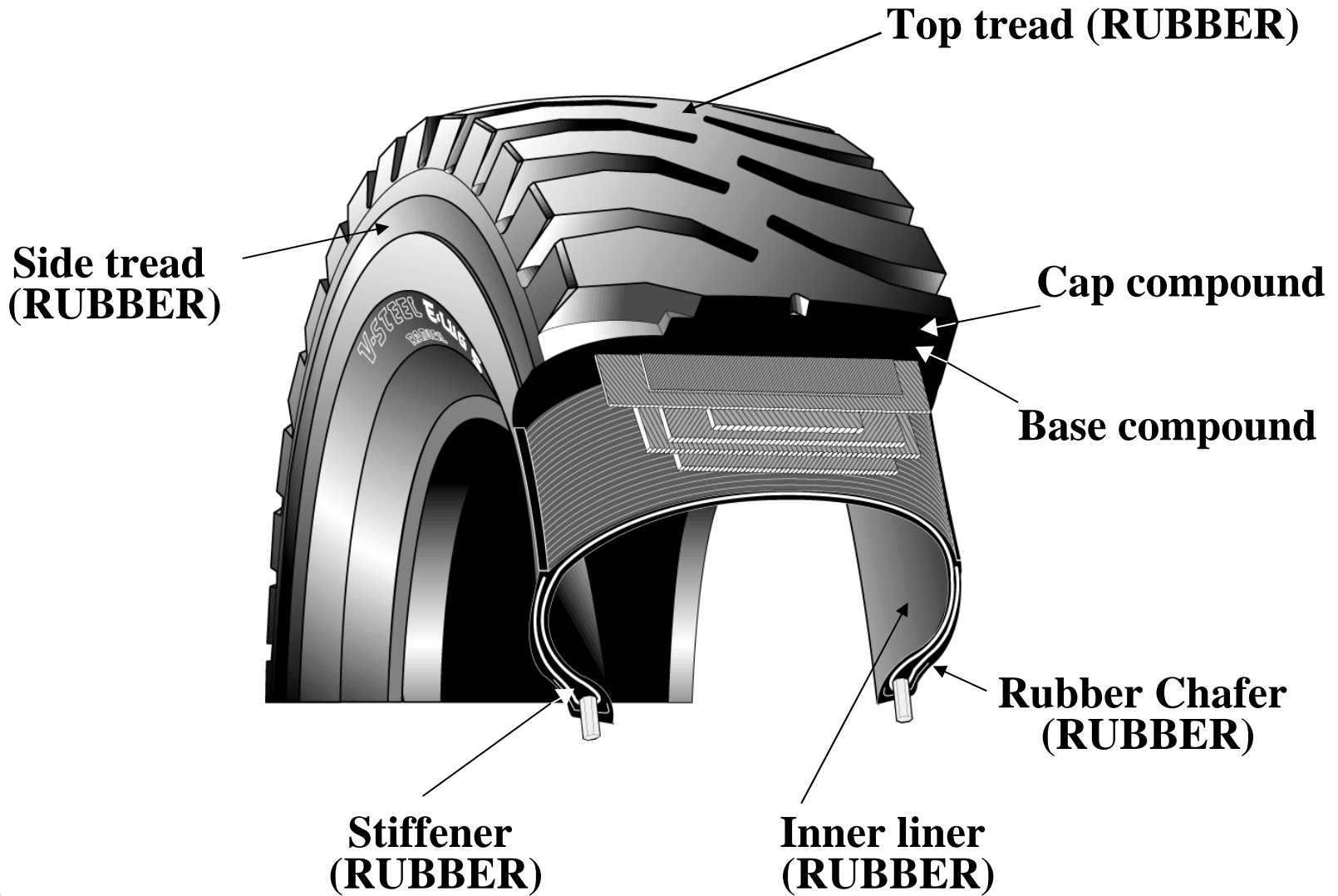

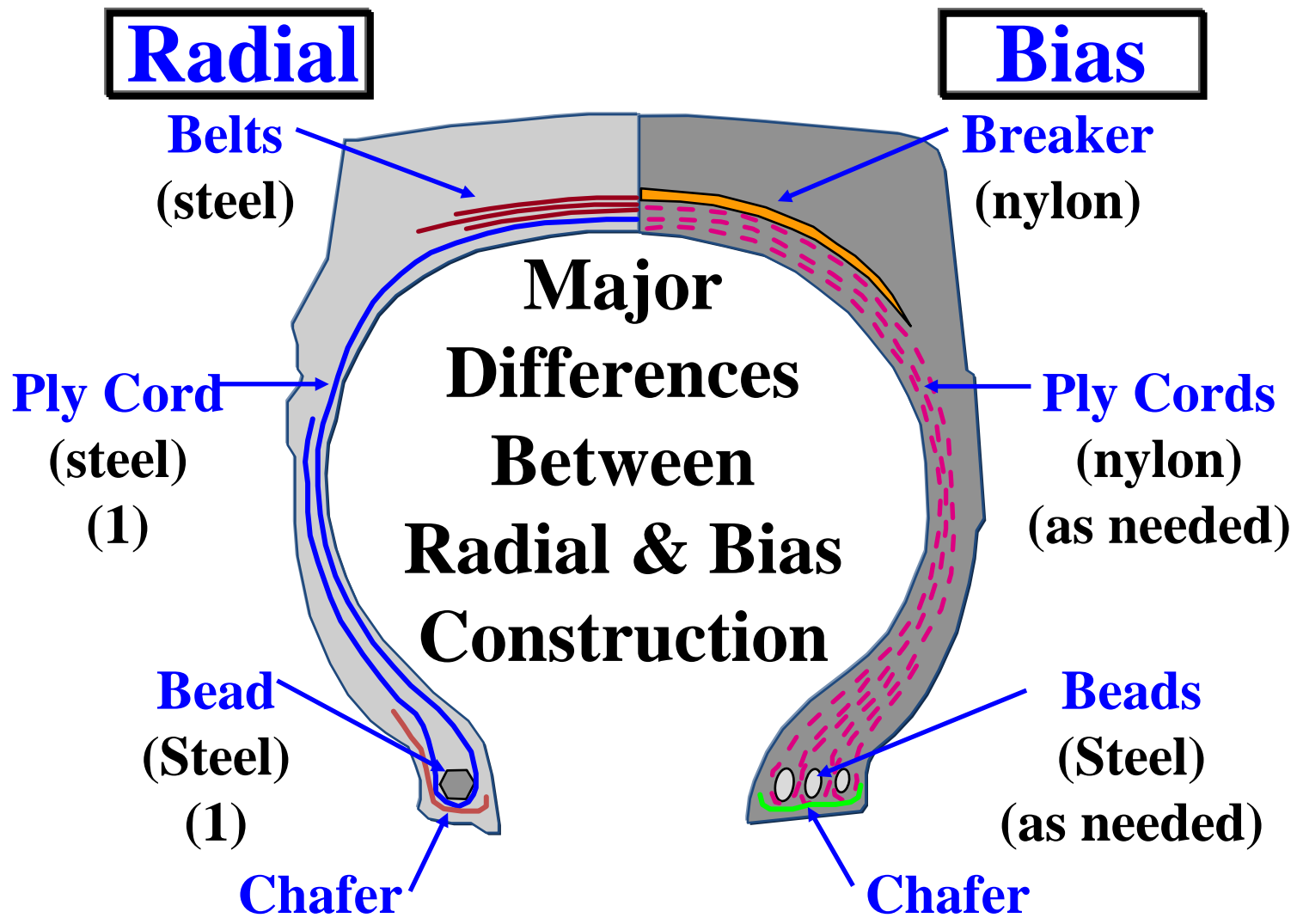

Strengths of Radial / Bias Tires

	Radial	Bias
Tread Life	<input type="checkbox"/>	
Heat Resistance	<input type="checkbox"/>	
Cut Resistance	<input type="checkbox"/>	
Sidewall Cut Resistance	<input type="checkbox"/>	<input type="checkbox"/>
Traction	<input type="checkbox"/>	
Flotation	<input type="checkbox"/>	
Stability		<input type="checkbox"/>
Repairability	<input type="checkbox"/>	
Fuel Economy	<input type="checkbox"/>	
Rim Component Life	<input type="checkbox"/>	<input type="checkbox"/>
Size Availability	<input type="checkbox"/>	<input type="checkbox"/>

Advantages of Radial Tires

Steel Belts
(stronger resistance)

Single Steel Ply Cord
(greater flexibility)

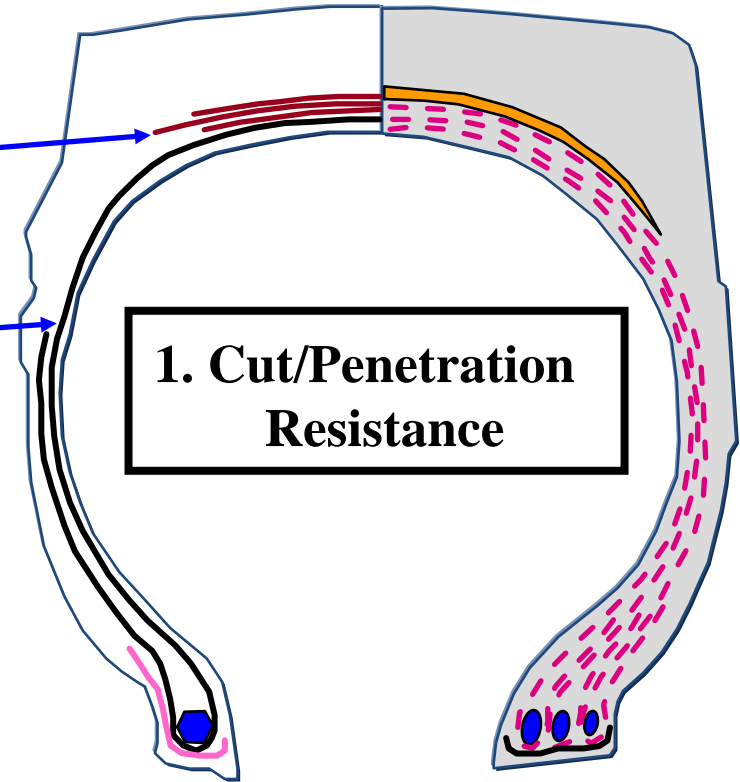

Radial Tires are about 80% more resistant to cut/penetrations in the tread area. Also, Radial tires suffer less damage from cutting even during severe operations.

Advantages of Radial Tires

Radial

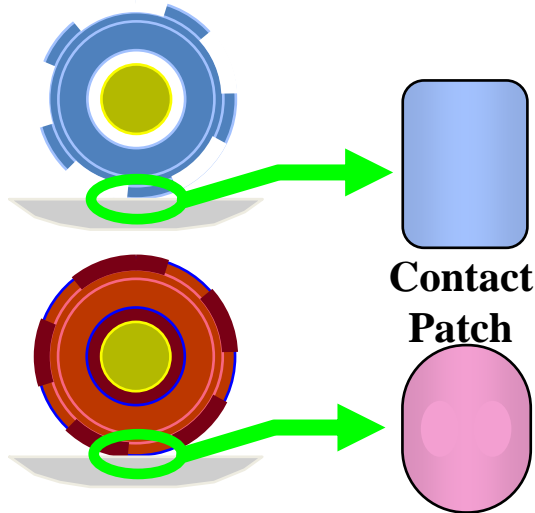

Bias

2. Better Traction, Flotation, and Lower Fuel Consumption

Radial Tires have stiffer tread and distribute weight in a more uniform manner. This gives a steady and consistent contact patch which promotes greater traction and flotation. Also, rolling resistance is decreased which results in better fuel efficiency.

13% Better Traction	23% Less Roll Resistance	7% Better Fuel Economy
--------------------------------------	---	---

Advantages of Radial Tires

3. Greater Wear Resistance, Speed Durability, and Loading Capacity

Heat increases in a tire when loaded & when in motion. Excessive heat build-up is a major cause of tire damage. Due to a rigid tread, more “simple” construction, and the absence of many cloth plies, radials are much more effective at reducing heat.



Tread rigidity & strong support from steel belts restrains tread movement. The triangular geometry of the steel belts also provides greater resistance to deformation than the pantographic geometry of bias tires. The combination of these conditions promote better wear, load capacity, and speed.

Tire Nomenclature

Basic Tire Components

The sidewall nomenclature of an off road tire provides a wealth of information about a specific tire:

- Tire size
 - Physical dimensions
- Construction
 - Radial ply
 - Bias ply
- Strength
 - Load capacity
 - Inflation pressure
- Pattern type
 - Pattern class
 - Manufacturer description
- Application
 - Compounds

TRA Classifications

Allow for a **common** language and designation system for **all** brands and manufacturers.

These classifications are based on **Application Type** and provide Comparison Standards based on **Tread Depth**.

Ply Rating / Star Rating

The word “Ply” originated when Cotton was used for casing cords. For example, a 1200-24 needed 14 cotton plies to carry 6,600 lbs. As new materials were introduced, the industry found that 8 actual nylon plies could do the same job as 14 cotton plies, thus the term “Ply Rating” was born.

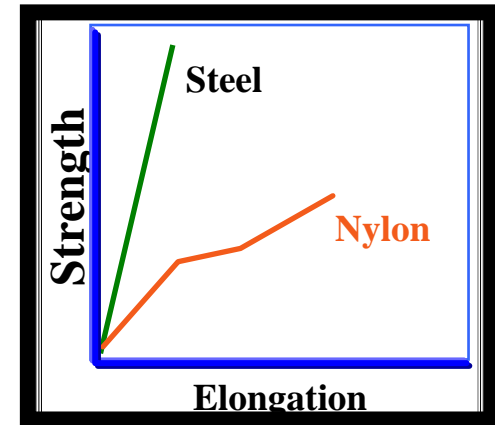

With the development of the Radial, only 1 Steel ply cord was used - regardless of the load to be carried. Since this differed so much from the bias methodology, the TRA instituted the “Star Rating”. This system uses 1, 2, or 3 stars (*, **, ***) to determine the load range of radial tires.

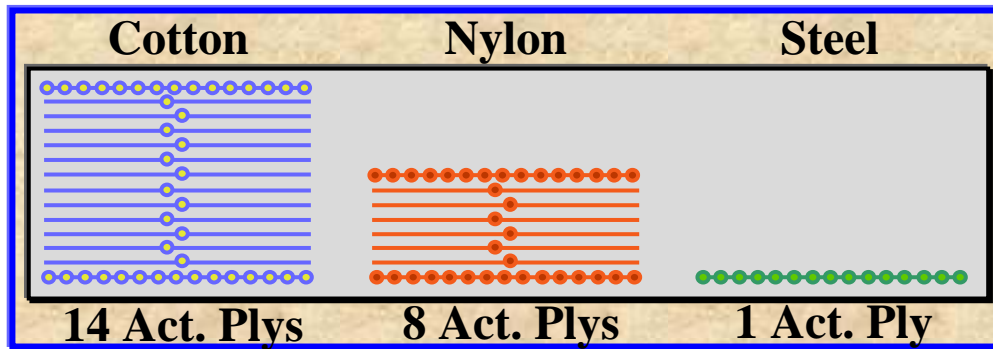

Consult your tire manufacturer’s Data Book or TRA’s guidelines for load and inflation parameters of a given OTR tire.

Conversion Table:

Service	Tire Size	Star Rating	Corresponding Ply Rating
Grader	14.00R24	★	up to 16
	16.00R24	★	up to 16
	17.5R25	★	up to 16
Earthmover	12.00R24	★★★	up to 24
	14.00R24	★★★	up to 32
	14.00R25	★★★	up to 32
	16.00R25	★★	up to 36
	18.00R25	★	up to 24
		★★	up to 36
	18.00R33	★★	up to 40
	21.00R33	★★	up to 36
	21.00R35	★★	up to 44
	24.00R35	★★	up to 48
	24.00R49	★★	up to 48
	27.00R49	★★	up to 54
	30.00R51	★★	up to 58
	33.00R51	★★	up to 64
	36.00R51	★★	up to 66
	40.00R57	★★	up to 74
	17.5R25	★	up to 16
	20.5R25	★	up to 24
		★★	up to 28
	25/65R25	★★	up to 32
23.5R25	★	up to 24	
	★★	up to 32	

Star Rating to Ply Rating

Service	Tire Size	Star Rating	Corresponding Ply Rating
Earthmover	26.5R25	★★	up to 32
	29.5R25	★★	up to 34
	29.5R29	★★	up to 40
	33.25R29	★★	up to 44
	33.5R33	★★	up to 44
	37.5R33	★★	up to 48
	33.25R35	★★	up to 44
	37.25R35	★★	up to 48
	37.5R39	★★	up to 52
	40.5/75R39	★★	up to 54
Loader	15.5R25	★	up to 16
	17.5R25	★	up to 16
	20.5R25	★	up to 24
		★★	up to 28
	23.5R25	★	up to 24
		★★	up to 32
	26.5R25	★	up to 24
		★★	up to 36
	29.5R25	★	up to 28
		★★	up to 34
	29.5R29	★	up to 34
	35/65R33	★	up to 36
	45/65R45	★	up to 50

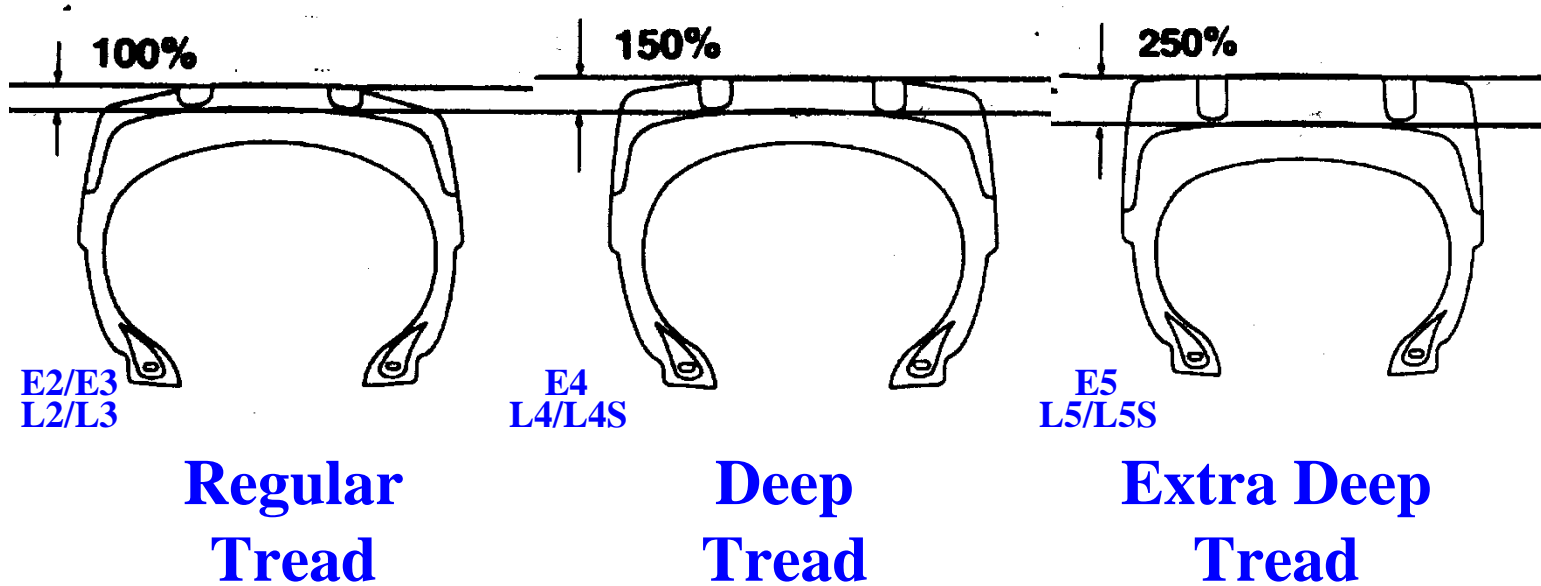

Tread Depth Designation is based on an index, not a specific measurement. This means that an E3 tread depth may differ between manufacturers, but an E4 should be 150% of each manufacturer's E3.

Reading Tire Dimensional Information

Basic Tire Definitions

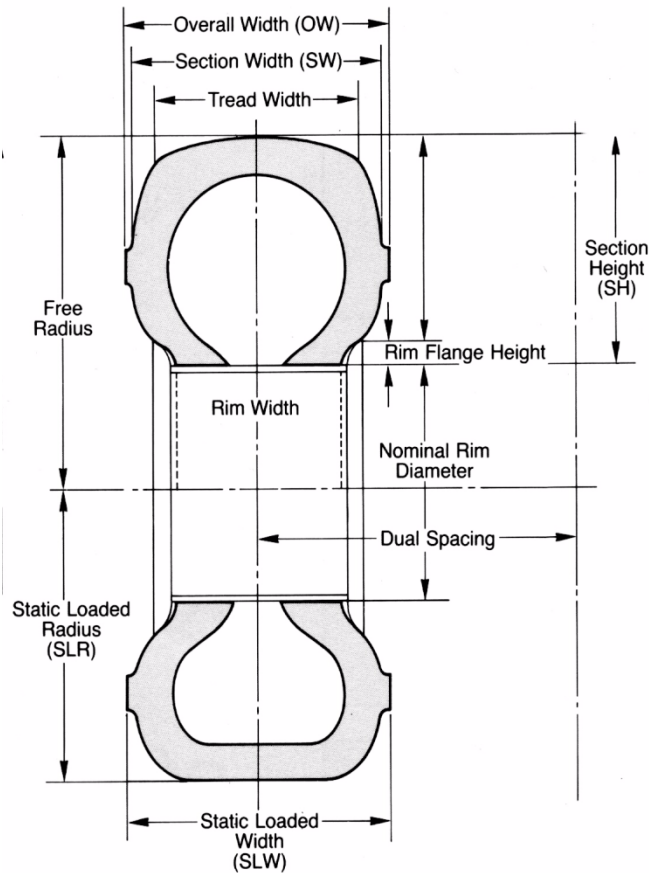

Overall Diameter (OD):

“OD” is twice the section height of a new tire, plus the nominal rim diameter, including inflation growth.

Overall Width (OW):

“OW” is the width of a new inflated tire, including all protective side ribs, bars, or decorations.

Basic Tire Definitions

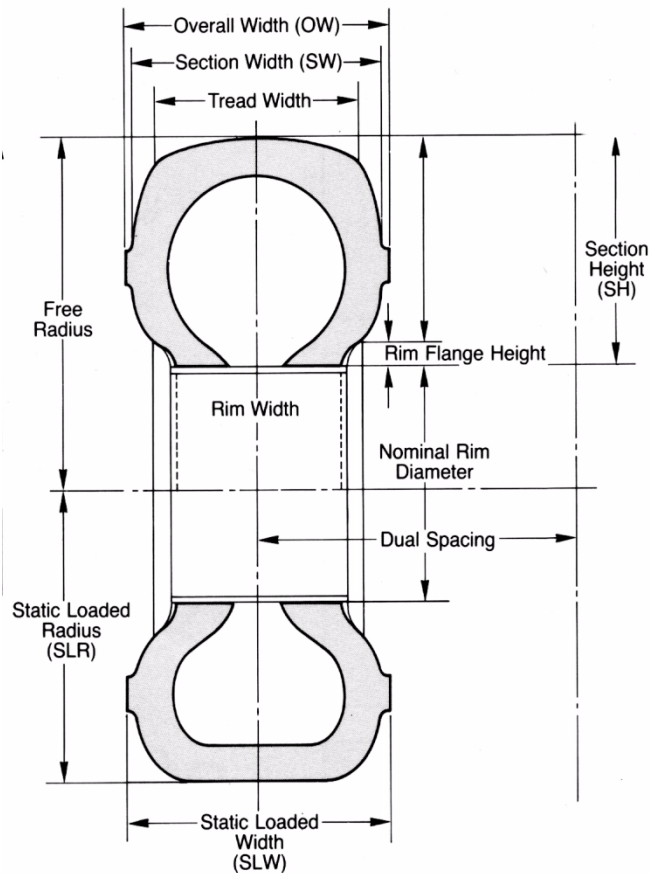

Section Width (SW):

“SW” is the width of a new inflated tire including normal sidewalls, but not including protective side ribs, bars or decorations.

Static Loaded Radius (SLR):

“SLR” is the shortest distance from the axle center to the contact surface of a tire.

Basic Tire Definitions

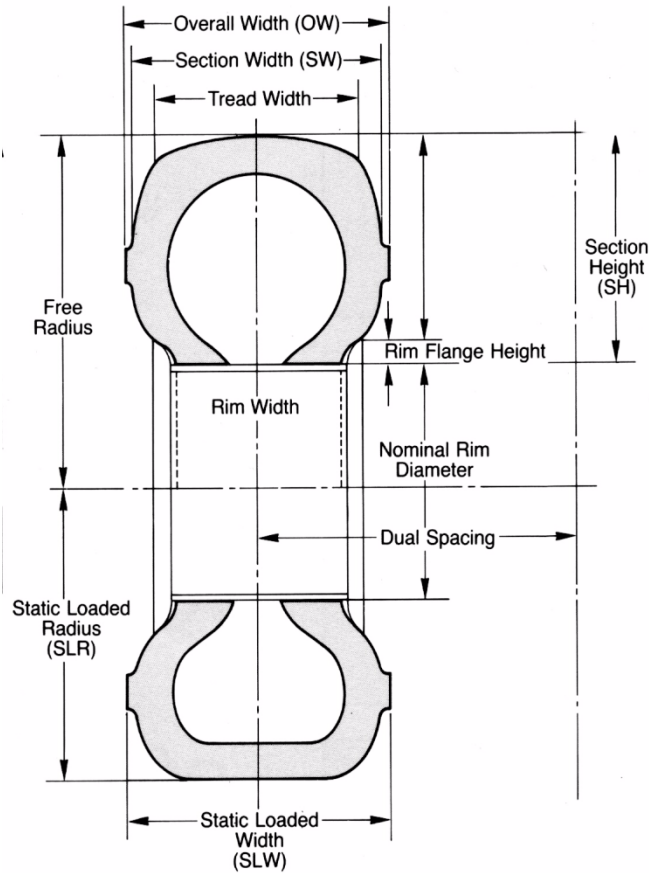

Recommended Rim Width and Flange Height:

The recommended minimum width of a rim measured from flange to flange. The flange height is the minimum height of the vertical collars of the rim which retain the outer edges of the tire.

Reading Tire Load and Inflation Tables

Reading Tire Inflation Pressure Charts

1. Find the appropriate chart for the machine type:

<u>TRA Class</u>	<u>Maximum Speed</u> (mph)	<u>Maximum Distance</u> (miles)
E = Earthmover	30 mph	2.5 miles one-way
L = Loader/Dozer	5 mph	250 ft. one-way
G = Grader	25 mph	Unlimited
HWY = Highway	55 mph	Unlimited
IND = Industrial	5 mph	Various

Reading Tire Inflation Pressure Charts

- 2. Choose the table for the appropriate construction (radial or bias).**
- 3. Locate the size and ply or star rating.**
- 4. Read the rated tire load and inflation pressure**

Off-The-Road Tire Selection

Factors Influencing Proper Tire Selection

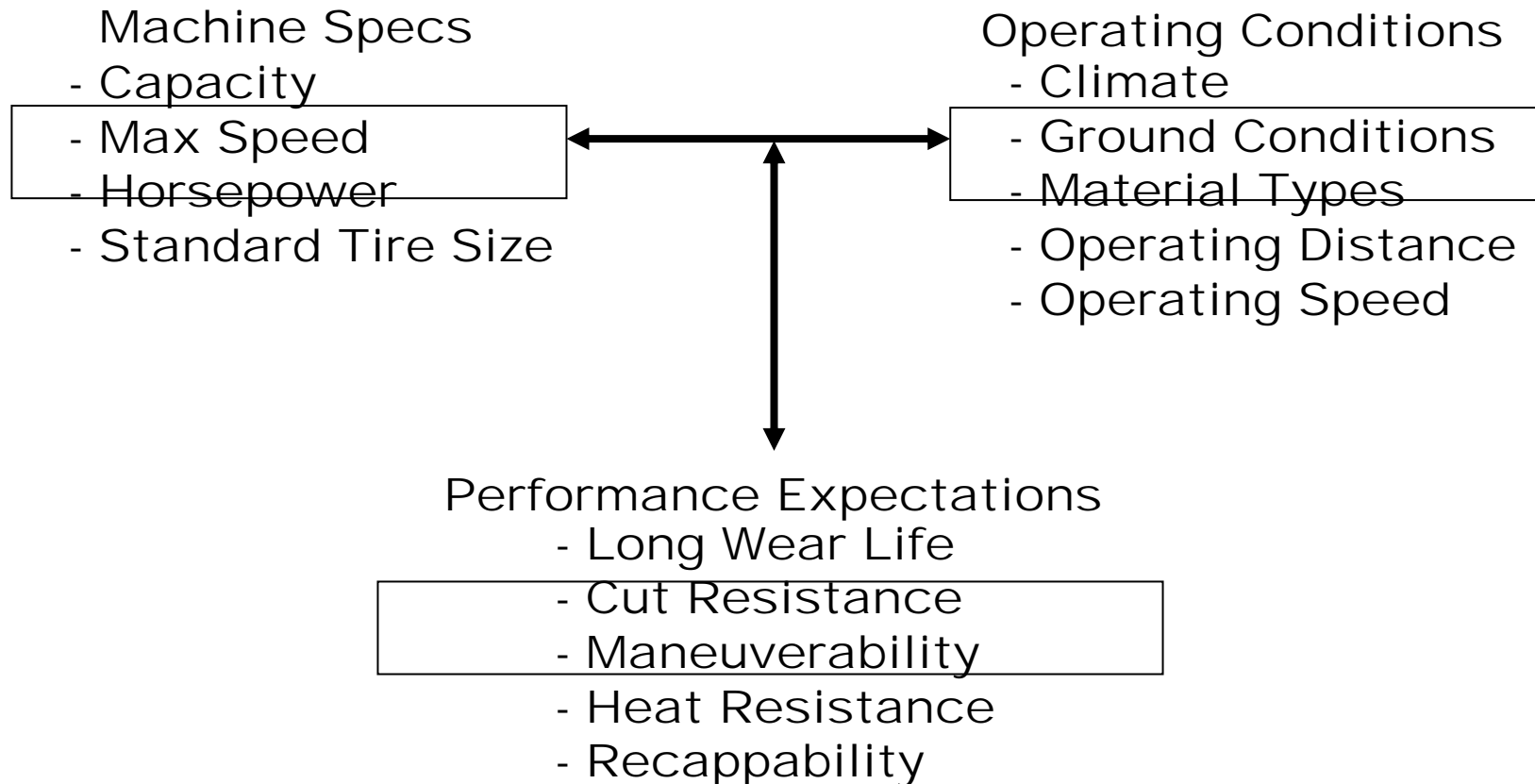

Loader Tires - Typical Uses

1. Truck Loading

- High cut damage risk
 - Deep tread tires best to minimize cut damage
 - Special compounds for maximum cut resistance
- High load factors
 - Use of high ply ratings increase capacity and durability of tire casing

Loader Tires - Typical Uses

2. Load and carry operation

- Speeds up to 15 mph
 - Distances from 300 ft to 1000 ft
 - High heat generation
 - Use L4 depth tires where possible
 - Use load and carry compound to reduce heat
 - Radial tires have higher TMPH

Loader Tires - Typical Uses

2. Load and carry operation

- High tire loads
 - Tire load capacity decreases with speed
 - 5 mph = 100% load capacity
 - 15 mph = 80% load capacity

High ply rated tires may be required to carry loads

Special Applications

Load & Carry

As previously mentioned, loaders present many challenges to OTR Tires. In a load & carry operation, certain limits should be observed:

Tread Class	Haul Distance (one way)	Maximum Speed	Load
L-2, L-3, L-3S	2000 ft	15 mph	Rated - 20%
L-4, L-4S	800 ft	15 mph	Rated - 20%
L-5, L-5S	250 ft	5 mph	Rated - 20%

Loader Tires

Inflation pressure key for successful loader tire use:

- Due to high deflection during bucket breakout in the pile, front tires should have additional pressure added:
 - Small tires: (less than 23.5-25): **+5 psi**
 - Medium tires (26.5-25 to 29.5-29): **+10 psi**
 - Large tires (greater than 29.5-29): **+15 psi**

This applies to both radial and bias ply tires

Trucks - Tire Selection Criteria

- **Tire construction type**
- **Tire tread patterns**
- **Tire tread compound types**
- **Tire ton-mile-per-hour (TMPH)**

Trucks - Tire Selection Criteria

2. Tire compound and Ton-mile per hour (TMPH):

- The capability of a tire to operate within a given set of operating conditions is expressed by Ton-mile-per-hour (TMPH) and is calculated by the formula:

$$\text{TMPH} = \text{MEAN TIRE LOAD} \times \text{AVERAGE WORK SPEED}$$

2. Tire compound and Ton-mile per hour (TMPH):

- Factors influencing TMPH
 - Truck tare and gross weights
 - Haul cycle length
 - Haul conditions
 - Grades
 - Design of curves
 - Tire compound and tread pattern selection

Heat Resistance/TKPH

Heat Resistance/TKPH

Earthmoving and mining equipment tires have become increasingly important with the development of more high efficiency equipment.

The primary task of these heavy-duty tires is to move heavy loads faster and over longer distances. This heavy hauling inevitably causes heat build-up in the tires.

As tires have limited resistance to heat, deterioration of the tire may begin at an early stage of operation.

Accordingly, it is necessary when selecting tires, to determine the amount of work which will keep the tire within a safe range to avoid over heating when the machine is operated under given conditions.

Formula for Calculation of Operating TKPH

$$\text{TKPH (TMPH)} = \left[\frac{\text{Image of two trucks}}{2} \right] \times \left[\text{Image of a truck at a pile of material} \right]$$

IN A SHIFT

$$\text{TKPH (TMPH)} = \text{Mean Tire-Load} \times \text{Ave. Work-Shift Speed}$$

$$\text{MEAN TIRE-LOAD} = \frac{\text{Tire Load: EMPTY} + \text{Tire Load: LOADED}}{2}$$

$$\text{AVERAGE WORK-SHIFT SPEED} = \frac{\text{Round-Trip Distance} \times \text{Number of Cycles/shift}}{\text{Total Hours of Operation/shift}}$$

$$1\text{TKPH} = 1.46\text{ TMPH}$$

Revising the TKPH due to change in maximum ambient temperature:

a. Bias Tire

Revised TKPH rating = TKPH \times [1- α \times (Ambient Temperature $^{\circ}\text{C}$ -38 $^{\circ}\text{C}$)]

Below 27.00(33.5) inches: $\alpha = \underline{0.006}$

Above 30.00(37.25) inches: $\alpha = 0.005$

b. Radial Tire

Revised TKPH rating = TKPH \times [1- α \times (Ambient Temperature $^{\circ}\text{C}$ -38 $^{\circ}\text{C}$)]

Below 27.00(33.5) inches: $\alpha = 0.012$

Above 30.00(37.25) inches: $\alpha = 0.010$

Additional Notes:

Consult your Tire Representative for additional help with TKPH calculation.

Tire Compounds have differing TKPH values:

Cut Resistant TKPH < Standard TKPH < Heat Resistant TKPH
but..

Cut Resistant wear > Standard wear > Heat Resistant wear

Off-The-Road Tire Maintenance

Why is Proper Tire Maintenance Important?

- **Tires are one of the highest equipment operating costs**
- **The correct tire can maximize machine performance, increasing productivity**
 - **Go where you want...**
 - **When you want to go...**
 - **At the speed you want to go...**

Tire Maintenance and Care

Simple ways to get the most from your tires

- **Site maintenance procedures**
 - Haul maintenance
 - Load/Dump area maintenance
- **Proper tire inflation pressure maintenance**
- **Proper mounting**

Haul Road Design and Maintenance Factors

- Surface Preparation and Maintenance
 - Is the Road Surface Smooth and Clean?
- Road Width and Crown
 - Is the Haul Road Wide Enough to Permit Trucks to Pass Safely?
 - Does the Haul Road Drain Water Properly?

Haul Road Design and Maintenance Factors

- **Solid Underbase Material**
- **Proper Surface Materials and Compression**
 - **Hard Packed Material that Provides Adequate Traction with Minimal Abrasive Qualities**
 - **Compressed to Avoid Rutting/Grooving**
- **Continual Hazard Removal/Grading**
 - **Rock/Debris Removal**
 - **Grading to Maintain Surface Conditions**

Haul Road Design and Maintenance Factors

- **Loading and Dump Area Requirements:**
 - Minimize Grade Out of Loading/Dump Areas
 - Reduces Tire Spin
 - Increased Productivity due to Faster Acceleration
 - Wide Turning Area
 - Reduces Side Loading of Tires
 - Continuous Hazard Removal/Maintenance
 - Dozer Operation to Clear Loading Areas
 - Grader Operation for Entry/Exit Areas

Haul Road Design and Maintenance Factors

- **Super Elevation**
 - Eliminates High Side Forces On Tires
 - Extends Casing Life of Tires
 - Reduces Scuffing and Tread Wear On Tires
 - Allows for More Consistent Speed During Turns
 - Less Braking Needed for Turns
 - Faster Cycle Times
 - Reduces Spillage on Haul Road
 - Reduced Cut Damage to Tires
 - Speed, Curve Radius and Super Elevation are Related

Tire Inflation Pressure Maintenance

Tire Inflation Pressure Rules

- In a pneumatic tire, the contained air pressure carries the load, not the tire casing
- To operate efficiently, a tire should be inflated to a pressure that matches the load carried.
- Incorrect tire inflation pressure will generate heat in the tire, reducing tire life.

Tire Inflation Pressure Maintenance

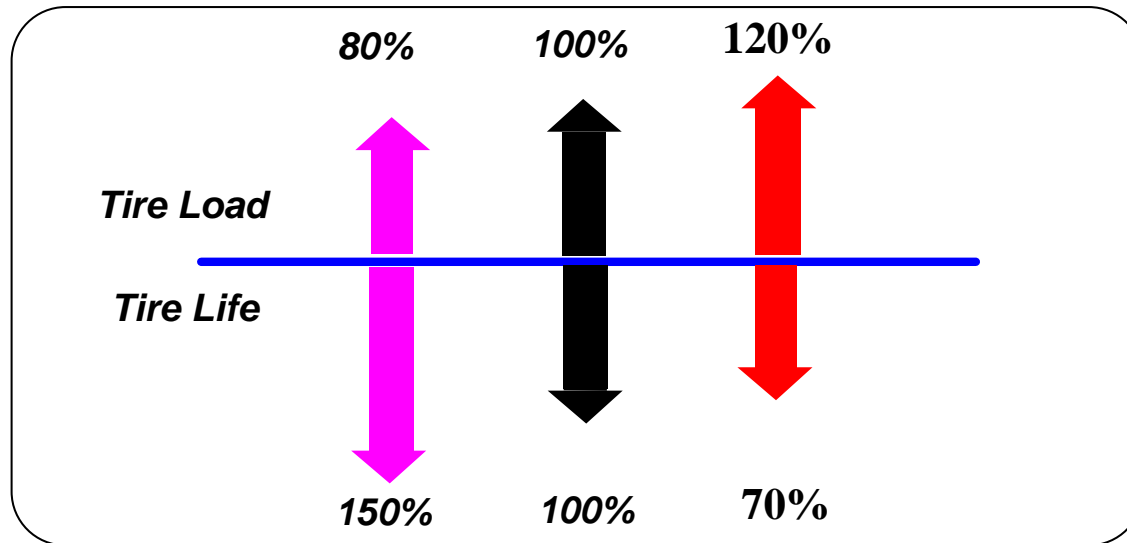

Using a tire above the rated load capacity or underinflated can significantly reduce tire life.

Inflation Pressure Maintenance

Inflation Monitoring Programs Should Be Developed To Maximize Tire Performance:

Suggestions:

- 1. Put Tire Gauges in equipment and monitor tire pressure during daily inspections. Record values and report any unusual conditions.**
- 2. Minimum weekly inspection program during routine maintenance or fuel stops.**

Proper Mounting

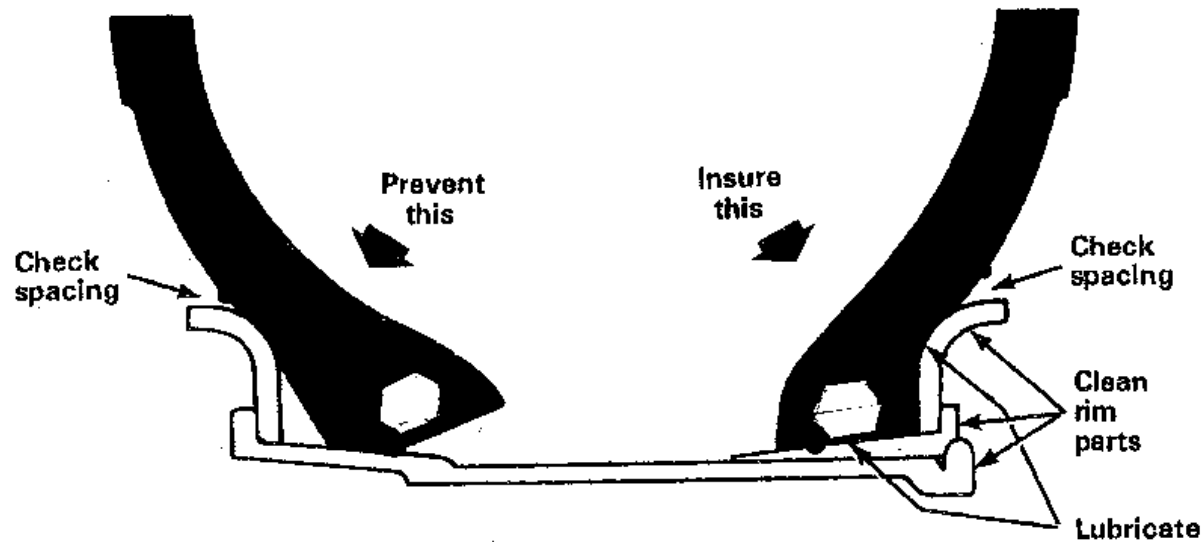

1. Clean rim parts.
2. Lubricate beads & rim.
3. Check spacing between rim flange and centering rib.

Factors Affecting Tire Performance

- **Wheel Position**
- **Average Cycle Speed**
- **Load**
- **Material Type**
- **Tire Pressure**
- **Maintenance and Driver Practices**

Factors Affecting Tire Performance

Factor No. 2: Avg. Cycle Speed Effect on Tire Life

8 mph maximum	Par
12 mph maximum	90%
15 mph maximum	75%
18 mph maximum	60%

Factors Affecting Tire Performance

For example, if a tire under ideal operating conditions, would deliver 7,500 hours of service, resulting tire hours under conditions shown below would result in 2,635 actual hours of service

<u>Factor</u>	<u>Effect on Tire Life</u>
1. Drive Wheel Position	60%
2. 12 mph Cycle Speed	90%
3. 10% Overload	85%
4. Some Rock	90%
5. Rated Inflation	100%
6. Average Maintenance & Driver Practices	85%

Estimated Life based on above factors equals 2,635 hours

www.quarryacademy.com



**QUARRY
ACADEMY**

LIGHTEN UP!